



ISO9001: 2008 Quality Management System Authentication

ENA100 Seies

Ver.1.0

0.4-160KW

SHENZHEN ENCOM ELECTRIC TECHNOLOGIES CO.,LTD.

Foreword

First of all, thank you for purchasing the ENA100 series inverter developed and produced by Shenzhen Encom Electric Technologies Co., Ltd.!

The ENA100 series vector inverter adopts advanced control methods to realize the high torque, high precision and wide speed regulation drive of three-phase asynchronous motors and three-phase permanent magnet synchronous motors. Provide customers with practical main and auxiliary frequency setting, operating channel frequency binding, PID regulator, simple PLC, textile swing frequency, programmable input and output terminal control and built-in Modbus, 485 free protocol and other functions, provide highly integrated solutions for customers in manufacturing and automation engineering. The ENA100 series has built-in protection functions such as phase loss protection, short-circuit protection to ground, and fast current limiting, which effectively improves the reliability and safety of the system.

This brochure provide the installation and wiring, settings, fault check and methods, maintenance and other relative issues to customer. To make inverter assemble and operate rightly, and use its high performance to best, please read this brochure carefully before installation usage and keep them well to the final users of inverter.

Please contact our office or dealer anywhere at any moment when you have any doubts or special demands in using these inverters, and you can also contact our after service center in our Headquarters directly. We will serve you with all our heart.

We reserve our right to notice you if we change contents of this manual.

Content

1	Safety information and use notice points.....	1
1.1	Safety precautions	1
1.2	Application range	3
1.3	Use notice points	3
1.4	Scraping handling notice.....	4
2	Inverter type and specification.....	5
2.1	Incoming inverter inspect.....	5
2.2	Type explanation	5
2.3	Nameplate explanation.....	6
2.4	Inverter type explanation.....	6
2.5	Appearance and parts name explanation.....	7
2.6	Outer size.....	7
2.7	Outer size of keypad.....	9
2.8	Product technic index and spec	9
3	Installation and wiring.....	13
3.1	Installation ambient	13
3.1.1	The demands for installation ambient.....	13
3.1.2	Installation direction and space.....	13
3.2	Parts disassembly and installation.....	14
3.2.1	Keyboard disassembly and installation.....	14
3.2.2	Cover disassembly and installation.....	15
3.3	Wiring notice points	16
3.4	Main loop terminal wiring.....	17
3.4.1	Connection between inverter and fitting parts.....	18
3.4.2	Main loop terminal wiring	19
3.5	Basic running wiring diagram.....	21
3.6	Control loop collocation and wiring	21
3.6.1	Introduction of the relative position and function of the control board terminal and jumper	21
3.6.2	Descriptions for control board terminal.....	23
3.6.3	Analog input & output terminal wiring	25
3.6.4	Wiring of digital input terminal	26
3.6.5	Communication terminal wiring	26
4	EMC (Electromagnetic compatibility) explanation.....	28
4.1	Noise interference restraining	28

4.1.1	Interference noise type	28
4.1.2	Basic countermeasure for restrain interference	29
4.2	Field wiring and earth grounding	29
4.3	Leak current and countermeasure	30
4.4	Installation demand for electromagnetic on-off electronic device	31
4.5	Noise filter installation instructions	31
5	Run and operation explanation for inverter	32
5.1	Run of inverter.....	32
5.1.1	Running order channels	32
5.1.2	Frequency-provision channel.....	32
5.1.3	Work state	33
5.1.4	Run mode	33
5.2	Operation and use of key board.....	35
5.2.1	Keypad layout	35
5.2.2	Keypad function description	36
5.2.3	LED and indicator light.....	36
5.2.4	Key board display status	37
5.2.5	User Management Parameters	39
5.2.6	Method for operating keypad.....	40
5.3	Inverter electrification	42
5.3.1	Check before electrification	42
5.3.2	First electrification	43
6	Function parameter schedule graph	44
6.1	Symbol description.....	44
6.2	Function parameter schedule graph	44
7	Detailed function specification	105
7.1	System Parameter Group: F00	105
7.2	Basic Run Function Parameter Group: F01	113
7.3	Start, Stop, Forward/Reverse, Brake function Parameter Group: F02	122
7.4	V/F control Parameter Group: F03	127
7.5	Auxiliary running Parameter Group: F04	130
7.6	Communication control Parameter Group: F05.....	136
7.7	Setting curve Parameter Group: F06.....	140
7.8	Analog quantity, Pulse input function Parameter Group: F07.....	143
7.9	On-off input function Parameter Group: F08	147
7.10	Switch output function Parameter Group: F09	162
7.11	Simple PLC/Multi-speed function Parameter Group: F10	174



7.12 Closed-Loop PID operation Parameter Group: F11	181
7.13 Constant pressure water supply function Parameter Group: F12	187
7.14 Traverse, Fixed-length control function Parameter Group: F13.....	190
7.15 Vector Control Parameter Group: F14.....	194
7.16 Motor Parameter Group: F15	203
7.17 Closed-loop encoder Parameter Group: F16.....	207
7.18 Reserved Parameter Group: F17	207
7.19 Enhanced Control Functions Parameter Group: F18	207
7.20 Protective Relevant Function Parameter Group: F19	212
7.21 Internal Virtual Input Output Node Parameter Group: F20.....	223
7.22 Reserved Parameter Group: F21	225
7.23 Reserved Parameter Group: F22	225
7.24 Reserved Parameter Group: F23	225
7.25 Lifting special Parameter Group: F24.....	225
7.26 User Definition Display Parameter Group: F25	227
7.27 Fault Record Function Parameter Group: F26.....	229
7.28 Password and Manufacturer Function Parameter Group: F27.....	231
8 Troubleshooting	232
8.1 Failure and countermeasure	232
8.2 Failure record lookup	238
8.3 Failure reset	239
8.4 Alarm reset	239
9 Maintenance	240
9.1 Routine maintenance	240
9.2 Inspection and replacement of damageable parts	240
9.3 Repair guarantee.....	241
9.4 Storage.....	241
Appendix A Modbus communication protocol	242
Appendix B Free-port communication protocol.....	257
Appendix C Keyboard.....	271
Appendix D Application Macros	275
Appendix E Braking unit and braking resistance	286

1 Safety information and use notice points

To make ensure personal & equipment safety, this chapter must be read carefully before the inverter come into use.

1.1 Safety precautions

There are three kinds of safety warnings in this manual as below:

Symbol	Symbol description
	It may cause human death, serious injury or heavy property loss with wrong operation.
	It may result body or device damage with wrong and timeless precautions under operation.
 Note	Should pay extra cautions when inverter in use under this symbol



Forbid to cut off the power source directly when inverter under running, acceleration or deceleration status. Power source could cut off when inverter completely in halt and standby status. Otherwise user should be responsible for inverter and device damage and human injury.



- (1) Forbid to connect AC power source to output terminal U, V, W, otherwise it could cause inverter completely damage.
- (2) Not allow for short circuit between (-) and (+), Otherwise it could cause inverter damage and power source short circuit.
- (3) Forbid to install inverter on flammable objects, otherwise it may cause fire.
- (4) Do not install inverter in a environment with explosive gas, it may cause explosion.
- (5) Bare connection terminal should be insulation treatment after main loop connection, otherwise it may cause electric shock.
- (6) Do not operate inverter with wet hands when inverter power on, otherwise it may cause electric shock.
- (7) Inverter earth terminal should be well grounding connection.
- (8) Do not open the front cover for wiring when inverter power on. Inverter wiring and check must handle after 10 minutes of inverter power off.
- (9) Wiring connection should handle by qualified person and not allow to slip any conductive objects inside inverter, otherwise it may cause a electric shock or inverter damage.
- (10) When inverter stocked for more than 6 months, using voltage regulator to boost voltage up and keep inverter in standy status for 1 hour, otherwise it may cause electric shock and explosion.



- (1) Forbid to connect control terminals except TA, TB, TC to AC 220V/380V signal, otherwise it may cause inverter completely damage.
- (2) Do not install and run inverter when inverter damage or spare part less, otherwise it may cause fire or human injury.
- (3) Inverter should install in a place where can accept itself weight, otherwise it may cause inverter drop down or belongings damage.

1.2 Application range

(1) This kind of inverter apply to 3 phase ac asynchronous motor only for general industry.

(2) It should handle cautiously and consult with manufacturer when inverter apply to high reliability required equipment which relevant to life, properties and safety device.

(3) This kind of inverter is the general motor control device in industry. When inverter apply to dangerous equipment, safeguard should be considerable in case of inverter failure.

1.3 Use notice points

(1) ENA100 series inverter belong to voltage type inverter, and it is normal with up temperature, noise and vibration of motor increasing over power frequency run slightly.

(2) It is required to match inverter with variable frequency motor running at low speed with constant torque for long time. When match inverter with general asynchronous motor running at low speed, it should take measures to make motor heat dissipation or monitoring motor temperature in avoid of motor flash.

(3) It is necessary to take measures in advance for the damage caused for the bad lubrication of the reduction box and wheel gear mechanical devices running at low speed for long time.

(4) It is necessary to assure at first that the use speed range of motor bearings and mechanical devices, also the increasing of motor vibration and noise should be considered, when motor run over rated frequency.

(5) It is necessary to select the suitable brake assembly for hoisting device and big inertia load to make sure the normal work when inverter stripping from power grid for the over current or overvoltage failure.

(6) Inverter start and stop control through terminal or other normal command channel, otherwise it may cause inverter damage via connecting inverter input terminal to big current switch just like contactor direct to start and stop inverter frequently.

(7) It is necessary to make sure inverter cut off from operation without output, when inverter and motor connect through switch components just like contactor etc. Otherwise it will cause inverter damage.

(8) When inverter output frequency within some range, it may meet mechanical resonance point of load device, through setting jump frequency to avoid it.

(9) Checking power supply voltage within allowed working range before usage, otherwise, It need to change voltage or custom special voltage inverter.

(10) When inverter usage site altitude over 1000 meters, inverter should derate

current to use, output current decrease about 10% of rated current per 1000 meters increase.

(11) Motor should do insulation check before first usage or reusage after lay aside for long time. Checking method show as Fig.1-1 below with 500V voltage type megohm meter , insulation resistance should not smaller than 5 M Ω , otherwise inverter maybe damaged.

(12) Forbid inverter output side to assemble capacitor to improve power factor or anti-thunder dependent resistor etc, otherwise it may cause inverter fault trip or component damage show as Fig.1-2.

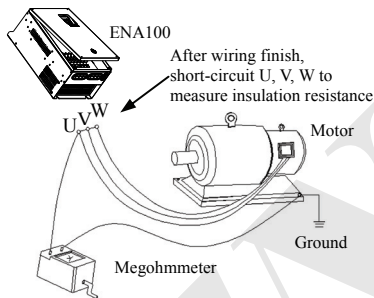

Fig.1-1 Schematic diagram of motor insulation inspection

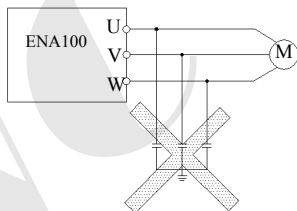

Fig.1-2 Capacitor at output side forbidden

1.4 Scraping handling notice:

Notices when handling with scrapped inverter and components:

- (1) The unit: Dispose the inverter as industrial waste.
- (2) Electrolytic capacitor: It may cause explosion when electrolytic capacitor under burning.
- (3) Plastic: It may result in harmful and poisonous gas when plastic and rubber of inverter burning, and safeguard preparations should be taken before burning.

2 Inverter type and specification

2.1 Incoming inverter inspect

(1) Check if there is damage during transportation and inverter itself has damage or fall-off parts.

(2) Check if parts presented in packing list are all ready.

(3) Please confirm nameplate data of the inverter is in line with your order requirement.

Our product is guaranteed by strict quality system during manufacturing, Packing, transportation etc., please contact our company or local agent rapidly if some careless omission or mistake arise, we'll deal with it as soon as possible.

2.2 Type explanation

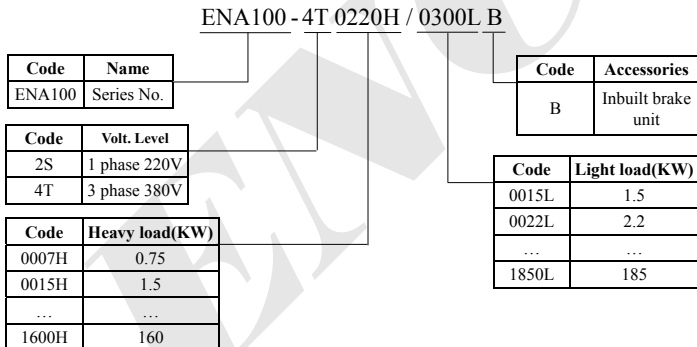

Fig.2-1 Type description

2.3 Nameplate explanation

Nameplate presented as Fig.2-2 with type and rating data at the bottom of inverter right side.

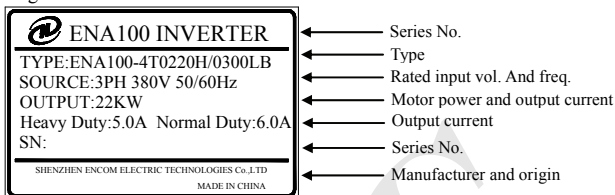

Fig.2-2 Nameplate

2.4 Inverter type explanation

Input Volt.	Model	Heavy load (H)		Light load (L)	
		Rated output current (A)	Adaptable motor (KW)	Rated output current (A)	Adaptable motor (KW)
Single phase 220V	ENA100-2S0004B	2.5	0.4	3.0	-
	ENA100-2S0007B	4.0	0.75	4.6	-
	ENA100-2S0015B	7.0	1.5	8.4	-
	ENA100-2S0022B	10.0	2.2	11.0	-
Three phase 380V	ENA100-4T0007H/0015LB	2.3	0.75	2.8	1.5
	ENA100-4T0015H/0022LB	3.7	1.5	4.3	2.2
	ENA100-4T0022H/0037LB	5.0	2.2	6.0	3.7
	ENA100-4T0037H/0055LB	8.5	3.7	9.8	5.5
	ENA100-4T0055H/0075LB	13.0	5.5	15.6	7.5
	ENA100-4T0075H/0110LB	17.0	7.5	19.6	11
	ENA100-4T0110H/0150LB	25.0	11	28.8	15
	ENA100-4T0150H/0185LB	33.0	15	34.7	18.5
	ENA100-4T0185H/0220LB	39.0	18.5	44.9	22
	ENA100-4T0220H/0300LB	45.0	22	49.5	30
	ENA100-4T0300H/0370L	60.0	30	72.0	37
	ENA100-4T0370H/0450L	75.0	37	82.5	45
	ENA100-4T0450H/0550L	91.0	45	109.2	55
	ENA100-4T0550H/0750L	112.0	55	134.4	75
	ENA100-4T0750H/0900L	150.0	75	172.5	90
	ENA100-4T0900H/1100L	176.0	90	200.0	110
ENA100-4T1100H/1320L	210.0	110	235.0	132	
ENA100-4T1320H/1600L	253.0	132	290.0	160	
ENA100-4T1600H/1850L	304.0	160	330.0	185	

2.5 Appearance and parts name explanation

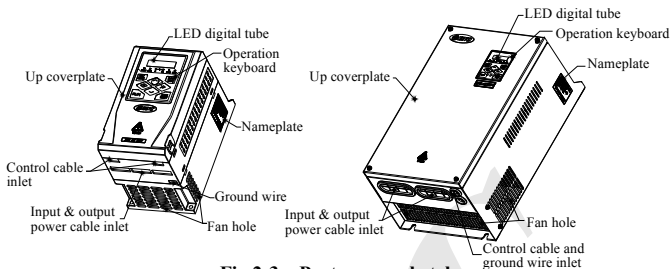

Fig.2-3 Parts name sketch

2.6 Outer size

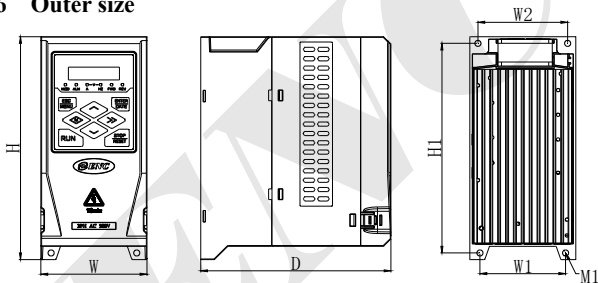

Fig.a

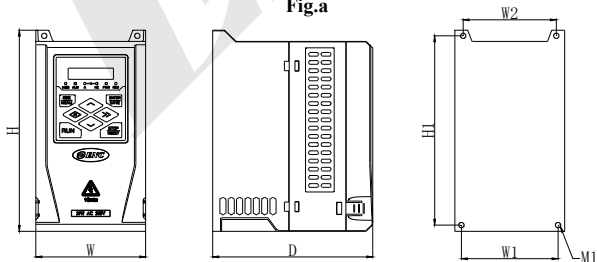

Fig.b

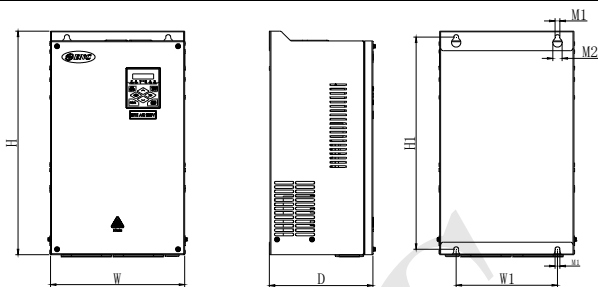

Fig.c

Fig.2-4 Outline drawing table

Table 2-1 Mounting size

Model	H (mm)	H1 (mm)	W (mm)	W1 (mm)	W2 (mm)	D (mm)	M1 (mm)	M2 (mm)	Fig. No.	
ENA100-2S0004B	167	157	78	63	66	140	φ4.5	-	Fig.a	
ENA100-2S0007B										
ENA100-2S0015B	171.5	161.5	92	81	78	134	φ4.5	-	Fig.b	
ENA100-2S0022B										
ENA100-4T0007H/0015LB	167	157	78	63	66	140	φ4.5	-	Fig.a	
ENA100-4T0015H/0022LB										
ENA100-4T0022H/0037LB	171.5	161.5	92	81	78	134	φ4.5	-	Fig.b	
ENA100-4T0037H/0055LB										
ENA100-4T0055H/0075LB	229	217	120	105	108	162	φ5.5	-		
ENA100-4T0075H/0110LB										
ENA100-4T0110H/0150LB	291	276	160	144	141	180.5	φ6	-		
ENA100-4T0150H/0185LB										
ENA100-4T0185H/0220LB	291	276	190	174	171	180	φ6.5	-		
ENA100-4T0220H/0300LB										
ENA100-4T0300H/0370L	415	394	245	185	-	189	φ9	φ17		Fig.c
ENA100-4T0370H/0450L										
ENA100-4T0450H/0550L	482	466	290	210	-	210	φ9	φ17		
ENA100-4T0550H/0750L										
ENA100-4T0750H/0900L	482	466	333	220	-	205	φ9	φ17		
ENA100-4T0900H/1100L										
ENA100-4T1100H/1320L	610	595	335	255	-	290	φ9	φ14		
ENA100-4T1320H/1600L										
ENA100-4T1600H/1850L	730	698	400	280	-	290	φ13	φ25		

2.7 Outer size of keypad

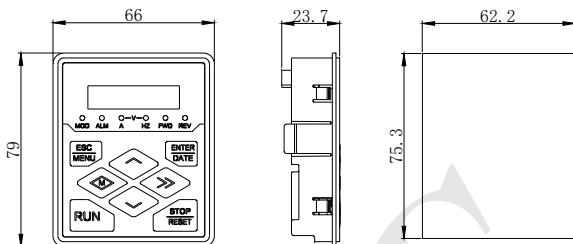

Fig.2-5 Keyboard appearance



(1) If the local keyboard needs to be used as the external cited keyboard, it must be used with ENA100 components (The external cited accessories of local keyboard and 2 meters keyboard cable).

(2) When the local keyboard is used as the external cited keyboard, if the user does not to use the ENA100 supporting components as requirement, and it caused the Drive damage, equipment damage and personal safety accidents, all of the damages shall be borne by the user.

2.8 Product technic index and spec

Item		Item description
Input	Rating volt., frequency	1 phase 220 grade: 1 phase 220V, 50Hz/60Hz 3 phase 380 grade: 3 phase 380V, 50Hz/60Hz
	Allowed volt. range	1 phase220VGrade: 200~260V 3 phase380VGrade: 320~460V
Output	Voltage	0~Input voltage
	Frequency	0~600Hz
	Over loading capacity	Heavy Load: 150% of rated current for1minute; Light Load: 120% of rated current for 1 minute.
Control performance	Control mode	Without PG vector control, open loop V/F control, Without PG torque control, support synchronous and asynchronous motors
	Velocity control precision	±0.5% rated synchronous speed (Without PG Vector control); ±1% rated synchronous speed (V/F control);
	Speed regulation range	1:100 (Without PG Vector control); 1:50 (V/F control);

2 Inverter type and specification

	Start-up torque	1.0Hz: 150% rated torque (V/F control); 0.5Hz: 180% rated torque (Without PG Vector control);
	Speed fluctuation	±0.3% rated synchronous speed (Without PG vector control, Without PG torque control);
	Torque response	≤20ms (Vector control)
	Frequency precision	Digital setting: max. frequency×±0.01%; Analog setting: max. frequency×±0.5%
Freq. resolution	Analog setting	0.1% of max. frequency
	Digital setting precision	0.01Hz
	Exterior impulse	0.1% of max. frequency
	Torque boost	Automatic torque boost; manual torque boost 0.1~12.0%
	V/F curve (Volt. Frequency characteristic)	Setting rated frequency at the range of 5~600Hz, by choosing constant torque, decreasing torque 1, decreasing torque 2, decreasing torque 3, self-defined V/F total5 kinds of curve.
	Acceleration Deceleration curve	Two methods: linear acceleration and deceleration and S curve acceleration and deceleration; 15 kinds of acceleration and deceleration time, time unit (0.01s, 0.1s, 1s)
Brake	Power consumption brake	ENA100 series three-phase 22KW and below power section has built-in braking unit, only need to add braking resistor between (+) and PB; 30KW and above can connect external braking unit between (+) and (-) to achieve Energy consumption braking.
	DC brake	Start, stop action for option, action frequency0~15Hz, action current0~100% of rated current, action time0~30.0s
	Jog	Jog frequency range: 0Hz~uplimit frequency; jog acceleration and deceleration time 0.1~6000.0 seconds for setting.
	Multi-section speed run	Realized by in built PLC or control terminal; With 15 section speed, each section speed with separately acceleration and deceleration time; with inbuilt PLC can achieve reserve when power down.
	Inbuilt PID controller	Convenient to make closed-loop control system
	Automatic energy saving run	Optimize V/F curve automatically to achieve power saving run according to the load status.
	Automatic voltage regulate(AVR)	Automatically keep output voltage constant, when the power grid voltage fluctuation
	Automatic current limiting	Current limited automatically under run mode in avoid of inverter over-current frequently to trip.
	Carrier modulation	Modulate carrier wave automatically according to the load characteristic.
	Speed tracking restart	Make rotating motor smoothly start without shocking

Running function	Running command specified channel	Keypad specified, control terminal specified, communication specified can switch through various means.
	Running frequency specified channel	Main & auxiliary specified to realize one main adjusting and one fine control. Digital specified, analog specified, pulse specified, pulse width specified, communication specified and others, which can be switched by many means at any time.
	Binding function	Run command channel and frequency specified channel can bind together randomly and switch synchronously
Input output characteristic	Digital input channel	5 general-purpose digital input channels, the maximum frequency is 1KHz, one of which can be used as a pulse input channel, the maximum input is 20KHz
	Analog input channel	2 analog input channels, of which AI1 is 0~10V output, AI2 channel is 0~20mA or 0~10V input optional.
	Pulse output channel	0.1 ~ 20KHz pulse square signal output to achieve setting frequency, output frequency and other physical quantity output.
	Analog output channel	1 analog signal output, AO1 channel can choose 0~20mA or 0~10V to realize the output of physical quantities such as set frequency and output frequency
	Digital output	2 Y outputs, Y2 can achieve the highest frequency output of 20K, 1 Rel output
Unique function	Rapid current limit	Limit inverter over current to the greatest point, and make it run more stably
	Mono pulse control	Suitable for working site where need one button to control inverter start and stop, first press to start, then press to stop, and that cycle repeats. It's very simple and reliable.
	Fixed length control	Realize fixed length control
	Timing control	Timing control function: setting time range 0.1 Min~6500.0Min
	Virtual terminal	Five group virtual input & output IO can realize simply logical control
Keypad	Keypad display	The parameters as setting frequency, output frequency, output voltage, output current can be displayed
	Button Locked	Lock all or part of the buttons
	Dual keyboard operation	Can use external keyboard to achieve dual keyboard control (local and remote control)
Protection function		Motor power on Shot circuit test, input & output phase loss protection, over-current protection, overvoltage protection, under voltage protection, over heat protection, overload protection, under load protection, relay absorption protection, terminal protection and no stop protection under power off.
monir	Application site	Indoor, not bare to sunlight, no dust, no corrosive gas, no flammable gas, no vapor, no water drop or salt etc.

2 Inverter type and specification

	Altitude	Under1000meter. (above1000meter require to reduce volume to use, output current reduce about 10% of rated current volt per1000 meter high)
	Environment temperature	-10°C ~ +50°C
	Environment humidity	Smaller than 95% RH, no drop condensens
	Vibration	Smallerthan5.9 M/S ² (0.6g)
	Storage temperature	-40°C ~+70°C
Structure	Protection grade	IP20
	Cooling mode	Forced air cooling and natural
Installation mode		Wall hanging and cabinet installation



Note

To get a perfect usage performance of the inverter, Please check and select right type according to this chapter before wiring.



It is necessary to select right type, otherwise it may cause motor abnormal run or inverter damage.

3 Installation and wiring

3.1 Installation ambient

3.1.1 The demands for installation ambient

(1) Installed in drafty indoor place, The ambient temperature should be with in $-10^{\circ}\text{C}\sim 50^{\circ}\text{C}$, It needs external compulsory heat sink or reduce the volume if Temperature is over than 50°C ; when temperature under -10°C , please preheat inverter first.

(2) Avoid installing in places with direct sunlight, much dust, floating fiber and metal powder.

(3) Don't install in place with corrosive, explosive gas.

(4) The humidity should be smaller than 95% RH, without condensation water.

(5) Installed in place of plane fixing vibration smaller than 5.9m/s^2 (0.6g).

(6) Keep away from electromagnetic disturbance source and other electronic apparatus sensible to electromagnetic disturbance.

3.1.2 Installation direction and space

(1) Normally the inverter should be mounted vertically, horizontal mounting will seriously affect heat dissipation and the inverter must be used in lower volume.

(2) Demand for minimum mounting space and distance, please see Fig.3-1.

(3) When installing multiple inverters up and down, leading divider must be applied between them, see Fig.3-2.

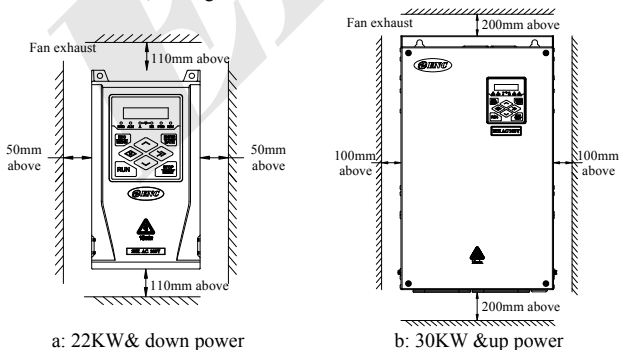

Fig.3-1 Mounting space

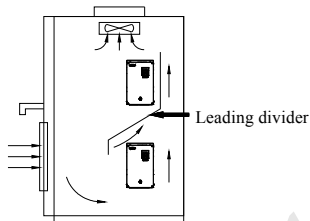

Fig.3-2 Mounting of multiple inverters

3.2 Parts disassembly and installation

3.2.1 Disassembly and installation of cover

3.2.1.1 Disassembly and installation of plastic cover

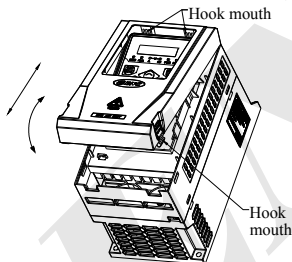

Fig.3-3 Disassembly and installation diagram of plastic cover

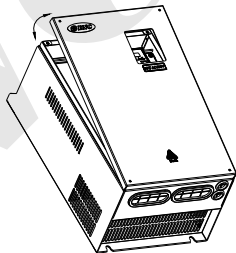

Fig.3-4 Removal and installation diagram of sheet metal cover

(1) Disassembly

Place the thumbs or index fingers of the left and right hands on the buckle grooves on the left and right sides of the cover, press inward and lift up until the buckle on the left and right sides of the cover and the middle shell are released, then move the cover down until the top of the cover snaps off the middle shell, then the cover can be removed, as shown in Fig.3-3.

(2) Installation

Align the two buckles on the upper end of the cover with the middle shell, and then press the cover down until the buckles on the left and right sides of the cover enter the middle shell slot.

3.2.1.2 Disassembly and installation of sheet metal cover

(1) Disassembly

Firstly, remove the four screws on the cover, hold the slightly upper part of the cover, lift it up, and then remove the cover.

(2) Installation

Lower the cover slowly so that the square holes of the cover are just stuck on the keyboard, and then tighten the four screws on the cover, and the cover is installed. As shown in Fig.3-4.

3.2.2 Disassembly and installation of operating keyboard

(1) Disassembly

Use the thumb and middle finger to press the buckles on the left and right sides of the keyboard while holding the case with hand. After the buckles are released, pull them outward to separate the keyboard from the socket of the main control board, and you can remove the operating keyboard.

(2) Installation

After aligning the keyboard with the socket of the main control board, press down and at the same time press the buckles on the left and right sides of the keyboard with your thumb and middle finger, and release them when they are in site, as shown in Fig. 3-5.

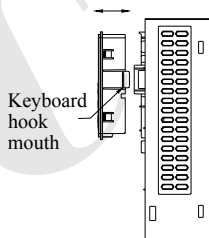

Fig.3-5 Installation diagram of operation keyboard

3.3 Precautions for inverter wiring



(1) Before wiring, make sure that the power has been completely cut off for more than 10 minutes, otherwise there is a danger of electric shock.

(2) Forbid connecting power wire to output U, V, W of the inverter.

(3) If there is current leakage inside inverter, inverter and motor must be earth grounding for safety assurance, please refer to clause 8 in Chapter 3.4.1 for grounding wiring.

(4) Before shipment compression resistance test of the inverter is Passed, so users should not conduct compression resistance test again.

(5) Do not add absorbing capacitor or other resistance-capacitor absorbing device between inverter and motor; also do not add electromagnetic contact. If contactor and other switch component needed to add, please make sure inverter suspended without output, show as Fig.3-6.

(6) To provide inverter over-current protection in output side and convenient maintenance under power off, it should be connected to power source through air switch and contactor.

(7) Control signal wire should select multi-core stranded wire or shielding wire. One end of the shielding layer hang in the air, and the other end connect to inverter earth grounding terminal, connection wire shorter than 20m.



(1) Make sure the inverter power supply is completely cut off. Operation keypad LED display off, Wait more than 10 minutes according to the mode of inverter, then wiring can be done.

(2) Before inverter internal wiring, confirm that DC volt Between main loop end P+ and P- fall down to below DC 36V.

(3) Wiring can only be done by professional person trained and qualified.

(4) Before power on, check if voltage grade of the inverter is in line with that of power supply volt., other wise will cause personnel injured and device damaged.

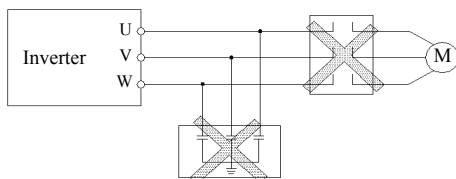

Fig.3-6 Forbid to use contactor and absorbing capacitor

3.4 Main loop terminal wiring

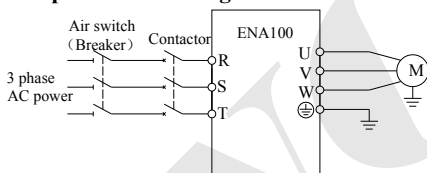

Fig.3-7 Main loop simple wiring

To keep user power grid safety, please choose proper air switch, breaker, wiring at power input side, parameter recommended show as Table 3-1 (**Remark: wire must choose PVC insulation copper conductor**).

Table 3-1 Parameter recommended for air switch (Breaker), contactor and wire selection

Model	Air breaker or circuit breaker (A)	Contactor (A)	Input power cable mm ²	Output motor cablemm ²	Control signal wire mm ²
ENA100-2S0004B	6	9	0.75	0.75	0.5
ENA100-2S0007B	10	12	0.75	0.75	0.5
ENA100-2S0015B	16	18	1.5	1.5	0.5
ENA100-2S0022B	16	18	1.5	1.5	0.5
ENA100-4T0007H/0015LB	6	9	0.75	0.75	0.5
ENA100-4T0015H/0022LB	10	12	0.75	0.75	0.5
ENA100-4T0022H/0037LB	16	18	1.5	1.5	0.5
ENA100-4T0037H/0055LB	16	18	1.5	1.5	0.5
ENA100-4T0055H/0075LB	20	25	2.5	2.5	0.75
ENA100-4T0075H/0110LB	25	25	4.0	4.0	0.75
ENA100-4T0110H/0150LB	32	32	6.0	6.0	0.75
ENA100-4T0150H/0185LB	40	40	6.0	6.0	0.75
ENA100-4T0185H/0220LB	50	50	10	10	1.0

3 Installation and wiring

ENA100-4T0220H/0300LB	50	50	10	10	1.0
ENA100-4T0300H/0370L	63	63	16	16	1.0
ENA100-4T0370H/0450L	80	80	25	25	1.0
ENA100-4T0450H/0550L	100	115	35	35	1.0
ENA100-4T0550H/0750L	125	125	50	50	1.0
ENA100-4T0750H/0900L	250	160	70	70	1.5
ENA100-4T0900H/1100L	250	160	75	75	1.5
ENA100-4T1100H/1320L	350	350	120	120	1.5
ENA100-4T1320H/1600L	400	400	120	120	1.5
ENA100-4T1600H/1850L	500	500	150	150	1.5

3.4.1 Connection between inverter and fitting parts

(1) Breaking device like isolation Switch must assemble between power source and inverter to keep persona safety under repairing and inverter requirement for compulsory power off.

(2) There must be over-current Protection breaker or fuse in inverter power supply circuit to avoid failure expanding because of the second device failure.

(3) AC input reactor

When high harmonics between inverter and power supply is strong which cannot meet system requirement or input side power factor need to improve, ac input reactor can be added.

(4) Contactor is used to power supply only, Do not use it to control inverter start and stop.

(5) Input side EMI filter

Hoosing optionally EMI filter to restrain high frequency transduction interference and radio-frequency interference from inverter power line.

(6) Output side EMI filter

Choosing optionally EMI filter to restrain radio-frequency Interference and wire leakage current from inverter

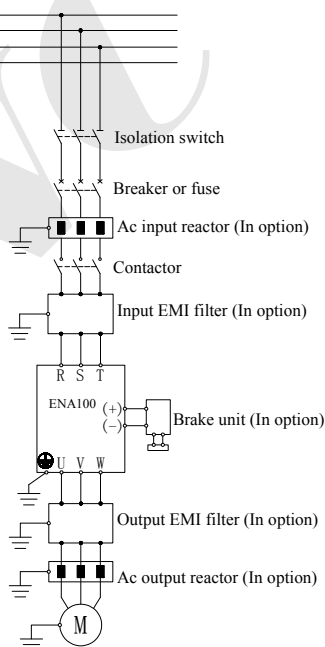

Fig.3-8 Connection of inverter and fitting parts

output side.

(7) AC output reactor

Installing AC output reactor is suggested to avoid motor insulation damage, oversize current leakage and inverter frequent protection when connecting wire between inverter and motor exceeds 50m.

(8) Safety earth ground wire



Inverter and motor must be earth ground connection, connection wire should select as shorter and thicker as above 3.5mm² multicore copper wire, and earth grounding resistance smaller than 10Ω.

3.4.2 Main loop terminal wiring

Table 3-2 Description of ENA100 series main circuit input and output terminals

Adapted type	Main loop terminal	Terminal name	Function description
ENA100-2S0004B ENA100-2S0007B ENA100-4T0007H/ 0015LB ENA100-4T0015H/ 0022LB		PB	External connect to brake resistor reverse terminal
		(+)	DC volt. Positive terminal
		(-)	DC volt. Negative terminal
		R/L1、S/L2、T/L3	AC input terminal, connect power source
		U、V、W	AC output terminal, connect to motor
			Ground terminal
ENA100-2S0015B ENA100-2S0022B ENA100-4T0022H/ 0037LB ~ ENA100-4T0075H/ 0110LB		PB	External connect to brake resistor reverse terminal
		(+)	DC volt. Positive terminal
		(-)	DC volt. Negative terminal
		R/L1、S/L2、T/L3	AC input terminal, connect power source
		U、V、W	AC output terminal, connect to motor
			External connect to brake resistor reverse terminal
ENA100-4T0110H/ 0150LB ~ ENA100-4T0220H/ 0300LB		PB	External connect to brake resistor reverse terminal
		(+)	DC volt. Positive terminal
		(-)	DC volt. Negative terminal
		R/L1、S/L2、T/L3	AC input terminal, connect power source
		U、V、W	AC output terminal, connect to motor
			External connect to brake resistor reverse terminal

3 Installation and wiring

			resistor reverse terminal
ENA100-4T0300H/ 0370L ~		R, S, T	AC input terminal, connect power source
ENA100-4T0750H/ 0900L	R S T + - U V W	+	DC volt. Positive terminal
		-	DC volt. Negative terminal
		U, V, W	AC output terminal, connect to motor
ENA100-4T0900H/ 1100L ~		R, S, T	AC input terminal, connect power source
ENA100-4T1600H/ 1850L	R S T P + - U V W	P, +	AC input terminal, connect power source
		+	DC volt. Positive terminal
		-	DC volt. Negative terminal
		U, V, W	AC output terminal, connect to motor



The wiring of the main circuit must be correctly wired according to the terminal instructions. Wrong wiring will cause equipment damage and even personal injury.

3.5 Basic running wiring diagram

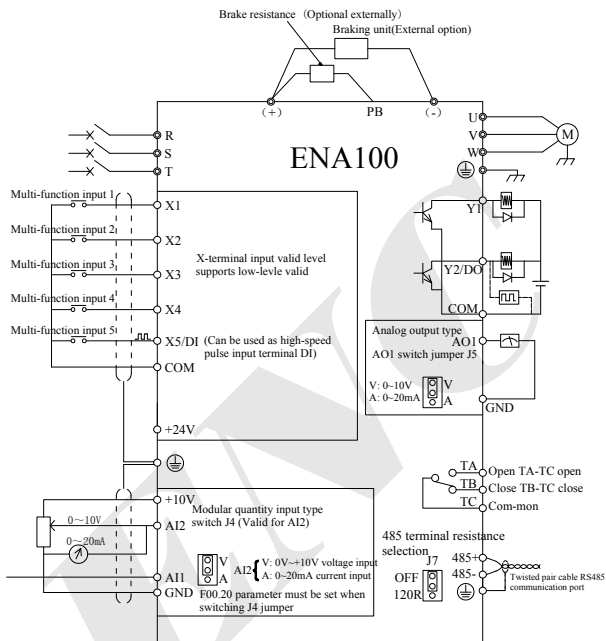

Fig.3-9 Basic wiring diagram

3.6 Control loop collocation and wiring

3.6.1 Introduction of the relative position and function of the control board terminal and jumper

Control board terminal and slide switch location show as Fig.3-10.

Terminals J3 and J6 are used by the manufacturer, J1 is the keyboard interface of the machine. For the function description of terminals J2, J8 and J9 provided to users, please refer to Table 3-3. For the function and setting description of jumper caps, refer to Table 3-4. Before using the inverter, please read the following carefully.

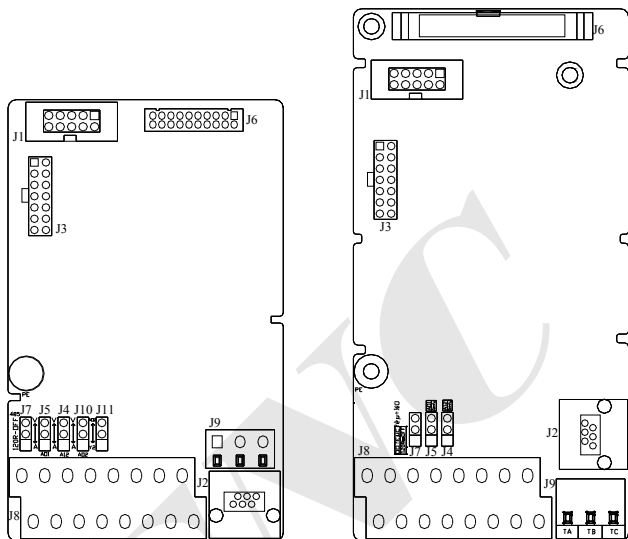

a: 7.5KW & down power







b: 11KW & up power

Fig.3-10 Sketch map of CPU board

Table 3-3 Function description of terminal provided for user

No.	Function	Description
J2	External keyboard port	Use RJ45 terminal, and extension cable is an ordinary network cable, preferably not longer than 3m
J8	External terminal input and output control	It is used when using external terminals to control the operation of the inverter, see Table 3-5 for details
J9	RLY1 signal output	TA-TC is a normally open contact; TB-TC is a normally closed contact, see Table 3-5 for details

Table 3-4 Description of jumper caps provided to users

No.	Function	Setting	Default value
J4	AI2 Analog input signal selection	 V: F00.20 be XXX0 0~+10V Voltage signal input	F00.20 be 0000 0~+10V
		 A: F00.20 be XXX1 0~20mA current signal input	
J5	AO1 Analog output signal selection	 V: F00.21 be XXX0 0~+10V Voltage signal input	F00.21 be 0000 0~+10V
		 A: F00.21 be XXX1 0~20mA current signal input	
J7	Terminal resistance selection	 OFF: Suspending	Suspending
		 120R: Connect to terminating resistor	

3.6.2 Descriptions for control board terminal

Table 3-5 shows the function description of control board wiring terminals J8 and J9.

Table 3-5 Function table for control board terminal

Type	Symbol	Description	Terminal Function and specification
Multifunction input Terminals	X1	Multifunction input 1	Input impedance: 4.7KΩ max input frequency: 1KHz
	X2	Multifunction input2	
	X3	Multifunction input3	
	X4	Multifunction input4	
Power source	X5/DI	Multifunction input 5/ high-speed pulse input	Except for X1 ~ X4 function , it can be used as hi-speed pulse input. Input impedance: 2.2KΩ max input frequency: 20KHz
	+24V	+24V power source	Provide +24V power to external device (24±4V) Max output current: 100mA
	+10V	+10V power source	Provide external +10V power supply (10±0.5V) Maximum output current: 20mA
	COM	Common interface	Reference ground for digital signal and +24V power supply

3 Installation and wiring

	GND	Common interface	Reference ground for analog signal and +10V power supply
Analog input	AI1	Analog input1	Input range: DC 0V ~ 10V Input impedance: 20K Ω for voltage input; Resolution: 12 bits
	AI2	Analog input2	Input range: 0V ~ 10V/0 ~ 20mA, determined by the tens place of parameter F00.20 and the J4 jumper on the control board. Input impedance: 20K Ω for voltage input; 250 Ω for current input. Resolution: 12 bits
Analog output	AO1	Analogoutput1	Voltage or current output, selected by the J5 jumper on the control board Output voltage range: 0 ~ 10V Output current range: 0 ~ 20mA
Multi-function Can lose Out child	Y1	Open collector output terminal 1	Opto coupler isolation output, unipolar Open circuit collector output Max voltage output: 30V Max current output: 50mA
	Y2/DO	Open collector output terminal 2 / high-speed pulse output	Function code F00.22 to select terminal output mode When Open circuit collector output, with the same spec as terminal Y. When High-speed impulse Output, the max frequency is 20KHz.
RLY1 output	TB-TC	Normal closed terminal	Contact capacity: AC250V/2A ($\cos\phi=1$) AC250V/1A ($\cos\phi=0.4$) DC30V/1A
	TA-TC	Normal open terminal	
Communication Terminal	485+	485 differential signal terminal	485 differential signal positive terminal
	485-		485 differential signal negative terminal



Note

7.5KW and below power COM and GND are connected internally.

3.6.3 Analog input & output terminal wiring

(1) AI1 terminal accepts single-ended input of analog voltage signal, which is switched by switch SW1. The wiring method is as follows:

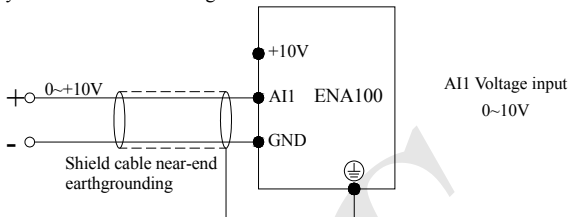

Fig.3-11 AI1 terminal wiring diagram

(2) AI2 terminal accepts single-ended input of analog voltage or current signal, which is switched by switch SW2, and the tens place of parameter F00.20 must be correctly set to match it. The wiring method is as follows:

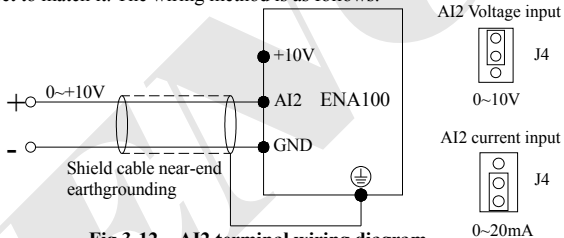

Fig.3-12 AI2 terminal wiring diagram

(3) The external analog meter of AO1 terminal can indicate a variety of physical quantities, and can choose to output analog voltage or current signals, which can be switched by switch J5. The wiring method as follows:

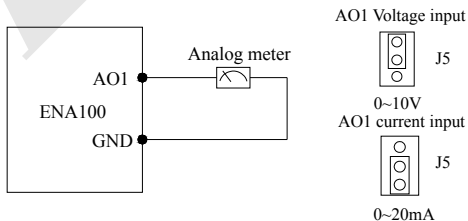

Fig.3-13 AO1 terminal wiring diagram

**Note**

(1) Under analog input mode, filter capacitor or common mode choke can be installed between AI1 and GND or AI2 and GND.

(2) Analog input and output signal can be interfered easily by ambient environment, it need use shield cable for connection and earth grounding well as short as possible.

3.6.4 Wiring of digital input terminals

To use inverter inbuilt +24V power supply, and NPN source type external controller connection mode.

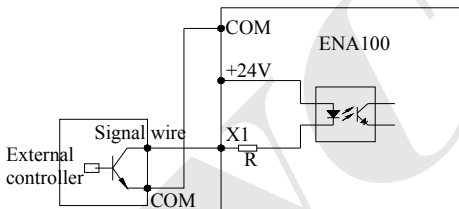

Fig.3-14 Inbuilt 24V source type connection mode

3.6.5 Communication terminal wiring

ENA100 inverter provide RS485 serial communication interface to user. The following wire connection can make up of single-main single-sub control system or single-main multi-sub control system. To use host computer softwar (PC or PLC controller) can realize real time monitoring and operation to inverter, and to achieve complicated run control like long-distance control, high degree automation. It can also use a host inverter and the other slave inverter to make up of the cascade or synchronous control inverter network.

(1) Inverter RS485 interface and other device with RS485 interface wire connection show as following

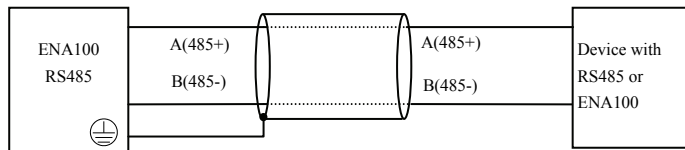

Fig.3-15 Communication terminal wiring

(2) Inverter RS485 interface and host computer (Device with RS232 interface) connection:

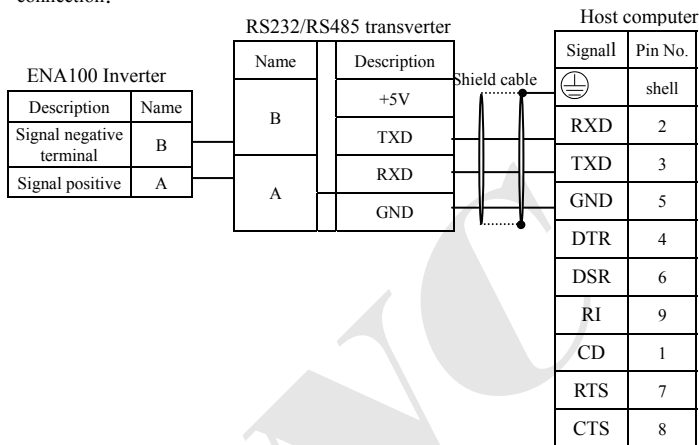

Fig.3-16 RS485 communication wiring

4 EMC(Electromagnetic compatibility)explanation

Because of inverter working principal resulting in electromagnetic noise, and to avoid or reduce inverter interference to ambient environment, this chapter introduce installation means to restrain interference from aspect of interference restrain, field wiring, system earth grounding, leakage current and power filter usage. Inverter will have good electromagnetic compatibility under general industrial environment, when user install the inverter according to this chapter.

4.1 Noise interference restraining

Inverter interference generating for run may have effect to nearby electronic device and the effect depend on the inverter installation surrounding electromagnetic environment and the restrain interference ability of the device.

4.1.1 Interference noise type

Because of inverter working principle, There are mainly 3 kinds of noise interference source:

- (1) Circuit conduction interference;
- (2) Space emission interference;
- (3) Electromagnetic induction interference;

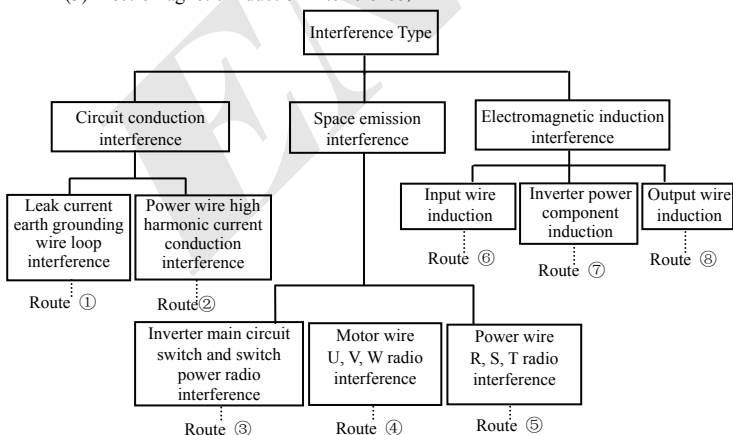

Fig.4-1 Interference noise type

4.1.2 Basic countermeasure for restrain interference

Table 4-1 Interference restrain countermeasure

Noise spread road	Countermeasure of weakening effect
①	Earth grounding cable of peripheral device and inverter wiring make up of the closed-loop and leakage current of inverter earth grounding cable will make device perform wrong action. It will decrease wrong action when device not connect to earth grounding.
②	When the power of peripheral device and inverter power belong to the same power source, high harmonic generating from inverter will transmit the voltage and current along with the power line which will interfere other devices within the same power source system. Take some restraining measures as below: install electromagnetic noise filter at inverter input end; use isolation transformer to isolate other devices; connect power end of peripheral device to remote power grid; add power ferrite filter magnetic ring to inverter R, S, T three phase wire to restrain high harmonic current conduction
③④⑤	<ul style="list-style-type: none"> ● Keep other sensitive devices and signal wire installed away from inverter. it should use shield wire and make the shield layer single end earth grounding. Besides keep distance from inverter and its input & output wire as possible as. When signal wire need to intersect with strong current cable, it should make them orthogonal crossing not parallel. ● Install high frequency noise filter (Ferrite common mode choke, also called magnetic ring) at the bottom end of the inverter input & output to restrain radio frequency interference of dynamic wire effectively. ● Motor cable should be placed in protective object with large thickness, such as placed in larger thickness (over 2mm) pipeline or buried in cemented tank. Putting dynamic wire in metal tube and connect to earth grounding with shield wire (motor cable use 4-core cable, one side is earthed through the inverter, the other side connected to motor casing).
⑥⑦⑧	To prevent wire parallel or bundled of strong and weak current, it should keep away from inverter assemble device, and wiring should away from inverter R,S,T,U,V,W equipower line. Devices with high field and high magnetic field should notice the corresponding installation position of inverter and keep distance and orthogonal crossing.

4.2 Field wiring and earth grounding

(1) Inverter terminal motor connection wire (U, V, W terminal output wire) and inverter terminal power connection wire (R, S, T terminal input wire) should keep distance enough as possible as can.

(2) U, V, W terminal 3 motor wires should be placed in metal tube or metal wiring tank as possible as.

(3) Generally control signal wire should use shield cable, when shield layer connect to inverter  terminal, it should be the single end earth grounding which closed to inverter side.

(4) Inverter  terminal earth grounding cable must directly connect to floor, it cannot connect to earth grounding through other device, and the location of earth grounding should close to inverter as possible as.

(5) Strong current cable (R, S, T, U, V, W) cannot parallel wiring closely with control signal wire, and bundled together is prohibited. It should keep distance from over 20~60 cm (Relative to strong current size). When it's necessary to intersect, it should be orthogonal crossing, show as Fig.4-2.

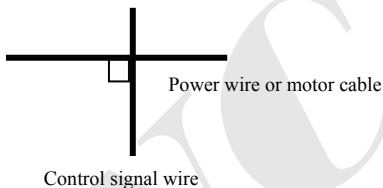

Fig.4-2 System wiring demand

(6) Earth grounding wire for strong current should separately connect to earth grounding with control signal and sensor earth grounding wire for weak current.

(7) Forbid to connect inverter input terminal (R, S, T) to other devices.

4.3 Leak current and countermeasure

The leak current flows through inverter input and output terminal for wire capacitance and motor capacitance, and its size decided by the distributed capacitance and carrier frequency. There are two kinds of leak current: leak current to earth and wire-to-wire. Restraining methods as below:

(1) Diminish the cable length between inverter and motor.

(2) Install ferrite magnetic ring or output reactor at the inverter output terminal.



When reactor installed with rated voltage drop more 5% and long wiring to U, V, W terminal, it would reduce motor's voltage apparently. When motor run at full load, it is possible to flash motor, and it should be used by derating or boosting input and output voltage.

(3) As carrier frequency low, the motor noise would increase accordingly.

4.4 Installation demand for electromagnetic on-off electronic device

It should pay attention that surge absorber must be installed when electromagnetic on-off electronic device like relay, electromagnetic contactor and electromagnetic iron generating noise easily and largely installed near to inverter or in the same control cabinet, show as Fig.4-3.

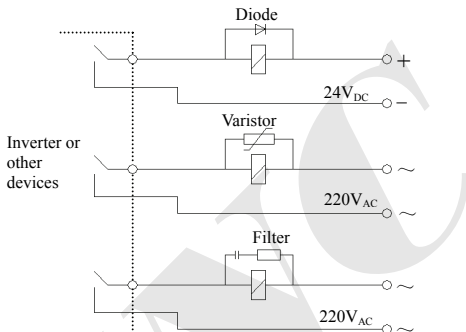

Fig.4-3 Install demand for electromagnetic on-off device

4.5 Noise filter installation instructions

(1) To use strictly as per the rated value; filter metal casing grounding must connect reliably to assemble cabinet metal grounding in large scale and it required good conductive continuity. Otherwise, it may cause electric shock and influence the EMC effect seriously.

(2) Filter grounding terminal and inverter (⊕) terminal must connect to the same common earth grounding, otherwise it will influence the EMC effect seriously.

(3) Filter installed as close as possible to inverter power input terminal.

5 Run and operation explanation for inverter

5.1 Run of inverter

5.1.1 Running order channels

There are 3 kinds of order channel for controlling run action of the inverter such as run, stop, jog etc.

0: Keypad

Control by key , ,  on keypad (Factory default).

1: Control terminal

Use two of the control terminals X1~X5 and COM to form a two-wire control, or use three terminals X1 to X5 to form a three-wire control.

2: Communication port

Control run and stop of the inverter through upper machine or other device which can communicate with the inverter.

Choose order channel by setting function code F01.15; and also can choose by multi-function input terminal (F08.18~F08.25 choose function 49, 50, 51, 52, 53).

Also can reach switch the command channel through multi-function key  (Only parts of optional keyboards are equipped with multi-functional key).



Please make switching debugging in advance when switch the order channel to check if it can fulfill system requirement, otherwise have danger of damaging device and injuring personal.

5.1.2 Frequency-provision channel

ENA100 includes main frequency provision and assist frequency provision:

Main frequency provision:

0: Keypad analog potentiometer provision;

1: AI1 analog setting;

2: AI2 analog setting;

3: Terminal UP/DOWN adjustment provision;

4: Communication provision (Communication address: 1E01);

5, 6: Reserved

7: High speed pulse provision (X5 terminal need select the corresponding function);

8: Terminal pulse width provision (X5 terminal need select the corresponding function);

9: Terminal encoder provision(X1, X2 terminal connect to the encoder orthogonal input)

10~14: Reserved

Assist frequency provision:

0: Keypad analog potentiometer provision;

1: AI1 analog setting;

2: AI2 analog setting;

3: Terminal UP/DOWN adjustment provision;

4: Communication provision (Communication address: 1E01);

5、6: Reserved;

7: High speed pulse provision(X5 terminal need select the corresponding function);

8: Terminal pulse width provision(X5 terminal need select the corresponding function);

9: Terminal encoder provision(X3, X4 terminal connect to the encoder orthogonal input)

10: Reserved

11: Process PID given

12~20: Reserved

5.1.3 Work state

Work state of ENA100 includes of Waiting state, Running state and Parameter setting state.

Waiting state:

If there is no running command after the inverter electrified or after stop command during running state, the inverter enters into waiting state. If special conditions are met during operation, such as low frequency and low given torque, the PWM will be turned off to enter the sleep mode, and it will also enter the standby state at the moment.

Running state:

The inverter enters into running state after receiving run command.

Parameter setting state:

After receiving the parameter identification command, enter the parameter setting state, after turning into the shutdown state.

5.1.4 Run mode

ENA100 inverter have 6 kinds of run mode, Following is in turn according to their priority, jog run →closed-loop run →PLC run → multi-section speed run →swing frequency run →common run. Shown as Fig.5-1.

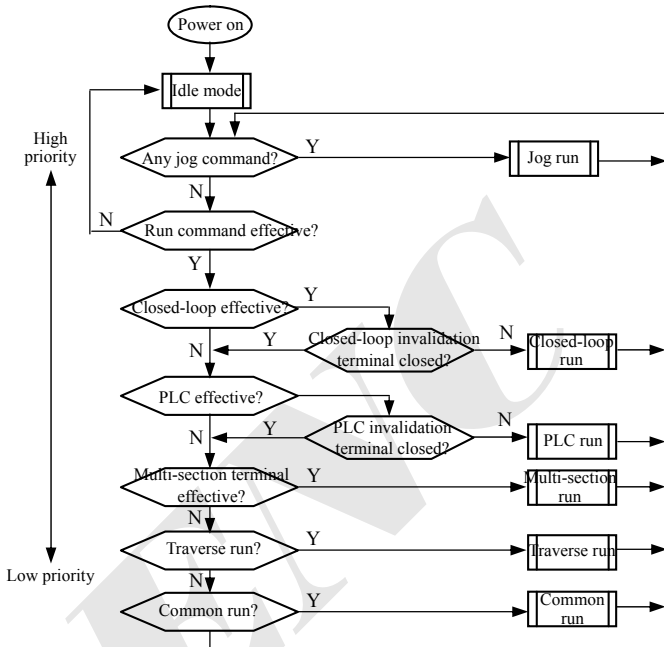



Fig.5-1 Run mode

0: Jog run

When the inverter is in the standby state, it receives a jog operation command, for example: After setting the multi-function key  of the operation keyboard to jog run through F00.15, press this key and run at the jog frequency (see function code F01.25 ~F01.29).

1: Closed-loop run

The inverter will come into closed-loop run mode when closed-loop run control effective parameter is set ($F11.00=1$ or $F12.00 \geq 1$). Namely carry on PID adjustment to specified value and feedback value (Proportion integral differential calculation, see F11 group function code) and PID adjuster output is inverter output frequency. Can make closed-loop run mode ineffective and switch to lower level run mode by

multi-function terminal (Function 31).

2: PLC run

The inverter will enter into PLC run mode and run according to run mode preset (See F10 group function code description) through setting PLC function effective parameter(F10.00 last bit≠0). Can make PLC run mode ineffective and switch to lower level run mode by multi-function terminal (Function 36).

3: Multi-section speed run

By nonzero combination of multi-function terminal (5,6,7,8,function), choose multi-section frequency 1~15 (F10.31~F10.45) to run at multi-section speed.

4: Swing frequency run

The inverter will enter into swing frequency run mode when swing frequency function effective parameter (F13.00=1) is set. Set relevant swing frequency run special parameter according to textile swing frequency craft to realize swing frequency run.

5: Common run

Common open loop run mode of general inverter.

In above 6 kinds of run mode except “jog run” the inverter can run according to kinds of frequency setting method.

5.2 Operation and use of key board

5.2.1 Keypad layout

The operating keyboard is the main unit of frequency inverter to accept commands, display parameters. Keyboard outline diagram shown in Fig.5-2.

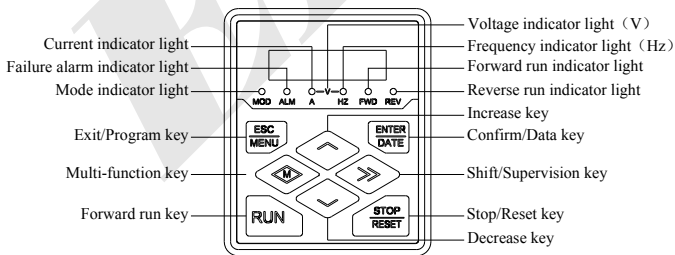









Fig.5-2 Keypad layout sketch

5.2.2 Keypad function description

There are 8 key-presses on inverter keypad, And function definition of each key is as shown in Table 5-1.

Table 5-1 Keypad function table

Key	Name	Function description
	Program/Exit	Enter into or exit programming state
	Multi-function key	The function of this key can be set by the tens place of F00.15, the default is the jog key
	Forward Run key	Enter into forward run under keypad mode
	Increasing button	To increase data or function code (to press it continuously can improve increasing speed)
	Decreasing button	To decrease data or function code (to press it continuously can improve decreasing speed)
	Function/Data	Enter into or exit programming state
	Shift/ Supervision key	Can choose modification digit of set data under editor state ; can switch display status supervision parameter under other state
	Stop/reset key	When the inverter is in normal operation, if the running command channel of the inverter is set to the effective mode of keyboard stop, press this key, the inverter will stop according to the set mode. When the inverter is in a fault state, pressing this key will reset the inverter and return to the normal stop state.

5.2.3 LED and indicator light

4 status indicator light: they are MOD(Mode):ALM(Alarm):FWD(Forward run):REV (Reverse run) from left to right on the LED: Their respective indicating meaning is as shown in table 5-2.

Table 5-2 Status indicator light description

Item		Function description		
Display function	Digital display	Display current run status parameter and set parameter		
	Status indicator light	A、Hz、V	Unit for relevant current digital displayed physical parameter (for current is A:for voltage is V:for frequency is Hz)	
		MOD	This indicator light is lit in non-supervision status and extinguished if no key pressed for a minute: then come back to supervision status	
		ALM	Alarm indicator light: indicate that the inverter is in over current or over voltage suppressing status or failure alarm status currently	
		FWD	Forward run indicator light, indicate that the inverter output forward phase order and the connected motor rotate in forward direction	The inverter work in DC brake status if FWD,REV indicator light is lit at the same time
		REV	Reverse run indicator light: indicate that the inverter output reverse phase order and the connected motor rotate in reverse direction	

5.2.4 Key board display status

ENA100 keypad display status is classified as Waiting status parameter display; Function code parameter editing status display; Malfunction alarm status display; Run status parameter display; Alarm state display in total 5 kinds of status. LED indicator light will all be lit after the inverter electrified. Then enter into set frequency display. As shown in Fig.5-3 a.

(1) Waiting parameter display status

The inverter is in waiting status and waiting status supervision parameter is displayed on keyboard: normally parameter F00.13 decide which status supervision parameter to be displayed. As shown in Fig.5-3 b, The indicator light shows the unit of the parameter.

To press  key, it can display different waiting status supervision parameter circularly: for detail please see C-00 to C-05 group supervision parameter details decide by F00.07~F00.12.

(2) Run parameter display status

The inverter enters into run status when receiving effective run command and normally parameter F00.13 decide which status supervision parameter to be displayed on the keypad. As shown in Fig.5-3 c, The indicator light shows the unit of the parameter.

To press  key can display run status supervision parameter circularly. For detail please see C-00 To C-05 group supervision parameter details decide by F00.01~F00.06.

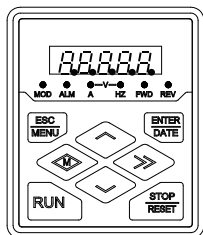

Fig.a Electrification,
display 8.8.8.8.8.

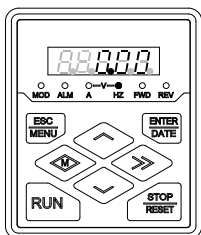

Fig.b waiting status, display
waiting status parameter

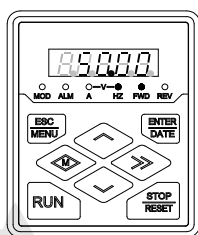

Fig.c run status: display
run status parameter

Fig.5-3 Inverter electrification: waiting: run status display

(3) Failure alarm display status

The inverter enters into failure alarm display status upon detecting failure signal and display failure code sparklingly (as shown in Fig.5-4); To press $\leftarrow \gg \rightarrow$ key can look over relative parameter after stopping running; Can press $\left[\begin{smallmatrix} \text{ESC} \\ \text{MENU} \end{smallmatrix} \right]$ key to enter into program status to see about F26 group parameter if want to search failure information. Can carry on failure restoration by $\left[\begin{smallmatrix} \text{STOP} \\ \text{RESET} \end{smallmatrix} \right]$ key: control terminal or communication command on the keypad after troubleshooting. Keep displaying failure code if failure exist continuously.

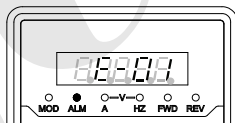

Fig.5-4



For some serious failure, such as The earthing short circuit, Inverter modules protect, over current, over voltage etc., must not carry on failure reset forcibly to make the inverter run again without failure elimination confirmed. Otherwise have danger of damaging the inverter!

(4) Function code editing status

Under waiting, run or failure alarm status, press $\left[\begin{smallmatrix} \text{ESC} \\ \text{MENU} \end{smallmatrix} \right]$ key, can enter into editing status (If user password is set, can enter into editing status after inputting the password, see also F27.00 description and Fig.5-11), and editing status is displayed according to three classes menu mode, as shown in Fig.5-5. To press $\left[\begin{smallmatrix} \text{ENTER} \\ \text{DATE} \end{smallmatrix} \right]$ key can enter into one class by one class. Under function parameter display status, to press $\left[\begin{smallmatrix} \text{ENTER} \\ \text{DATE} \end{smallmatrix} \right]$ key to carry on parameter storage operation; To press $\left[\begin{smallmatrix} \text{ESC} \\ \text{MENU} \end{smallmatrix} \right]$ key can only come back to upper class menu without storing modified parameter.

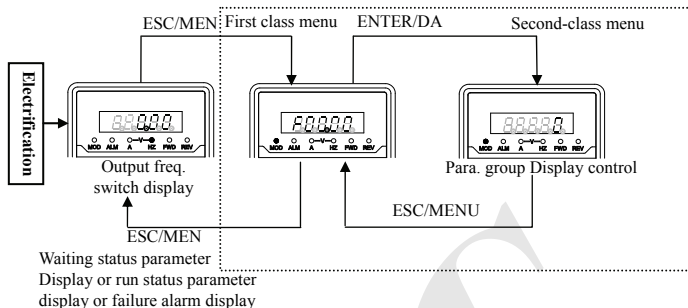
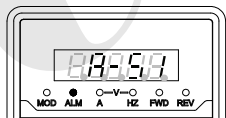

Fig.5-5 Keypad display status switching

(5) Alarm state display

When under running and standby situation: It means enter failure alarm display status upon detecting failure signal and display failure code sparkingly (Fig.5-6) Inverter keeping running state But this alarm display can't be reset button eliminated: After only find the cause of the alarm: in order to eliminate this factor Normal.



Same main/assist frequency channel

Fig.5-6 Display state

5.2.5 User Management Parameters

In order to facilitate the user parameter management: ENA100 component model parameter menu for display management. The parameters do not need to be displayed can be shielded.

(1) Method parameter setting mode display.

By setting F00.00 = 0,1,2,3,4 respectively parameter mode is set: Basic menu mode、 Menu mode Intermediate、 Advanced menu mode 、 User menu mode and Parameter check.

Basic menu	F00,F01,F02,F03,F26
Middle menu	F00,F01,F02,F03,F04,F05,F06,F07,F08,F09,F10,F11,F12,F13,F14,F15,F16,F18,F19,F26
Advance menu	F00,F01,F02,F03,F04,F05,F06,F07,F08,F09,F10,F11,F12,F13,F14,F15,F16,F17,F18,F19,F20,F21,F22,F23,F24,F25,F26,F27
User custom	F00.00 and F25 parameters group
Parameter check	Groups F00 to F25 (Only display parameters that are inconsistent with the default values.)

5.2.6 Method for operating keypad

Can carry on various operation to the inverter through keypad, for example:

(1) Status parameter display switching

After pressing key \Rightarrow , display C group status supervision parameter; after displaying one supervision parameter code for 1 second will display this parameter value automatically. Press key ENTER DATE will go back to C-00 supervision interface.

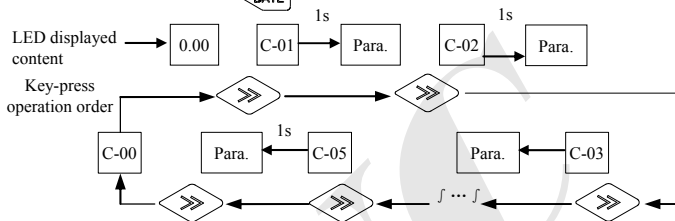

Fig.5-7 Waiting status parameter display operating example

(2) Function code parameter setting

Take function code F01.01 modified from 5.00Hz to 6.00Hz as example. Boldface in Fig.5-8 shows flickering digit.

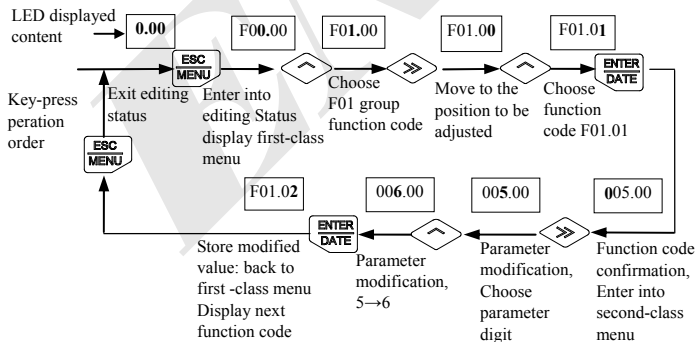

Fig.5-8 Example for parameter setting and modification

Description: under second -class menu: if the parameter has no blinking digit, this function code can't be modified, possible reasons are as follows:

1> This function code shouldn't be modified: for example actual detected

status parameter: run record parameter etc.;

2> This function code can't be modified under run status and can be changed after stopping running;

3> Parameter protected. All the function code can't be modified when function Code F00.14=1 or 2, In order to avoid wrong operation. Need to set the function code F00.14 to 0 if you want to edit function code parameter.

(3) Specified frequency adjustment for common run

Take example modifying specified frequency from 50.00Hz to 40.00Hz for F01.06=1, F01.03=0 during running for explanation.

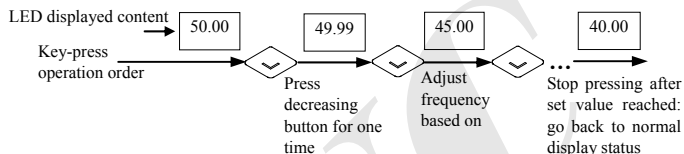

Fig.5-9 Set frequency adjustment operation example

(4) Jog run operation

For example: keypad as current run command channel: jog run frequency 5Hz waiting status.

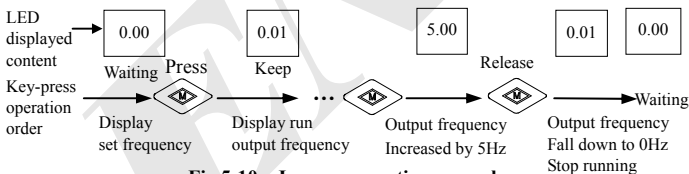

Fig.5-10 Jog run operating example

(5) Operation for entering to function code editing status after setting user password

For example: "User password" F27 is set to "12345". Boldfaced digit in Fig.5-11 shows blinking bit.

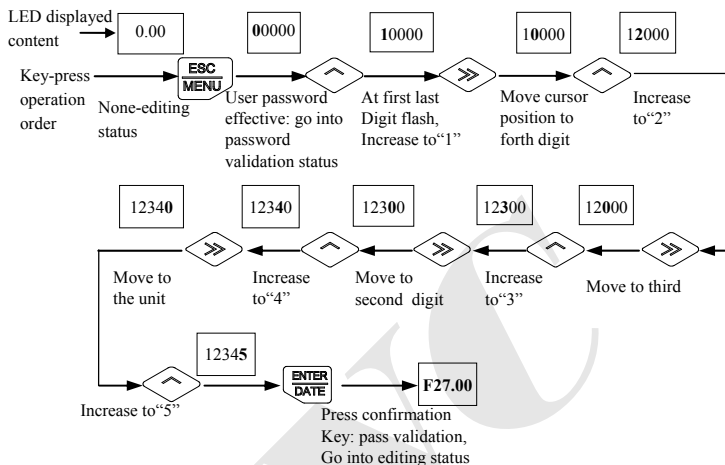

Fig.5-11 Inputting password to go into function code operation

(6) See about failure parameter under failure status:

If press $\diamond \gg$ key under failure status the user can quickly locate to the F26 group function code parameter. Press $\diamond \gg$ can quickly switch value between F26.04 ~ F26.10 parameters and fault alarm, easy to view the fault records.

(7) Keypad key-press locking operation

Under monitoring situation, To press ENTER DATE for 5s, the keyboard will display 'LOCH1', now the buttons on the keyboard are under locked. The detailed locked situation is decided by the value of hundred unit of F00.14.

(8) Keypad key-press unlocking operation

Under keypad-locked situation, press ESC MENU key for more than 5s to unlock the keypad.

5.3 Inverter electrification

5.3.1 Check before electrification

Please carry on wiring based on operation requirement provided in "inverter wiring" of this Service manual.

5.3.2 First electrification

Close input side AC power supply switch after correct wiring and power supply confirmed: electrify the inverter and keypad LED display “8.8.8.8.8”, contactor closed normally: LED displayed set frequency shows that electrification is finished. First electrification operation process is shown as Fig.5-12:

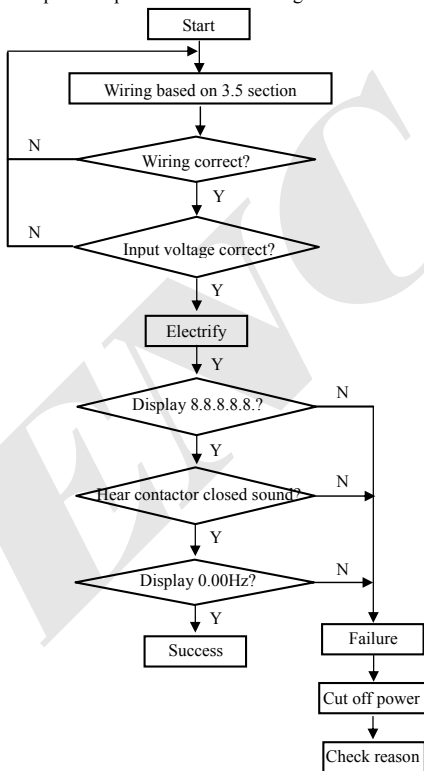

Fig.5-12 First electrification operation flow

6 Function parameter schedule graph

6.1 Symbol description

- × ---- Parameter can't be changed in process of running
- ---- Parameter can be changed in process of running
- * ---- Read-only parameter, unmodifiable

6.2 Function parameter schedule graph

F00-System Parameter Group					
Function code	Name	Set range	Min. unit	Factory Default	Modification
F00.00	Parameter group display control	0: Basic list mode (Only display F00~F03 basic control parameter group and F26 fault record parameter group). 1: Middle list mode (Display all parameter except for extension: virtual and reserve parameter group). 2: Senior list mode (All parameter display). 3: User list mode (Display parameter defined by user: and monitor parameter: F00.00 display all the time). 4: Parameter check mode (Groups F00 to F25, only display parameters that are inconsistent with the default values).	1	2	○
F00.01	C-00 display parameter selection when operation	0: Main setup frequency (0.01Hz) 1: Auxiliary setup frequency (0.01Hz) 2: Setup frequency (0.01Hz) 3: Output synchronization frequency (0.01Hz) 4: Output current (0.1A) (11KW and below display 0.01A) 5: Output voltage (1V) 6: DC busbar voltage (0.1V) 7: Motor speed (1 circle/min) 8: Motor line velocity (1 circle/min) 9: Inverter temperature (1°C) 10: Run time already this time (0.1min) 11: Current accumulate run time (1h) 12: Current accumulate power-on time (1h) 13: Inverter status	1	51	○

		14: Input terminal status 15: Output terminal status 16,17: Reserved 18: Communication virtual input terminal status 19: Internal virtual input node status 20: Analog input AI1 (After calibration) (0.01V) 21: Analog input AI2 (After checkout) (0.01V/0.01mA) 22,23: Reserved 24: Analog AO1 output (After checkout) (0.01V/0.01mA) 25~27: Reserved 28: External pulse input frequency (Before correction) (1Hz) 29: Reserved 30: Process PID provide (0.01V) 31: Process PID feedback (0.01V) 32: Process PID deviation (0.01V) 33: Process PID output (0.01Hz) 34: Simple PLC current segment No. 35: External multi-speed current segment No. 36: Constant pressure water supply provide pressure (0.001Mpa) 37: Constant pressure water supply feedback pressure (0.001Mpa) 38: Constant pressure water supply relay status 39: Current length (m/cm/mm) 40: Accumulate length (m/cm/mm) 41: Current internal count value 42: Current internal time value (0.1s) 43: Run command setup channel (0: Keyboard 1: Terminal 2: Communication) 44: Main frequency provide channel 45: Auxiliary frequency provide channel 46: Rated current (0.1A) 47: Rated voltage (1V) 48: Rated power (0.1KW) 49: Electric torque limit (0.1% Rated torque of motor) 50: Brake torque limit (0.1% motor rated			
--	--	---	--	--	--















6 Function parameter schedule graph

		torque) 51: Frequency after Acc/Dec (0.01Hz) 52: Motor rotor frequency (0.01Hz) 53: Current given torque (Percentage relative to rated torque, with direction) 54: Current output torque (Percentage relative to rated torque, with direction) 55: Torque current at present (0.1A) 56: Glux current at present (0.1A) 57: Setting motor rotate speed (r/min) 58: Output power (active power)(0.1KW) 59: The low digit of Total power consumption (1kwh) 60: The high digit of Total power consumption (1 represents 10000 kwh) 61、 62: Reserved 63: Basic PLC total setting time (1s or 1min) 64: Basic PLC elapsed time (1s or 1min) 65: Basic PLC remaining running time (1s or 1min) 66: The dedicated display mode for constant pressure water supply (SP-PV) (kg/cm ²) 67~75: Reserved			
F00.02	C-01 display Parameter selection when operation	Same as above	1	2	○
F00.03	C-02 display parameter selection when operation	Same as above	1	4	○
F00.04	C-03 display parameter selection when operation	Same as above	1	5	○
F00.05	C-04 display parameter selection when operation	Same as above	1	6	○
F00.06	C-05 display parameter selection when operation	Same as above	1	9	○

6 Function parameter schedule graph

F00.07	C-00 display parameter selection when stop	Same as above	1	2	○
F00.08	C-01 display parameter selection when stop	Same as above	1	6	○
F00.09	C-02 display parameter selection when stop	Same as above	1	48	○
F00.10	C-03 display parameter selection when stop	Same as above	1	14	○
F00.11	C-04 display parameter selection when stop	Same as above	1	20	○
F00.12	C-05 display parameter selection when stop	Same as above	1	9	○
F00.13	Power-on fault monitor parameter selection	0~5 (0~5 corresponds to C-00 to C-05)	1	0	○
F00.14	Parameter operation control	<p>Units digit: Parameter modification operations</p> <p>0: All parameters are allowed to be modified</p> <p>1: Except current parameter, all other parameters are not allowed to modify the</p> <p>2: Except F01.01, F01.04 and current parameter, all other parameters are not allowed to be modified</p> <p>Tens digit: Reset to factory defaults</p> <p>0: No action.</p> <p>1: All parameters return to default. (Not include fault record parameter group (F26 Group) parameter).</p> <p>2: Except for motor parameter: All parameters return to default. (Not include F15 and F26 group parameter).</p>	1	500	×

6 Function parameter schedule graph

		<p>3: Extension parameter return to default. (Only F21~F24 group parameter return to default).</p> <p>4: Virtual parameter return to default. (only F20 group parameter return to default).</p> <p>5: Fault record return to default.(only fault record parameter group (F26 group) parameter return to default)</p> <p>Hundreds digit: Key operation</p> <p>0: All locked</p> <p>1: Except  button: The others locked</p> <p>2: Except  ,  button: The others locked</p> <p>3: Except ,  button: The others locked</p> <p>4: Except ,  button: The others locked</p> <p>5: Invalid lock</p>			
F00.15	Button function selection	<p>Units digit: Panel  button selection (Only optional keyboard is effective)</p> <p>0: Reversal command action button</p> <p>1: Jog action button</p> <p>Tens digit:  multi-function button function selection (Keyboard support required)</p> <p>0: Invalid.</p> <p>1: Jog run.</p> <p>2: For/Rev switching.</p> <p>3: Free stop.</p> <p>4: Switching to run command provide mode as the set up order of F00.16.</p> <p>5: Forward/Reverse Torque Switching</p> <p>6: Reserved command key</p> <p>7~9: Reserved</p> <p>Hundreds digit: Terminal run command control</p> <p>0: Keyboard  button invalid</p> <p>1: Keyboard  button valid</p> <p>Thousands digit: Communication run command control</p> <p>0: Keyboard  button invalid</p> <p>1: Keyboard  button valid</p>	1	0011	○

6 Function parameter schedule graph

F00.16	Multi-function key run command channel switching order selection	0: Keyboard control→ terminal control→ communication control 1: Keyboard control←→Terminal control 2: Keyboard control←→Communication control 3: Terminal control←→Communication control	1	0	○
F00.17	Motor speed display coefficient	0.1~999.9%	0.1%	100.0 %	○
F00.18	Line velocity display coefficient	0.1~999.9%	0.1%	1.0%	○
F00.19	Reserved				
F00.20	Analog input terminal configuration	Units digit: Reserved Tens digit: AI2 configuration 0: 0~10V input 1: 0~20mA input 2: 4~20mA input Hundreds and Thousands digit: Reserved	1	0000	×
F00.21	Analog output terminal configuration	Units digit: AO1 configuration 0: 0~10V output 1: 0~20mA output Tens, Hundreds and thousands digit: Reserved	1	0000	×
F00.22	Y output terminal configuration	Units digit ~ Hundreds digit: Reserved Thousands digit: Y2 output configuration 0: Open collector output 1: DO output	1	0000	×
F00.23	G/P type setup	0: Heavy load 1: Light load	1	0	×
F00.24	Motor control mode	0: V/F control (Object to torque control) 1: Speed less sensor vector control	1	0	×
F00.25	Reserved				
F00.26	Busbar voltage adjustment coefficient	0.900~1.100	1	1.000	○
F00.27	Parameters copying and Language selection	Units digit: Reserved Tens digit: Parameter upload and download (Only external keyboard is valid) 0: Inaction 1: Parameter upload 2: Parameter download 1 (Without motor parameter) 3: Parameter download 2 (With motor parameter)	1	00	×
F00.28	Output power display	20%~300%	1%	100%	○

6 Function parameter schedule graph

F00.29 ~ F00.60	Reserved				
F00.61	The fault type of the current fault	0~65535	1	0	*
F00.62 ~ F00.70	Reserved				

F01-Basic Run Function Parameter Group					
Function Code	Name	Set Range	Min. Unit	Factory Default	Modification
F01.00	Main frequency input channel selection	0: Operation keyboard digital setup 1: AI1 analog setup 2: AI2 analog setup 3: Terminal UP/DOWN adjusting setup 4: Communication provide (Communication address: 1E01). 5,6: Reserved 7: High speed pulse setup (X5 terminal need choose the suitable function) 8: Terminal pulse setup (X5 terminal need choose the suitable function) 9: Terminal encoder setup (X1, X2 connect the encoder punctuation input) 10~14: Reserved	1	0	○
F01.01	Main frequency digital setup	0.00Hz~Upper limit frequency	0.01 Hz	50.00Hz	○
F01.02	Main frequency digital control	Only when parameter F01.00=0,3,4 valid. Units digit: Power down reserve setup 0: Main frequency power down reserve. 1: Main frequency power down no reserve. Tens digit: Halt reserve setup 0: Halt main frequency hold 1: Halt main frequency recovery F01.01 Hundreds digit: Set of communication presetting frequency dimension 0: Preset of absolute frequency mode (Preset 5000 represent 50.00Hz). 1: Preset 10000 represent upper limit frequency (F01.11).	1	000	○

6 Function parameter schedule graph

F01.03	Auxiliary frequency input channel select	0: Operation keyboard digital setup 1: AI1 analog setup 2: AI2 analog setup 3: Terminal UP/DOWN adjusting setup 4: Communication provide (Communication address: 1E01). 5,6: Reserved 7: High speed pulse setup X5 terminal need choose the suitable function) 8: Terminal pulse setup(X5 terminal need choose the suitable function) 9: Terminal encoder setup(X3, X4 connect the encoder punctuation input) 10: Reserved 11: Process PID Setting 12~20: Reserved	1	20	○
F01.04	Auxiliary frequency digital setup	0.00Hz~upper limit frequency	0.01 Hz	0.00Hz	○
F01.05	Auxiliary frequency digital control	Units digit: Power down reserve setup 0: Auxiliary frequency power down reserve. 1: Auxiliary frequency power down no reserve. Tens digit: Halt reserve setup 0: Halt auxiliary frequency hold. 1: Halt auxiliary frequency recovery parameter F01.04	1	11	○
F01.06	Main and auxiliary provide calculating setup	0: Main frequency (Complex frequency of current is main frequency). 1: Auxiliary frequency (Complex frequency of current is auxiliary frequency). 2: Plus (Polarity oppose of complex and main Frequency, Complex frequency is zero). 3: Minus (Polarity oppose of complex and auxiliary Frequency, Complex frequency is zero). 4: Multiplication (Polarity opposed of main and auxiliary frequency: Complex frequency is zero). 5: Max (The max frequency of main and auxiliary absolute value). 6: Min (The min frequency of main and	1	0	○

6 Function parameter schedule graph

		auxiliary absolute value). 7: Selection no-zero value (Auxiliary is not negative, main frequency prior; Auxiliary is negative, Complex frequency is zero). 8: Main frequency×Auxiliary frequency ×2/F01.11 (Polarity opposed of main and auxiliary frequency ,complex frequency is zero)			
F01.07	Auxiliary frequency provide coefficient	0.00~10.00	0.01	1.00	○
F01.08	Coefficient after complex of main and auxiliary frequency	0.00~10.00	0.01	1.00	○
F01.09	Auxiliary frequency range selection	0: Relative upper limit frequency. 1: Relative main frequency.	1	0	○
F01.10	Auxiliary frequency source scope	0.00~1.00	0.01	1.00	○
F01.11	Upper limit frequency	Low limit frequency~600.00Hz	0.01 Hz	50.00Hz	×
F01.12	Low limit frequency	0.00Hz~upper limit frequency	0.01 Hz	0.40Hz	×
F01.13	Low limit frequency run mode	0: As low limit frequency run. 1: As setting frequency run. 2: As zero frequency run. 3: Sleep, PWM clocked at sleep mode.	1	2	×
F01.14	Sleep run hysteresis frequency	0.01Hz~upper limit frequency (This function can be used to finish the sleep mode function, realizing energy-saving operation process, and the hysteresis width can avoid inverter starting frequently in threshold)	0.01 Hz	0.01Hz	○
F01.15	Run command channel selection	0: Operation keyboard run control. 1: Terminal run command control 2: Communication run command control.	1	0	○
F01.16	Run direction setup	Units digit: Keyboard command For/Rev setup (Only valid to keyboard inching command) 0: Forward 1: Reverse	1	1000	○

6 Function parameter schedule graph

		<p>Tens digit: For/Rev forbid (Suitable for all command channel, Not include inching function) 0: For/Rev available. 1: Reverse not available (Imposing on reverse, stop as the halt mode). 2: Forward not available (Imposing on forward, stop as the halt mode) Hundreds digit: Reverse running direction (Only valid for keyboard and communication channel) 0: Invalid 1: Valid Thousands digit: Terminal multi-section speed acceleration and deceleration time control 0: Respectively, corresponding to acceleration and deceleration 1~15 1: Determined by F01.17 and F01.18</p>			
F01.17	Acceleration time 1	1~60000 (Acceleration time is interval accelerate from zero frequency to upper limit frequency)	1	Base on motor type	○
F01.18	Deceleration time 1	1~60000 (Deceleration time is the interval decelerate from upper limit frequency to zero frequency)	1	Base on motor type	○
F01.19	Acc/Dec time unit	0: 0.01s 1: 0.1s 2: 1s	1	1	×
F01.20	Acc/Dec mode selection	0: Line Acc/Dec mode. 1: S curve Acc/Dec mode.	1	0	×
F01.21	S curve acceleration initiation segment time	10.0%~50.0% (Acceleration/deceleration time) S curve deceleration start time+ S curve deceleration raise time ≤90%)	0.1%	20.0%	○
F01.22	S curve acceleration up segment time	10.0%~70.0% (Acceleration/deceleration time) S curve acceleration start time+ S curve acceleration raise time ≤90%)	0.1%	60.0%	○
F01.23	S curve deceleration initiation segment time	10.0%~50.0% (Acceleration/deceleration time) S curve acceleration start time+ S curve acceleration raise time ≤90%)	0.1%	20.0%	○
F01.24	S curve deceleration up segment time	10.0%~70.0% (Acceleration/deceleration time) S curve acceleration start time+ S curve acceleration raise time ≤90%)	0.1%	60.0%	○
F01.25	Keyboard jog	0.00Hz~upper limit frequency	0.01	5.00Hz	○

6 Function parameter schedule graph

	run frequency		Hz		
F01.26	Terminal jog run frequency	0.00Hz~upper limit frequency	0.01 Hz	5.00Hz	○
F01.27	Jog interval time	0.0~100.0s	0.1s	0.0s	○
F01.28	Jog acceleration time	0.1~6000.0s	0.1s	20.0s	○
F01.29	Jog deceleration time	0.1~6000.0s	0.1s	20.0s	○
F01.30	Reserved				
F01.31	Reserved				

F02-Start, Stop, Forward/Reverse, Brake function parameter group

Function Code	Name	Set Range	Min. Unit	Factory Default	Modification
F02.00	Start running mode	0: Start from starting frequency 1: First brake and then start from starting frequency 2: Speed tracking start (Valid for asynchronous motor)	1	0	×
F02.01	Starting delay time	0.0 ~ 60.0s	0.1s	0.0s	×
F02.02	Starting frequency	0.0 ~10.00Hz	0.01Hz	0.00Hz	×
F02.03	Starting frequency duration time	0.0 ~ 60.0s	0.1s	0.0s	×
F02.04	DC braking current when starting	0.0 ~100.0% (Motor rated current)	0.1%	30.0%	×
F02.05	DC braking time when starting	0.0~30.0s	0.1s	0.0s	×
F02.06	Speed track starting frequency selection	0: Current setting frequency. 1: Running frequency before power down. 2: Speed track auxiliary starting frequency.	1	2	×
F02.07	Speed track auxiliary starting frequency	0.00Hz ~ upper limit frequency	0.01Hz	30.00 Hz	×
F02.08	Speed track starting waiting time	0.00~10.00s	0.01s	0.10s	×
F02.09	Speed track	1~20	1	2	×

6 Function parameter schedule graph

	current control coefficient				
F02.10	Speed track searching speed time	0.1~30.0 (V/F control unit is 1 second; SVC control unit is 0.1 second)	0.1	4.0	×
F02.11	Stop mode	0: Deceleration stop. 1: Free stop 2: Deceleration + DC braking stop.	1	0	○
F02.12	Deceleration stop holding frequency	0.00~upper limit frequency (This parameter is only valid for stop mode 0.)	0.01Hz	0.00Hz	×
F02.13	Deceleration stop holding time	0.00~10.00s	0.01s	0.00s	×
F02.14	Stop DC braking starting frequency	0.00~15.00Hz	0.01Hz	0.50Hz	×
F02.15	Stop DC braking waiting time	0.00~30.00s	0.01s	0.00s	×
F02.16	Stop DC braking current	0.0~100.0% (Motor rated current)	0.1%	0.0%	×
F02.17	Stop DC braking time	0.0~30.0s	0.1s	0.0s	×
F02.18	Stop auxiliary braking current	0.0~100.0% (Motor rated current)	0.1%	0.0%	×
F02.19	Stop auxiliary braking time	0.0~100.0s	0.1s	0.0s	×
F02.20	Forward/Reverse dead zone time	0.0~3600.0s	0.1s	0.0s	×
F02.21	Forward/Reverse switching mode	0: Over zero switchover 1: Over starting frequency switchover	1	0	×
F02.22	Energy consumption braking selection	0: No energy consumption braking 1: Energy consumption braking 1 (No braking while halting). 2: Energy consumption braking 2 (Braking while halting).	1	0	○
F02.23	Energy consumption braking voltage	100.0~145.0% (Rated busbar voltage)	0.1%	125.0%	○
F02.24	Energy consumption braking use rate	0.0~100.0%	0.1%	100.0%	○
F02.25	Encryption time	0~65535h	1	0	○
F02.26	Vector control shutdown frequency	0.20Hz~5.00Hz	0.01	0.40Hz	○

6 Function parameter schedule graph

F03-V/F control parameter group					
Function Code	Name	Set Range	Min. Unit	Factory Default	Modification
F03.00	V/F curve set	0: Constant torque curve 1: Decreasing torque curve 1 (1.2 power) 2: Decreasing torque curve 2 (1.7 power) 3: Decreasing torque curve 3 (2.0 power) 4: User self-defined setting V/F curve (Confirmed by F03.04~F03.11) 5: V/F Separation control (voltage channel is determined by F18.22)	1	0	×
F03.01	Torque boost mode	0: Manual boost. 1: Auto torque boost	1	0	○
F03.02	Torque boost	0.0~12.0%	0.1%	Base on motor type	○
F03.03	Torque boost cut-off frequency	0.0~100.0% (Motor rated frequency)	0.1%	100.0 %	○
F03.04	V/F frequency value 0	0.00~V/F frequency value 1	0.01Hz	10.00 Hz	×
F03.05	V/F voltage value 0	0.00~V/F voltage value 1	0.01%	20.00 %	×
F03.06	V/F frequency value 1	V/F frequency value 0~V/F frequency value 2	0.01Hz	20.00 Hz	×
F03.07	V/F voltage value 1	V/F voltage value 0~V/F voltage value 2	0.01%	40.00 %	×
F03.08	V/F frequency value 2	V/F frequency value 1~V/F frequency value 3	0.01Hz	25.00 Hz	×
F03.09	V/F voltage value 2	V/F voltage value 1~V/F voltage value 3	0.01%	50.00 %	×
F03.10	V/F frequency value 3	V/F frequency value 2~upper limit frequency	0.01Hz	40.00 Hz	×
F03.11	V/F voltage value 3	V/F voltage value 2~100.00% (Motor rated voltage)	0.01%	80.00 %	×
F03.12	V/F oscillation suppression factor	0~255	1	10	○

F04-Auxiliary running parameter group					
Function Code	Name	Set Range	Min. Unit	Factory Default	Modification

6 Function parameter schedule graph

F04.00	Jump freq. 1	0.00Hz~upper limit frequency	0.01Hz	0.00Hz	×
F04.01	Jump freq. 1 range	0.00Hz~upper limit frequency	0.01Hz	0.00Hz	×
F04.02	Jump freq. 2	0.00Hz~upper limit frequency	0.01Hz	0.00Hz	×
F04.03	Jump freq. 2 range	0.00Hz~upper limit frequency	0.01Hz	0.00Hz	×
F04.04	Jump freq. 3	0.00Hz~upper limit frequency	0.01Hz	0.00Hz	×
F04.05	Jump freq. 3 range	0.00Hz~upper limit frequency	0.01Hz	0.00Hz	×
F04.06	Slip freq. gain	0.0~300.0%	0.1%	0.0%	×
F04.07	Slip compensation limit	0.0~250.0%	0.1%	100.0%	×
F04.08	Slip compensation time constant	0.1~25.0s	0.1s	2.0s	×
F04.09	Carrier freq.	0.5~16.0K	0.1K	Based on motor type	○
F04.10	PWM optimized adjustment	Units digit: Carrier freq. is adjusted automatically according to temperature 0: Banned. 1: Allowed. Tens digit: Low speed carrier freq. limit mode 0: No limit. 1: Limit. Hundreds digit: Carrier wave modulation system 0: 3 phase modulation. 1: 2 phase and 3 phase modulation. Thousands digit: Reserved	1	0010	×
F04.11	AVR function	0: No action 1: Action all the time 2: No action only during deceleration	1	2	×
F04.12	Random PWM adjustment depth	0: Random PWM is invalid 1~10: PWM carrier frequency random depth (VF control mode is valid)	1	0	○
F04.13	Automatic energy-saving operation	0: No action 1: Action	1	0	×
F04.14	Acceleration time 2 and 1 switchover frequency	0.00Hz~upper limit frequency	0.01Hz	0.00Hz	×
F04.15	Deceleration time 2 and 1 switchover frequency	0.00Hz~upper limit frequency	0.01Hz	0.00Hz	×
F04.16	Acceleration time 2	1~60000	1	200	○

6 Function parameter schedule graph

F04.17	Deceleration time 2	1~60000	1	200	○
F04.18	Acceleration time 3	1~60000	1	200	○
F04.19	Deceleration time 3	1~60000	1	200	○
F04.20	Acceleration time 4	1~60000	1	200	○
F04.21	Deceleration time 4	1~60000	1	200	○
F04.22	Acceleration time 5	1~60000	1	200	○
F04.23	Deceleration time 5	1~60000	1	200	○
F04.24	Acceleration time 6	1~60000	1	200	○
F04.25	Deceleration time 6	1~60000	1	200	○
F04.26	Acceleration time 7	1~60000	1	200	○
F04.27	Deceleration time 7	1~60000	1	200	○
F04.28	Acceleration time 8	1~60000	1	200	○
F04.29	Deceleration time 8	1~60000	1	200	○
F04.30	Acceleration time 9	1~60000	1	200	○
F04.31	Deceleration time 9	1~60000	1	200	○
F04.32	Acceleration time 10	1~60000	1	200	○
F04.33	Deceleration time 10	1~60000	1	200	○
F04.34	Acceleration time 11	1~60000	1	200	○
F04.35	Deceleration time 11	1~60000	1	200	○
F04.36	Acceleration time 12	1~60000	1	200	○
F04.37	Deceleration time 12	1~60000	1	200	○
F04.38	Acceleration time 13	1~60000	1	200	○
F04.39	Deceleration time 13	1~60000	1	200	○
F04.40	Acceleration time 14	1~60000	1	200	○
F04.41	Deceleration time 14	1~60000	1	200	○
F04.42	Acceleration time 15	1~60000	1	200	○
F04.43	Deceleration time 15	1~60000	1	200	○
F04.44	Reserved				
~					
F04.47					

F05-Terminal correlative function parameter group

Function Code	Name	Set Range	Min. Unit	Factory Default	Modification
F05.00	Protocol selection	0: Modbus protocol. 1~4: Reserved 5: Free protocol 1.(Can realize all the function parameter modification of ENA100) 6: Free protocol 2.(Can realize part of the function parameter modification of ENA100)	1	0	×

6 Function parameter schedule graph

F05.01	Baud rate configuration	Units digit: Free protocol and Modbus Baud rate selection 0-3: Reserved 4: 4800BPS 5: 9600BPS 6: 19200BPS 7: 38400BPS 8: 57600BPS 9: 115200BPS Tens, Hundreds digit: Reserved	1	005	×
F05.02	Data format	Units digit: Free protocol and Modbus protocol data format 0: 1-8-1 format, no parity, RTU 1: 1-8-1 format, even parity, RTU 2: 1-8-1 format, odd parity, RTU 3: 1-7-1 format, no parity, ASCII 4: 1-7-1 format, even parity, ASCII 5: 1-7-1 format, odd parity, ASCII Tens digit: Reserved Hundreds digit: Modbus agreement or free protocol response selection 0: Respond mainframe demand, and respond data package 1: Respond mainframe demand without response (Response when write parameter) 2: Respond mainframe demand without response (Without response when write parameter) Thousands digit: Communication Sets power down reserve setup 0: No reserve 1: Reserve	1	0000	×
F05.03	Local address	0~247, This function code is used to identify inverter's address: among which 0 is broadcast address. When setting broadcast address: it can only receive and execute upper computer broadcast command: while cannot respond to upper computer.	1	1	×
F05.04	Communication overtime checkout time	0.0~1000.0s	0.1s	0.0s	○
F05.05	Communication error checkout time	0.0~1000.0s	0.1s	0.0s	○
F05.06	Local response delay time	0~200ms (Modbus effective)	1ms	2ms	○
F05.07	Main & sub inverter	0~500%	1%	100%	○

6 Function parameter schedule graph

	communication frequency setting percentage				
F05.08	Communication virtual input terminal enabled	00~FFH Bit0: CX1 virtual input terminal enabled 0: Forbidden 1: Enabled Bit1: CX2 virtual input terminal enabled 0: Forbidden 1: Enabled Bit2: CX3 virtual input terminal enabled 0: Forbidden 1: Enabled Bit3: CX4 virtual input terminal enabled 0: Forbidden 1: Enabled Bit4: CX5 virtual input terminal enabled 0: Forbidden 1: Enabled Bit5: CX6 virtual input terminal enabled 0: Forbidden 1: Enabled Bit6: CX7 virtual input terminal enabled 0: Forbidden 1: Enabled Bit7: CX8 virtual input terminal enabled 0: Forbidden 1: Enabled	1	00H	○
F05.09	Communication virtual input terminal joining node	0: Independent node. 1: Terminal node.	1	0	○
F05.10	Communication virtual terminal CX1 function	0~90	1	0	○
F05.11	Communication virtual terminal CX2 function	0~90	1	0	○
F05.12	Communication virtual terminal CX3 function	0~90	1	0	○
F05.13	Communication virtual terminal CX4 function	0~90	1	0	○
F05.14	Communication virtual terminal CX5 function	0~90	1	0	○
F05.15	Communication virtual terminal CX6 function	0~90	1	0	○
F05.16	Communication virtual terminal	0~90	1	0	○

6 Function parameter schedule graph

	CX7 function				
F05.17	Communication virtual terminal CX8 function	0~90	1	0	○
F05.18	Input mapping application parameter 1	F00.00~F26.xx	0.01	25.00	○
F05.19	Input mapping application parameter 2	F00.00~F26.xx	0.01	25.00	○
F05.20	Input mapping application parameter 3	F00.00~F26.xx	0.01	25.00	○
F05.21	Input mapping application parameter 4	F00.00~F26.xx	0.01	25.00	○
F05.22	Input mapping application parameter 5	F00.00~F26.xx	0.01	25.00	○
F05.23	Input mapping application parameter 6	F00.00~F26.xx	0.01	25.00	○
F05.24	Input mapping application parameter 7	F00.00~F26.xx	0.01	25.00	○
F05.25	Input mapping application parameter 8	F00.00~F26.xx	0.01	25.00	○
F05.26	Input mapping application parameter 9	F00.00~F26.xx	0.01	25.00	○
F05.27	Input mapping application parameter 10	F00.00~F26.xx	0.01	25.00	○
F05.28 ~ F05.39	Reserved				

F06-Setting curve parameter group

Function Code	Name	Set Range	Min. Unit	Factory Default	Modification
F06.00	Setting curve selection	Units digit: A11 curve selection 0: Curve 1 1: Curve 2 2: Curve 3	1	0000	○

6 Function parameter schedule graph

		Tens digit: AI2 curve selection: The same as Units digit Hundred digit: Rapid pulse curve selection: The same as Units digit Thousands digit: Pulse width setting curve selection: The same as Units digit			
F06.01	Curve 1 min. setting	0.0%~Curve 1 inflexion setting	0.1%	0.0%	○
F06.02	Corresponding physical quantity of curve 1 min. setting	0.0~100.0%	0.1%	0.0%	○
F06.03	Curve 1 inflexion setting	Curve 1 min. setting ~ Curve 1 Max. setting	0.1%	50.0%	○
F06.04	Corresponding physical quantity of curve 1 inflexion setting	0.0~100.0%	0.1%	50.0%	○
F06.05	Curve 1 Max. setting	Curve 1 inflexion setting ~ 100.0%, 100.0% is corresponding to 5V Input AD terminal	0.1%	100.0%	○
F06.06	Corresponding physical quantity of curve 1 Max. setting	0.0~100.0%	0.1%	100.0%	○
F06.07	Curve 2 min. setting	0.0% ~ Curve 2 inflexion setting	0.1%	0.0%	○
F06.08	Corresponding physical quantity of curve 2 min. setting	0.0~100.0%	0.1%	0.0%	○
F06.09	Curve 2 inflexion setting	Curve 2 min. setting ~ Curve 2 Max. setting	0.1%	50.0%	○
F06.10	Corresponding physical quantity of curve 2 inflexion setting	0.0~100.0%	0.1%	50.0%	○
F06.11	Curve 2 Max. setting	Curve 2 inflexion setting~100.0%	0.1%	100.0%	○
F06.12	Corresponding physical quantity of curve 2 Max. setting	0.0~100.0%	0.1%	100.0%	○
F06.13	Curve 3 min. setting	0.0%~Curve 3 inflexion 1 setting	0.1%	0.0%	○
F06.14	Corresponding physical quantity of curve 3 min. setting	0.0~100.0%	0.1%	0.0%	○
F06.15	Curve 3 inflexion 1 setting	Curve 3 min. setting ~ Curve 3 inflexion 2 setting	0.1%	30.0%	○

6 Function parameter schedule graph

F06.16	Corresponding physical quantity of curve 3 inflexion 1 setting	0.0~100.0%	0.1%	30.0%	○
F06.17	Curve 3 inflexion 2 setting	Curve 3 inflexion 1 setting ~ Curve 3 Max. setting	0.1%	60.0%	○
F06.18	Corresponding physical quantity of curve 3 inflexion 2 setting	0.0~100.0%	0.1%	60.0%	○
F06.19	Curve 3 Max. setting	Curve 3 inflexion 2 setting~100.0%	0.1%	100.0%	○
F06.20	Corresponding physical quantity of curve 3 Max. setting	0.0~100.0%	0.1%	100.0%	○
F06.21	Curve lower than min. input corresponding selection	Units digit: Curve 1 setting 0: Corresponds to min. setting corresponding physical quantity. 1: 0.0% of the corresponding physical quantity. Tens digit: Curve 2 setting Same as units digit. Hundreds digit: Curve 3 setting Same as units digit. Thousands digit: Reserved Ten thousands digit: Reserved	1	00111	○

F07-Analog , Pulse input function parameter group

Function Code	Name	Set Range	Min. Unit	Factory Default	Modification
F07.00	A11 input filter time	0.000~9.999s	0.001s	0.050s	×
F07.01	A11 setting gain	0.000~9.999	0.001	1.006	○
F07.02	A11 setting bias	0.0~100.0%	0.1%	0.5%	○
F07.03	A12 input filter time	0.000~9.999s	0.001	0.050s	×
F07.04	A12 setting gain	0.000~9.999	0.001	1.003	○
F07.05	A12 setting bias	0.0~100.0%	0.1%	0.1%	○
F07.06	Analog setting bias polarity	Units digit: A11 setting bias polarity 0: Positive polarity. 1: Negative polarity. Tens digit: A12 setting bias polarity 0: Positive polarity. 1: Negative polarity.	1	01	○
F07.07	Pulse input filter time	0.000~9.999s	0.001	0.000s	×

6 Function parameter schedule graph

F07.08	Pulse input gain	0.000~9.999	0.001	1.000	○
F07.09	Pulse input Max. frequency	0.01~20.00KHz	0.01 KHz	10.00 KHz	○
F07.10	Pulse width input filter time	0.000~9.999s	0.001s	0.000s	×
F07.11	Pulse width input gain	0.000~9.999	0.001	1.000	○
F07.12	Pulse width input logic setting.	0: Positive logic 1: Negative logic	1	0	○
F07.13	Max pulse input width	1.0~999.9ms	0.1ms	100.0 ms	○
F07.14	Analog input disconnection detection threshold	0.0%~100.0%	0.1%	10.0%	○
F07.15	Analog input disconnection detection time	0.0~500.0s	0.1s	3.0s	○
F07.16	Analog disconnection protection option	Units digit: Disconnection detection channel choice 0: Invalid 1: AI1 2: AI2 Tens digit: Disconnection protection way 0: Stop according to stop mode 1: Fault, free stop 2: Continue operation	1	10	○
F07.17 ~ F07.19	Reserved				

F08-On-off input function parameter group

Function Code	Name	Set Range	Min. Unit	Factory Default	Modification
F08.00	Input terminal positive and negative logic setting	0000~FFFF	1	0000	○
F08.01	Input terminal filter time	0.000~1.000s	0.001s	0.010s	○
F08.02	X1 Input terminal closed time	0.00~99.99s	0.01s	0.00s	○
F08.03	X1 Input terminal opened time	0.00~99.99s	0.01s	0.00s	○
F08.04	X2 Input terminal	0.00~99.99s	0.01s	0.00s	○

6 Function parameter schedule graph

	closed time				
F08.05	X2 Input terminal opened time	0.00~99.99s	0.01s	0.00s	○
F08.06	X3 Input terminal closed time	0.00~99.99s	0.01s	0.00s	○
F08.07	X3 Input terminal opened time	0.00~99.99s	0.01s	0.00s	○
F08.08	X4 Input terminal closed time	0.00~99.99s	0.01s	0.00s	○
F08.09	X4 Input terminal opened time	0.00~99.99s	0.01s	0.00s	○
F08.10	A11 input terminal closed time	0.00~99.99s	0.01s	0.00s	○
F08.11	A11 input terminal opened time	0.00~99.99s	0.01s	0.00s	○
F08.12	A12 input terminal closed time	0.00~99.99s	0.01s	0.00s	○
F08.13	A12 input terminal opened time	0.00~99.99s	0.01s	0.00s	○
F08.14	Reserved				
F08.15	Reserved				
F08.16	X5 input terminal closed time	0.00~99.99s	0.01s	0.00s	○
F08.17	X5 input terminal opened time	0.00~99.99s	0.01s	0.00s	○
F08.18	Input terminal X1 function selection	0: Leave control terminal unused 1: Forward running FWD terminal 2: Reverse running REV terminal 3: External forward jogging control 4: External reverse jogging control 5: Multi-step speed control terminal 1 6: Multi-step speed control terminal 2 7: Multi-step speed control terminal 3 8: Multi-step speed control terminal 4 9: Acceleration/Deceleration time selection terminal 1 10: Acceleration/Deceleration time selection terminal 2 11: Acceleration/Deceleration time selection terminal 3 12: Acceleration/Deceleration time selection terminal 4 13: Main and auxiliary frequency operational rule selection terminal 1	1	1	×

6 Function parameter schedule graph

		<p>14: Main and auxiliary frequency operational rule selection terminal 2</p> <p>15: Main and auxiliary frequency operational rule selection terminal 3</p> <p>16: Frequency ascending command (UP)</p> <p>17: Frequency descending command (DOWN)</p> <p>18: Frequency ascending/Descending frequency resetting</p> <p>19: Multi-step closed loop terminal 1</p> <p>20: Multi-step closed loop terminal 2</p> <p>21: Multi-step closed loop terminal 3</p> <p>22: External equipment failure input</p> <p>23: External interruption input</p> <p>24: External resetting input</p> <p>25: Free stop input</p> <p>26: External stop instruction-Stop according to the stop mode</p> <p>27: Stop DC braking input command DB</p> <p>28: Inverter running prohibited-Stop according to the stop mode</p> <p>29: Acceleration/Deceleration prohibited command</p> <p>30: Three-wire running control</p> <p>31: Process PID invalid</p> <p>32: Process PID stop</p> <p>33: Process PID integral holding</p> <p>34: Process PID integral resetting</p> <p>35: Process PID function negation (Closed loop adjustment feature negation)</p> <p>36: Simple PLC invalid</p> <p>37: Simple PLC halted</p> <p>38: Simple PLC stop state resetting</p> <p>39: Main frequency switchover to digit (Keypad)</p> <p>40: Main frequency switchover to AI1</p> <p>41: Main frequency switchover to AI2</p> <p>42,43: Reserved</p> <p>44: Main frequency setting channel selection terminal 1</p>			
--	--	--	--	--	--

		<p>45: Main frequency setting channel selection terminal 2</p> <p>46: Main frequency setting channel selection terminal 3</p> <p>47: Main frequency setting channel selection terminal 4</p> <p>48: Auxiliary frequency reset</p> <p>49: Command switchover to panel</p> <p>50: Command switchover to terminal</p> <p>51: Command switchover to communication</p> <p>52: Running command Channel selection terminal 1</p> <p>53: Running command Channel selection terminal 2</p> <p>54: Forward prohibited command (Stop according to the stop mode: invalid for jogging command)</p> <p>55: Reverse prohibited command (Stop according to the stop mode: invalid for jogging command)</p> <p>56: Swinging frequency input</p> <p>57: Resetting state of swinging frequency</p> <p>58: Interior counter reset end</p> <p>59: Interior counter input end</p> <p>60: Internal timer resetting</p> <p>61: Internal timer triggering</p> <p>62: Length count input</p> <p>63: Length reset</p> <p>64: Reset this operation time</p> <p>65: Speed/Torque control switching</p> <p>66~69: Reserved</p> <p>70: Water shortage signal input (Closed means water shortage)</p> <p>71: Water signal input (closed means have water)</p> <p>72~90: Reserved</p> <p>91: Pulse frequency input (X5 is valid)</p> <p>92: Pulse width PWM input (X5 is valid)</p> <p>93~96: Reserved</p>			
F08.19	Input terminal X2 function selection	Same as above	1	2	×

6 Function parameter schedule graph

F08.20	Input terminal X3 function selection	Same as above	1	0	×
F08.21	Input terminal X4 function selection	Same as above	1	0	×
F08.22	Input terminal AI1 function selection	Same as above	1	0	×
F08.23	Input terminal AI2 function selection	Same as above	1	0	×
F08.24	Reserved				
F08.25	Input terminal X5 function selection	Same as F08.18	1	0	×
F08.26	FWD/REV operating mode selection	0: Two-wire control mode 1 1: Two-wire control mode 2 2: Two-wire control mode 3 (Mono-pulse control mode) 3: Three-wire control mode 1 4: Three-wire control mode 2	1	0	×
F08.27	Set internal count value to setting	0~65535	1	0	○
F08.28	Specify internal count to setting	0~65535	1	0	○
F08.29	Internal timer timing setting	0.1~6000.0s	0.1s	60.0s	○
F08.30	Terminal pulse encoder frequency rate	0.01~10.00Hz (Only be effective by given X1,X2 encoder)	0.01Hz	1.00Hz	○
F08.31	Special function selection	Units digit: Jogging priority level selection 0: The highest priority level 1: The lowest priority level Tens digit: Keypad adjustment of display setting (Under speed control mode) 0: Display setting frequency 1: Display setting rotation speed	1	00	○
F08.32 ~ F08.35	Reserved				

F09-On-off ,analog output function parameter group

Function Code	Name	Set Range	Min. Unit	Factory Default	Modification
F09.00	The output setting of open	0: Terminal unused 1: Operation(RUN)	1	0	×

circuit collector output terminal Y1	2: Frequency inverter Forward running 3: Frequency inverter Reverse running 4: DC brake 5: Run prepare finish (Busbar voltage normal, fault free, no run forbid, Reception of run command's status) 6: Stop command indication 7: No current arrived 8: Over current arrived 9: Current1 arrived 10: Current2 arrived 11: No frequency output 12: Frequency arrival signal (FAR) 13: Frequency level detect signal 1 (FDT1) 14: Frequency level detect signal 2 (FDT2) 15: Output frequency arrival upper limit (FHL) 16: Output frequency arrival low limit (FLL) 17: Frequency 1 arrival output 18: Frequency 2 arrival output 19: Overload pre-alarm signal (OL) 20: Under voltage lockout stop (LU) 21: External fault stop (EXT) 22: Fault 23: Alarm 24: Simple PLC operation 25: Simple PLC section operation finish 26: Simple PLC circle operation finish 27: Simple PLC operation stop 28: Traverse frequency high and low limit 29: Setup length arrival 30: Internal counter final value arrival 31: Internal counter designated value arrival 32: Internal timer arrival---output 0.5s valid signal on arrival 33: Operation stop time finish 34: Operation arrival time finish 35: Setup run time arrival 36: Setup power on time arrival 37: The first pump runs with variable			
--	---	--	--	--

6 Function parameter schedule graph

		frequency 38: The second pump runs with variable frequency 39, 40: Reserved 41: Communication provision 42: Torque control speed limiting 43: Torque arriving output 44: Reserved 45: The brake logic 1 (Brake in the process of switching forward and reverse) 46: The brake logic 2 (Not brake in the process of switching Forward and reverse) 47: Frequency inverter running 1(Not jog running) 48: Analog input disconnection signal output 49: X1 Terminal closed valid 50: X2 Terminal closed valid 51: Water shortage fault output 52~60: Reserved			
F09.01	The output setting of open circuit collector output terminal Y2	Same as F09.00	1	0	×
F09.02	Reserved				
F09.03	Reserved				
F09.04	RLY1 output setting	Same as F09.00	1	22	×
F09.05	Detection amplitude of Frequency arrival (FAR)	0.00~50.00Hz	0.01Hz	5.00Hz	○
F09.06	FDT1 (Frequency level) level	0.00Hz~upper limit frequency	0.01Hz	10.00 Hz	○
F09.07	FDT1 lag	0.00~50.00Hz	0.01Hz	1.00Hz	○
F09.08	FDT2 (Frequency level) level	0.00Hz~upper limit frequency	0.01Hz	10.00 Hz	○
F09.09	FDT2 lag	0.00~50.00Hz	0.01Hz	1.00Hz	○
F09.10	Zero frequency signal detection value	0.00Hz~upper limit frequency	0.01Hz	0.40Hz	○
F09.11	Zero frequency	0.00Hz~upper limit frequency	0.01Hz	0.10Hz	○

6 Function parameter schedule graph

	backlash				
F09.12	Zero-current detection amplitude	0.0~50.0%	0.1%	0.0%	○
F09.13	Zero-current detection time	0.00~60.00s	0.01s	0.1s	○
F09.14	Over-current detection value	0.0~250.0%	0.1%	160.0%	○
F09.15	Over-current detection time	0.00~60.00s	0.01s	0.00s	○
F09.16	Current 1 arrival detection value	0.0~250.0%	0.1%	100.0%	○
F09.17	Current 1 width	0.0~100.0%	0.1%	0.0%	○
F09.18	Current 2 arriving the detection value	0.0~250.0%	0.1%	100.0%	○
F09.19	Current 2 width	0.0~100.0%	0.1%	0.0%	○
F09.20	Frequency 1 arriving the detection value	0.00Hz~upper limit frequency	0.01Hz	50.00 Hz	○
F09.21	Frequency 1 arriving the detection width	0.00Hz~upper limit frequency	0.01Hz	0.00Hz	○
F09.22	Frequency 2 arriving the detection value	0.00Hz~upper limit frequency	0.01Hz	50.00 Hz	○
F09.23	Frequency 2 arriving the detection width	0.00Hz~upper limit frequency	0.01Hz	0.00Hz	○
F09.24	Positive and negative logic setup of Output terminal	0000~FFFF	1	0000	○
F09.25	Y1 output closed delay time	0.000~50.000s	0.001s	0.000s	○
F09.26	Y1 output disconnected delay time	0.000~50.000s	0.001s	0.000s	○
F09.27	Y2 output closed delay time	0.000~50.000s	0.001s	0.000s	○
F09.28	Y2 output disconnected delay time	0.000~50.000s	0.001s	0.000s	○
F09.29	Reserved				

6 Function parameter schedule graph

~ F09.32					
F09.33	Relay output closed delay time	0.000~50.000s	0.001s	0.000s	○
F09.34	Relay output disconnected delay time	0.000~50.000s	0.001s	0.000s	○
F09.35	Analog output (AO1) selection	0: Output frequency before slip compensation (0.00Hz~upper limit frequency) 1: Output frequency after slip Compensation (0.00Hz~upper limit frequency) 2: Setup frequency (0.00Hz~upper limit frequency) 3: Main setting frequency (0.00Hz~upper limit frequency) 4: Auxiliary setting frequency (0.00Hz~upper limit frequency) 5: Output current 1 (0~2×inverter rated current) 6: Output current 2 (0~3×motor rated current) 7: Output voltage (0~1.2×load motor rated voltage) 8: Busbar voltage (0~1.5×rated busbar voltage) 9: Motor speed (0~3 rated speed) 10: PID provision (0.00~10.00V) 11: PID feedback (0.00~10.00V) 12: AI1 (0.00~10.00V) 13: AI2 (0.00~10.00V or 0~20mA) 14: Communication provision 15: Motor rotor revolving speed (0.00Hz~upper limit frequency) 16: Present setting torque (0~2 times rated torque) 17: Present output torque (0~2 times rated torque) 18: Present torque current (0~2 times motor rated current) 19: Present flux current (0~1 times motor rated flux current) 20~25: Reserved	1	0	○
F09.36	Reserved				

6 Function parameter schedule graph

F09.37	DO function selection (With Y2 reuse)	Same as F09.35	1	0	○
F09.38	Reserved				
F09.39	Analog output (AO1) filter time	0.0~20.0s	0.1s	0.0s	○
F09.40	Analog output (AO1) gain	0.00~2.00	0.01	1.00	○
F09.41	Analog output (AO1) bias	0.0~100.0%	0.1%	0.0%	○
F09.42 ~ F09.44	Reserved				
F09.45	DO filter time	0.0~20.0s	0.1s	0.0s	○
F09.46	DO output gain	0.00~2.00	0.01	1.00	○
F09.47	DO maximum pulse output frequency	0.1~20.0KHz	0.1 KHz	10.0 KHz	○
F09.48	Torque reaches to the detection time	0.02~200.00s	0.01s	1.00s	○
F09.49	Application macro selection	0: General model 1: Compressor application 2: Extruder Application 3: Water pump application 4: Fan application	1	0	×
F09.50 ~ F09.55	Reserved				

F10-Simple PLC/Multi-speed Function Parameter Group

Function Code	Name	Set Range	Min. Unit	Factory Default	Modification
F10.00	Simple PLC operate setting	Units digit: Run mode selection 0: Inaction 1: Stop after single cycle 2: Final value keep after single cycle 3: Continuous cycle Tens digit: Interrupt run restart mode selection 0: Restart from first phase 1: Continuous run from phase frequency at interruption	1	0000	×

6 Function parameter schedule graph

		<p>2: Continuous run from run frequency at interruption Hundreds digit: PLC run time unit 0: Second 1: Minute Thousands digit: Power-down memory selection 0: No memory 1: Phase of reserve power down, frequency power down recording PLC run status: contain power down phase, run frequency, time have run.</p>			
F10.01	Step 1 setting	<p>000H~E22H Units digit: Frequency setup 0: Multi-section frequency i (i=1~15) 1: Frequency determined by complex frequency of main and auxiliary 2: Reserved Tens digit: The selection of running direction for PLC and multi-speed. 0: Forward 1: Reversal 2: Determine by run command Hundreds digit: ACC/DEC time selection 0: ACC/DEC time 1 1: ACC/DEC time 2 2: ACC/DEC time 3 3: ACC/DEC time 4 4: ACC/DEC time 5 5: ACC/DEC time 6 6: ACC/DEC time 7 7: ACC/DEC time 8 8: ACC/DEC time 9 9: ACC/DEC time 10 A: ACC/DEC time 11 B: ACC/DEC time 12 C: ACC/DEC time 13 D: ACC/DEC time 14 E: ACC/DEC time 15</p>	1	020	○

6 Function parameter schedule graph

F10.02	Step 2 setting	000H~E22H	1	020	○
F10.03	Step 3 setting	000H~E22H	1	020	○
F10.04	Step 4 setting	000H~E22H	1	020	○
F10.05	Step 5 setting	000H~E22H	1	020	○
F10.06	Step 6 setting	000H~E22H	1	020	○
F10.07	Step 7 setting	000H~E22H	1	020	○
F10.08	Step 8 setting	000H~E22H	1	020	○
F10.09	Step 9 setting	000H~E22H	1	020	○
F10.10	Step 10 setting	000H~E22H	1	020	○
F10.11	Step 11 setting	000H~E22H	1	020	○
F10.12	Step 12 setting	000H~E22H	1	020	○
F10.13	Step 13 setting	000H~E22H	1	020	○
F10.14	Step 14 setting	000H~E22H	1	020	○
F10.15	Step 15 setting	000H~E22H	1	020	○
F10.16	Step 1 running time	0~6000.0	0.1	10.0	○
F10.17	Step 2 running time	0~6000.0	0.1	10.0	○
F10.18	Step 3 running time	0~6000.0	0.1	10.0	○
F10.19	Step 4 running time	0~6000.0	0.1	10.0	○
F10.20	Step 5 running time	0~6000.0	0.1	10.0	○
F10.21	Step 6 running time	0~6000.0	0.1	10.0	○
F10.22	Step 7 running time	0~6000.0	0.1	10.0	○
F10.23	Step 8 running time	0~6000.0	0.1	10.0	○
F10.24	Step 9 running time	0~6000.0	0.1	10.0	○
F10.25	Step 10 running time	0~6000.0	0.1	10.0	○
F10.26	Step 11 running time	0~6000.0	0.1	10.0	○
F10.27	Step 12 running time	0~6000.0	0.1	10.0	○
F10.28	Step 13 running time	0~6000.0	0.1	10.0	○
F10.29	Step 14 running time	0~6000.0	0.1	10.0	○
F10.30	Step 15 running time	0~6000.0	0.1	10.0	○
F10.31	Multi-frequency 1	0.00Hz~upper limit frequency	0.01Hz	5.00Hz	○
F10.32	Multi-frequency 2	0.00Hz~upper limit frequency	0.01Hz	10.00Hz	○
F10.33	Multi-frequency 3	0.00Hz~upper limit frequency	0.01Hz	20.00Hz	○
F10.34	Multi-frequency 4	0.00Hz~upper limit frequency	0.01Hz	30.00Hz	○
F10.35	Multi-frequency 5	0.00Hz~upper limit frequency	0.01Hz	40.00Hz	○
F10.36	Multi-frequency 6	0.00Hz~upper limit frequency	0.01Hz	45.00Hz	○
F10.37	Multi-frequency 7	0.00Hz~upper limit frequency	0.01Hz	50.00Hz	○
F10.38	Multi-frequency 8	0.00Hz~upper limit frequency	0.01Hz	5.00Hz	○
F10.39	Multi-frequency 9	0.00Hz~upper limit frequency	0.01Hz	10.00Hz	○
F10.40	Multi-frequency 10	0.00Hz~upper limit frequency	0.01Hz	20.00Hz	○
F10.41	Multi-frequency 11	0.00Hz~upper limit frequency	0.01Hz	30.00Hz	○
F10.42	Multi-frequency 12	0.00Hz~upper limit frequency	0.01Hz	40.00Hz	○
F10.43	Multi-frequency 13	0.00Hz~upper limit frequency	0.01Hz	45.00Hz	○
F10.44	Multi-frequency 14	0.00Hz~upper limit frequency	0.01Hz	50.00Hz	○

6 Function parameter schedule graph

Function Code	Name	Set Range	Min. Unit	Factory Default	Modification
F10.45	Multi-frequency 15	0.00Hz~upper limit frequency	0.01Hz	50.00Hz	○
F11-Close loop PID run function parameter group					
F11.00	Closed-loop running control selection	0: PID close loop run control invalid 1: PID close loop run control valid	1	0	×
F11.01	Provision channel selection	0: Digital provision 1: AI1 analog provision 2: AI2 analog provision 3,4: Reserved 5: Pulse provision 6: Communication provision (Communication address: 1D00). 7: Reserved	1	0	○
F11.02	Feedback channel selection	0: AI1 analog input 1: AI2 analog input 2,3: Reserved 4: AI1+AI2 5: AI1-AI2 6: Min { AI1, AI2 } 7: Max { AI1, AI2 } 8: Pulse input 9: Communication feedback (address is 1DOC, 4000 stands for 10.00V)	1	0	○
F11.03	Provision channel filtering time	0.00~50.00s	0.01s	0.00s	×
F11.04	Feedback channel filtering time	0.00~50.00s	0.01s	0.00s	×
F11.05	PID output filtering time	0.00~50.00s	0.01s	0.00s	○
F11.06	Provision digital setting	0.00~10.00V	0.01V	1.00V	○
F11.07	Proportional gain Kp	0.00~100.00	0.01	0.50	○
F11.08	Integral gain Ki	0.01~10.00	0.01	0.25	○
F11.09	Differential gain Kd	0.000~10.00	0.01	0.00	○
F11.10	Sample cycle T	0.01~1.00s	0.01s	0.10s	○
F11.11	Deviation limit	0.0~20.0% correspond to provide value percentage	0.1%	2.0%	○
F11.12	PID differential amplitude limit	0.00~100.00%	0.01%	0.10%	○
F11.13	Closed-loop regulation	0: Action 1: Reaction	1	0	○

6 Function parameter schedule graph

	characteristic				
F11.14	Feedback channel Positive-Negative characteristic	0: Positive characteristic 1: Negative characteristic	1	0	○
F11.15	PID regulation upper limit frequency	0.00Hz~upper limit frequency	0.01Hz	50.00 Hz	○
F11.16	PID regulation lower limit frequency	0.00Hz~upper limit frequency	0.01Hz	0.00Hz	○
F11.17	Integral regulation selection	0: When integral arrival separate PID threshold value, stop integral adjusting 1: When integral arrival separate PID threshold value, continue threshold value adjusting	1	0	○
F11.18	PID threshold of the integral separation	0.0~100.0%	0.1%	100.0 %	○
F11.19	Preset closed-loop frequency	0.00Hz~upper limit frequency	0.01Hz	0.00Hz	○
F11.20	Holding time of preset closed- loop frequency	0.0~6000.0s	0.1s	0.0s	○
F11.21	Closed-loop output reversion selection	0: Close-loop output minus, low limit frequency run. 1: Close-loop output minus, reverse run (Effect by run direction setting) 2: Determined by running demand	1	2	○
F11.22	Closed-loop output Reversion frequency upper limit	0.00Hz~upper limit frequency	0.01Hz	50.00 Hz	○
F11.23	Multiple closed- loop provision 1	0.00~10.00V	0.01V	0.00V	○
F11.24	Multiple closed- loop provision 2	0.00~10.00V	0.01V	0.00V	○
F11.25	Multiple closed- loop provision 3	0.00~10.00V	0.01V	0.00V	○
F11.26	Multiple closed- loop provision 4	0.00~10.00V	0.01V	0.00V	○
F11.27	Multiple closed- loop provision 5	0.00~10.00V	0.01V	0.00V	○
F11.28	Multiple closed- loop provision 6	0.00~10.00V	0.01V	0.00V	○
F11.29	Multiple closed-	0.00~10.00V	0.01V	0.00V	○

6 Function parameter schedule graph

	loop provision 7				
F11.30 ~ F11.36	Reserved				

F12-Constant Pressure Water Supply Function Parameter Group					
Function code	Name	Set range	Min. unit	Factory Default	Modification
F12.00	Constant pressure water supply mode selection	0: No constant pressure water supply 1: Select inverter to achieve one drive two mode 2~4: Reserved 5: Select inverter Y1, Y2 as the double pump timing alternate constant pressure water supply mode	1	0	×
F12.01	Target pressure setting	0.000~long-distance pressure gage range	0.001 Mpa	0.200 Mpa	○
F12.02	Sleep frequency threshold	0.00Hz~upper limit frequency	0.01Hz	30.00 Hz	○
F12.03	Awake pressure threshold	0.000~long-distance pressure gage range	0.001 Mpa	0.150 Mpa	○
F12.04	Sleep delay time	0.0~6000.0s	0.1s	0.0s	○
F12.05	Revival delay time	0.0~6000.0s	0.1s	0.0s	○
F12.06	The range of long-distance manometer	0.001~9.999Mpa	0.001 Mpa	1.000 Mpa	○
F12.07 ~ F12.09	Reserved				
F12.10	Automatic switching time interval	0000~65535 minute	1	0	×
F12.11	Revival mode selection	0: Awake by the value of F12.03 1: Awake by the value of F12.12*F12.01	1	0	○
F12.12	Revival pressure coefficient	0.01~0.99	0.01	0.75	○
F12.13	Reserved				
F12.14	Water shortage protection mode	0: Water shortage protection is invalid 1: Water shortage protection through the defined water shortage input X terminal 2: Water shortage protection through output current and frequency	1	0	○

6 Function parameter schedule graph

F12.15	Water shortage protection current	10%~150%	1%	80%	○
F12.16	Wake up time again after water shortage protection	0~3000min	1min	60min	○
F12.17	Water shortage protection judgment time	1.0~100.0s	0.1s	5.0s	○
F12.18	Reserved				

F13- Traverse/ Fixed Length Control Function Parameter Group

Function Code	Name	Set Range	Min. Unit	Factory Default	Modification
F13.00	Traverse function selection	0: Traverse invalid 1: Traverse valid	1	0	×
F13.01	Traverse operating mode	Units digit: Enter mode 0: Automatically enter 1: Terminal enter manually Tens digit: Swing frequency amplitude input method selection 0: Variable swing 1: Fixed swing Hundreds digit: Traverse halt start mode selection 0: Restart 1: Start as previous halt record Thousands digit: Traverse status reserve selection 0: No reserve 1: Reserve	1	0000	×
F13.02	Traverse frequency swing value	0.0~50.0%	0.1%	10.0%	○
F13.03	Sudden-Jump frequency	0.0~50.0%	0.1%	2.0%	○
F13.04	Traverse cycle	0.1~999.9s	0.1s	10.0s	○
F13.05	Triangular wave rising time	0.0~98.0% (Traverse cycle)	0.1%	50.0%	○
F13.06	Preset frequency of Traverse	0.00~400.00Hz	0.01Hz	0.00Hz	○
F13.07	Traverse preset frequency waiting time	0.0~6000.0s	0.1s	0.0s	○
F13.08	Setting length	0~65535 (m/cm/mm)	1	0	○

6 Function parameter schedule graph

F13.09	Number of pulses for axis per circle	1~10000	1	1	○
F13.10	Axis perimeter	0.01~655.35cm	0.01cm	10.00cm	○
F13.11	Percentage of remaining length	0.00%~100.00%	0.01%	0.00%	○
F13.12	Length correction coefficient	0.001~10.000	0.001	1.000	○
F13.13	After length arrival: record length manage	Units digit: Reserved Tens digit: Sets the unit of length 0: Meter (m) 1: Centimeter (cm) 2: Millimeter (mm) Hundreds digit: Actions when the length is reached 0: Continue running 1: Shut down according to stopping mode 2: Loop length control Thousands digit: Software reset length (Could be cleared by communication) 0: No operation 1: The current length is cleared 2: The current length and total length both cleared	1	0000	○
F13.14	Record length manage	Units digit: Stops the current length 0: Automatically cleared 1: Length is maintained Tens digit: Power-down length memory setting 0: Not stored 1: Stored Hundreds digit: length calculation at shutdown 0: The length is not calculated 1: Calculate the length	0	011	○

F14-Vector Control Parameter Group

Function code	Name	Set Range	Min. Unit	Factory Default	Modification
F14.00	Speed/torque control selection	0: Speed control 1: Torque control	1	0	○
F14.01	Speed loop high speed proportional of	0.1~40.0	0.1	20.0	○

6 Function parameter schedule graph

	Asynchronous machine				
F14.02	Speed loop high speed integral time of Asynchronous machine	0.001~10.000s	0.001s	0.040s	○
F14.03	Speed loop low speed proportional of Asynchronous machine	0.1~80.0	0.1	20.0	○
F14.04	Speed loop low speed integral of Asynchronous machine	0.001~10.000s	0.001s	0.020s	○
F14.05	Speed loop parameter of Asynchronous machine	0.00Hz~20.00Hz	0.01Hz	5.00Hz	○
F14.06	Low frequency power generation stability of Asynchronous machine	0~50	1	25	○
F14.07	Current loop proportional of Asynchronous machine	1~500	1	150	○
F14.08	Current loop integral time of Asynchronous machine	0.1~100.0ms	0.1ms	4.0ms	○
F14.09	Motor-driven torque current of Asynchronous machine	50%~200%	1%	100%	○
F14.10	Braking torque current limit of Asynchronous machine	30%~300%	1%	100%	○
F14.11	Asynchronous motor flux-weakening control	20.0~100.0%	0.1%	80.0%	○
F14.12	Asynchronous motor over modulation coefficient	95%~115%	1%	100%	○
F14.13	Asynchronous motor flux braking coefficient	0.0~300.0%	0.1%	0.0%	○
F14.14	Asynchronous motor pre-excitation start time constant	0.1~3.0	0.1	0.5	×
F14.15 ~ F14.18	Reserved				
F14.19	Electric torque current limit value	0.0~250.0%	0.1%	160.0%	○
F14.20	Brake torque current limit value	0.0~250.0%	0.1%	160.0%	○
F14.21	Torque setting and limited channel selection	Units digit: Torque provision channel selection 0: Digital setting (Determined	1	000	○

6 Function parameter schedule graph

		<p>by F14.23)</p> <p>1: AI1 Analog setting 2: AI2 Analog setting 3: Terminal UP/DOWN adjustment setting 4: Communication provision (Communication address: 1E01) 5,6: Reserved 7: Rapid pulse setting (X5 terminal needs to choose the corresponding function) 8: Terminal pulse width setting (X5 terminal needs to choose the corresponding function) Tens digit: Electric torque limit channel selection 0: Digital setting (determined by F14.19) 1: AI1 analog setting 2: AI2 analog setting 3: Terminal UP / DOWN adjustment setting 4,5,6: Reserved 7: High-speed pulse setting (X5 terminals need to select the appropriate function) 8: Terminal pulse width setting (X5 terminals need to select the appropriate function) Note: The maximum value of 1 ~ 8 channels corresponds to F14.19 Hundreds digit: Braking torque limit channel selection 0: Digital setting (Determined by F14.20) 1: AI1 analog setting 2: AI2 analog setting 3: Terminal UP / DOWN adjustment setting 4,5,6: Reserved 7: High-speed pulse setting (X5 terminals need to select the appropriate function) 8: Terminal pulse width setting</p>			
--	--	--	--	--	--

		(X5 terminals need to select the appropriate function) Note: The maximum value of 1 ~ 8 channels corresponds to F14.20			
F14.22	Torque polarity setting	0000~2112 Units digit: Torque setting polarity 0: Positive 1: Negative 2: defined by running command Tens digit: Torque compensation polarity 0: The same as setting direction of torque 1: opposite the setting direction of torque Hundreds digit: F14.29 compensation weakened when the motor locked rotor 0: Invalid 1: Enable. Thousands digit: Torque control anti-reverse function 0: Invalid 1: Anti-reverse function is active continuously 2: Anti-reversal function enabled at startup.	1	2000	○
F14.23	Torque digital setting value	0.0~200.0%	0.1%	0.0%	○
F14.24	Forward speed limit channel selection in Torque control mode	0: Digital setting 1: AI1 Analog setting 2: AI2 Analog setting 3: Terminal UP/DOWN adjustment setting 4: Communication provision (Communication address: 1D0A). 5,6: Reserved 7: Rapid pulse setting (X5 terminal needs to choose the corresponding function) 8: Terminal pulse width setting (X5 terminal needs to choose	1	0	×

6 Function parameter schedule graph

		the corresponding function)			
F14.25	Reverse speed limit channel selection in Torque control mode	0: Digital setting 1: AI1 Analog setting 2: AI2 Analog setting 3: Terminal UP/DOWN adjustment setting 4: Communication provision (Communication address: 1D0B). 5,6: Reserved 7:Rapid pulse setting (X5 terminal needs to choose the corresponding function) 8: Terminal pulse width setting (X5 terminal needs to choose the corresponding function)	1	0	×
F14.26	Forward speed limit value in Torque control mode	0.00Hz~upper limit frequency	0.01Hz	50.00 Hz	○
F14.27	Reverse speed limit value in Torque control mode	0.00Hz~upper limit frequency	0.01Hz	50.00 Hz	○
F14.28	Torque Accelerate/Decelerate time setting	0.000~60.000s	0.001s	0.100s	○
F14.29	Torque compensation	0.0~100.0%	0.1%	0.0%	○
F14.30	Torque compensation cut-off frequency	0.00Hz~upper limit frequency	0.01Hz	20.00 Hz	○
F14.31	Positive torque gain regulation	50.0~150.0%	0.1%	100.0 %	○
F14.32	Negative torque gain regulation	50.0~150.0%	0.1%	100.0 %	○
F14.33	Reserved				
F14.34	Reserved				
F14.35	Synchronous machine field weakening control method	0: Direct calculation 1: Automatic adjustment 2: Not weakening	1	1	×
F14.36	Synchronous machine field weakening current coefficient	0~120%	1%	80%	○
F14.37	Synchronous machine weakening adjustment coefficient	1~10	1	4	○
F14.38	Synchronous machine field weakening output voltage adjustment coefficient	0~100	1	40	○

6 Function parameter schedule graph

F14.39	Synchronous machine high-speed PI adjustment integral coefficient	0~6000	1	150	○
F14.40	Synchronous machine high-speed PI adjustment proportional coefficient	0~6000	1	60	○
F14.41	Synchronous machine low-speed PI adjustment integral coefficient	0~6000	1	150	○
F14.42	Synchronous machine low-speed PI adjustment proportional coefficient	0~6000	1	60	○
F14.43	Synchronous machine speed PI switching frequency point 1	0.00~F14.44	0.01Hz	1.00Hz	○
F14.44	Synchronous machine speed PI switching frequency point 2	0.00~upper limit frequency	0.01Hz	2.00Hz	○
F14.45	Synchronous machine Rotating speed filter coefficient	4~512	1	56	○
F14.46	Synchronous machine low speed filter coefficient	4~512	1	16	○
F14.47	Synchronous machine low-speed carrier frequency	2.0~10.0K	0.1K	2.0K	○
F14.48	Synchronous machine recognizes back-EMF current/low-speed minimum current	0~100%	1%	30%	×
F14.49	Reserved				
F14.50	Synchronous machine speed estimation parameter 1	1~1000	1	20	○
F14.51	Synchronous machine speed estimation parameter 2	1~1000	1	30	○
F14.52	Synchronous machine start preset current	0~200	1%	0	○
F14.53	Synchronous machine start initial position detection method	0: Do not detect the initial position 1: Method of detecting initial position	1	0	○

6 Function parameter schedule graph

F14.54	Synchronous machine starts initial position detection pulse current	0~200%	1%	120%	○
F14.55	Synchronous machine D axis current PI adjustment integral coefficient	0~6000	1	200	○
F14.56	Synchronous machine D axis current PI adjustment proportional coefficient	0~6000	1	300	○
F14.57	Synchronous machine Q axis current PI adjustment integral coefficient	0~6000	1	200	○
F14.58	Synchronous machine Q axis current PI adjustment proportional coefficient	0~6000	1	300	○
F14.59	Synchronous machine initial position detection time	0~60000	1	0	×
F14.60 ~ F14.69	Reserved				

F15-Asynchronous Motor Parameter Group

Function code	Name	Set Range	Min. Unit	Factory Default	Modification
F15.00	Motor type	0: Asynchronous motor 1: Synchronous motor	1	0	×
F15.01	Asynchronous motor rated power	0.1~6553.5KW	0.1KW	Base on motor type	×
F15.02	Asynchronous motor rated voltage	1~690V	1V	Base on motor type	×
F15.03	Asynchronous motor rated current	0.1~6553.5A	0.1A	Base on motor type	×
F15.04	Asynchronous motor rated frequency	0.00~600.00Hz	0.01Hz	Base on motor type	×
F15.05	Asynchronous motor rated rotational speed	0~60000r/min	1r/min	Base on motor type	×
F15.06	Number of motor pole pairs	1~100	1	2	×
F15.07	Asynchronous motor stator resistance	0.001~65.535Ω (Inverter power < 7.5KW)	0.001Ω	Base on motor type	×
		0.0001~6.5535Ω	0.0001		

6 Function parameter schedule graph

		(Inverter power \geq 7.5KW)	Ω		
F15.08	Asynchronous motor rotor resistance	0.001~65.535 Ω (Inverter power $<$ 7.5KW)	0.001 Ω	Base on motor type	×
		0.0001~6.5535 Ω (Inverter power \geq 7.5KW)	0.0001 Ω		
F15.09	Asynchronous motor leakage inductance	0.01~655.35mH (Inverter power $<$ 7.5KW)	0.01mH	Base on motor type	×
		0.001~65.535mH (Inverter power \geq 7.5KW)	0.001mH		
F15.10	Asynchronous motor mutual inductance	0.1~655.35mH (Inverter power $<$ 7.5KW)	0.1mH	Base on motor type	×
		0.01~655.35mH (Inverter power \geq 7.5KW)	0.01mH		
F15.11	Asynchronous motor no load current	0.01~655.35A	0.01A	Base on motor type	×
F15.12	Synchronous motor stator resistance	0.001~65.535 Ω (Inverter power $<$ 7.5KW)	0.001 Ω	Based on motor type	×
		0.0001~6.5535 Ω (Inverter power \geq 7.5KW)	0.0001 Ω		
F15.13	Synchronous machine D axis inductance	0.01~655.35mH (Inverter power $<$ 7.5KW)	0.01mH	Based on motor type	×
		0.001~65.535mH (Inverter power \geq 7.5KW)	0.001mH		
F15.14	Synchronous machine Q axis inductance	0.01~655.35mH (Inverter power $<$ 7.5KW)	0.01mH	Based on motor type	×
		0.001~65.535mH (Inverter power \geq 7.5KW)	0.001mH		
F15.15	Synchronous machine back EMF coefficient	0~60000	1	Based on motor type	×
F15.16 ~ F15.18	Reserved				
F15.19	Motor parameter self-tuning selection	0: Inaction 1: Asynchronous motor stop to self-adjusting 2: Asynchronous motor rotate no-load to self-adjusting 3: Reserved Note: ① Before adjustment, The nameplate data and F15.00 should be set correctly	1	00	×

6 Function parameter schedule graph

		<p>② Motor parameter group can have special default values, or can be modified by users, or can be self-adjusted.</p> <p>③ When parameter F15.01 is modified, the other parameters of the motor will turn into default values automatically.</p>			
F15.20	Synchronous motor inductance identification coefficient	0~2	1	0	×
F15.21	Reserved				
F15.22	Reserved				

F16- Monitoring parameter group

Function code	Name	Set Range	Min. Unit	Factory Default	Modification
F16.00 ~ F16.79	Reserved				

F17-Reserved parameter group 1

Function code	Name	Set Range	Min. Unit	Factory Default	Modification
F17.00	Main set frequency	-	0.01Hz	-	*
F17.01	Auxiliary setting frequency	-	0.01Hz	-	*
F17.02	Set frequency	-	0.01Hz	-	*
F17.03	Output synchronization frequency	-	0.01Hz	-	*
F17.04	Output current	-	0.1A	-	*
F17.05	The output voltage	-	1V	-	*
F17.06	DC bus voltage	-	0.1V	-	*
F17.07	Load motor rotating speed	-	1 Rev/Min	-	*
F17.08	Load motor linear speed	-	1 Rev/Min	-	*
F17.09	Inverter temperature	-	1°C	-	*
F17.10	This running time	-	0.1 Min	-	*
F17.11	Current cumulative running time	-	1Hour	-	*
F17.12	Current cumulative power-on time	-	1 Hour	-	*
F17.13	Inverter status	-	-	-	*

6 Function parameter schedule graph

F17.14	Input terminal status	-	-	-	*
F17.15	Output terminal status	-	-	-	*
F17.16	Reserved	-	-	-	*
F17.17	Reserved	-	-	-	*
F17.18	Communication virtual input terminal status	-	-	-	*
F17.19	Internal virtual input node status	-	-	-	*
F17.20	Analog input AI1 (After calibration)	-	0.01V	-	*
F17.21	Analog input AI2 (After calibration)	-	0.01V or 0.01mA	-	*
F17.22	Reserved	-	-	-	*
F17.23	Reserved	-	-	-	*
F17.24	Analog output AO1 (After calibration)	-	0.01V or 0.01mA	-	*
F17.25	Reserved	-	-	-	*
F17.26	Reserved	-	-	-	*
F17.27	Reserved	-	-	-	*
F17.28	External pulse input frequency (before calibration)	-	1Hz	-	*
F17.29	Reserved	-	-	-	*
F17.30	Process PID given	-	0.01V	-	*
F17.31	Process PID feedback	-	0.01V	-	*
F17.32	Process PID error	-	0.01V	-	*
F17.33	Process PID output	-	0.01Hz	-	*
F17.34	Simple PLC current state number	-	-	-	*
F17.35	Current stage number of external multi-stage speed	-	-	-	*
F17.36	Constant pressure water supply given pressure	-	0.001Mpa	-	*
F17.37	Constant pressure water supply feedback pressure	-	0.001Mpa	-	*
F17.38	Constant pressure water supply relay status	-	-	-	*
F17.39	Current length	-	m/cm/mm	-	*
F17.40	Cumulative length	-	m/cm/mm	-	*
F17.41	Current internal count value	-	-	-	*
F17.42	Current internal timing value	-	0.1s	-	*
F17.43	Run command to set channel	0: Keyboard 1: Terminal 2: Communication	-	-	*
F17.44	Main frequency given channel	-	-	-	*
F17.45	Auxiliary frequency given channel	-	-	-	*

6 Function parameter schedule graph

F17.46	Inverter rated current	-	0.1A	-	*
F17.47	Inverter rated voltage	-	1V	-	*
F17.48	Inverter rated power	-	0.1KW	-	*
F17.49	Electric torque limit value	-	0.1% motor rated torque	-	*
F17.50	Brake torque limit value	-	0.1% motor rated torque	-	*
F17.51	Frequency after acceleration or deceleration	-	0.01Hz	-	*
F17.52	Motor rotor frequency	-	0.01Hz	-	*
F17.53	Current given torque	-	0.1% motor rated torque, with direction	-	*
F17.54	Current output torque	-	0.1% motor rated torque, with direction	-	*
F17.55	Current torque current	-	0.1A	-	*
F17.56	Current flux current	-	0.1A	-	*
F17.57	Set motor rotating speed	-	r/min	-	*
F17.58	Output Power	-	0.1KW	-	*
F17.59	Low order total power consumption	-	1 degree	-	*
F17.60	High order total power consumption	-	1 mean 10000 degrees	-	*
F17.61 ~ F17.75	Reserved	-		-	*

F18-Enhance Control Parameter Group

Function code	Name	Set Range	Min. Unit	Factory Default	Modification
F18.00	Operation panel control frequency binding	0: No binding 1: Operation keyboard digital setup 2: AI1 analog setup 3: AI2 analog setup 4: Terminal UP/DOWN adjusting setup 5: Communication provide (Modbus and external bus use the same main frequency storage) 6,7: Reserved 8: High speed pulse setup(X5 terminal need choose the relative function) 9: Terminal pulse width setup(X5 terminal need choose the relative function)	1	0	○

6 Function parameter schedule graph

		10: Terminal encoder provide(Decide by X1, X2) 11~15: Reserved			
F18.01	Terminal control frequency binding	Same as above	1	0	○
F18.02	Communication control frequency binding	Same as above	1	0	○
F18.03	Digital frequency integral function selection	Units digit: Keyboard UP/DW integral control 0: Integral function 1: No integral function Tens digit: terminal UP/DW integral control 0: Integral function 1: No integral function Hundreds digit: Keyboard shuttle knob enable (Shuttle keyboard effective) 0: The shuttle knob is valid in the monitoring interface 1: The shuttle knob is invalid in the monitoring interface 2: In the monitoring interface, the UP DW and jog dial adjustments are invalid. Thousands digit: Keypad adjustment of frequency classic mode selection 0: Invalid 1: Valid, adjustment range decided by F18.05	1	0000	○
F18.04	Keyboard UP/DOWN integral rate	0.01~50.00Hz	0.01Hz	0.10Hz	○
F18.05	Keyboard no integral single step's size setup	0.01~10.00Hz	0.01Hz	0.01Hz	○
F18.06	Terminal UP/DOWN integral rate	0.01~50.00Hz	0.01Hz	0.20Hz	○
F18.07	Terminal no integral single step's size setup	0.01~10.00Hz	0.01Hz	0.10Hz	○
F18.08	Droop control decline frequency	0.00~10.00Hz	0.01Hz	0.00Hz	○

6 Function parameter schedule graph

F18.09	Setup accumulate power on time	0~65535 hours	1	0	○
F18.10	Setup accumulate run time	0~65535 hours	1	0	○
F18.11	Timing run function enable	0: Invalid 1: Valid	1	0	○
F18.12	Timing run stop time	0.1~6500.0Min	0.1Min	2.0Min	○
F18.13	Currently run arrival time	0.0~6500.0Min	0.1Min	1.0Min	○
F18.14	Keyboard UP/DOWN selection under monitor mode	0: Keyboard frequency provide value adjusting 1: PID digital provide value adjusting 2~6: Reserved	1	0	○
F18.15	V/F vibration restrain end frequency	0.00Hz~upper limit frequency	0.01Hz	50.00Hz	○
F18.16	Advanced control functions	Units digit : Reserved Tens digit: Torque limit mode (valid for asynchronous motor) 0: Torque limit according to rated current of frequency converter 1: Torque limit according to rated torque current Hundreds digit: Fast through function when less than the lower limit frequency 0: Invalid 1: Valid Thousands digit: In torque control mode, Low torque given PWM blocking function (Thousands digit is valid when F00.24=1) 0: Invalid 1: Valid	1	0000	○
F18.17	Cooling fan control selection	Units digit: Fan control mode 0: Smart fan 1: Inverter is running all the time after power on 2: No running for fan, but it starts automatically when the temperature is higher than 75 degree. Tens digit: Speed regulation fan control mode. 0: Smart PWM Speed regulation 1: Running at highest speed.	1	10	○

6 Function parameter schedule graph

F18.18	Current detection delay compensation	0~500	1	5	○
F18.19	Low-order of total power consumption	0~9999	1Kwh	0	○
F18.20	High-order of total power consumption	0~65535 (1represent 10000kwh)	10000 kwh	0	○
F18.21	Correction factor of power consumption calculation	50.0%~200.0%	0.1%	100.0 %	○
F18.22	V/F separate control voltage reference channel	0: Digital setting (Determined by 18.23) 1: AI1 analog setting 2: AI2 analog setting 3: Terminal UP/DOWN adjustment setting 4~6: Reserved 7: High-speed pulse setting (X5 terminals need to select the appropriate function) 8: Terminal pulse width setting (X5 terminals need to select the appropriate function) Note: The maximum value of 0 ~ 8 channels correspond to the motor rated voltage	1	1	○
F18.23	V/F separate control voltage digital reference	0.0%~100.0%	0.1%	0.0%	○
F18.24 ~ F18.29	Reserved				

F19-Protective Relevant Function Parameter Group

Function code	Name	Set Range	Min. Unit	Factory Default	Modification
F19.00	Power off restart waiting time	0.0~20.0s (0 means no start function)	0.1s	0.0s	×
F19.01	Fault self-recovery times	0~10 (0 means no automatic reset function)	1	0	×
F19.02	Fault self-recovery interval time	0.5~20.0s	0.1s	5.0s	×
F19.03	Motor overload	0: Alarm, Continuous run	1	2	○

6 Function parameter schedule graph

	protection action selection	1: Alarm, Stop run as halt mode 2: Fault, free halt			
F19.04	Motor overload protection coefficient	10.0~2000.0% (Motor rated current)	0.1%	100.0%	○
F19.05	Inverter overload pre-alarm detection selection	0: Detection all the time 1: Detection as constant velocity	1	0	○
F19.06	Inverter overload pre-alarm detection level	20~180% (Inverter rated current)	1%	130%	○
F19.07	Inverter overload pre-alarm delay time	0.0~20.0s	0.1s	5.0s	○
F19.08	Motor under load alarm detection level	0.0~120.0% (Motor rated current)	0.1%	50.0%	○
F19.09	Motor under load alarm detection time	0.1~60.0s	0.1s	2.0s	○
F19.10	Motor under load alarm detection action	Units digit: detection selection 0: No detection 1: Detection all the time when run 2: Detection only when constant velocity Tens digit: Action selection 0: Alarm, continuous run 1: Alarm, stop run as halt mode 2: Fault, free halt	1	00	○
F19.11	Input& output phase loss, short circuit detection action	Units digit: Input phase loss 0: No detection 1: Fault, free halt Tens digit: Output phase loss 0: No detection 1: Fault, free halt Hundreds digit: Power-on on earth short circuit protect detection enable 0: No detection 1: Fault, free halt Thousands digit: Reserved	1	0111	○
F19.12	Over voltage stall selection	0: Forbid 1: Allowed	1	1	×
F19.13	Over voltage stall protection voltage	100~150% (Rated busbar voltage)	1%	125%	×
F19.14	Automatic current limit level	50~230% (G type rated current)	1%	170%	×

6 Function parameter schedule graph

F19.15	Frequency decline rate of automatic current limit	0.00~99.99Hz/s	0.01 Hz/s	10.00 Hz/s	×
F19.16	Automatic current limit action selection	0: Constant velocity invalid 1: Constant velocity valid	1	0	×
F19.17	Rapid current-limiting coefficient	150%~250% (G type rated current)	1%	230%	×
F19.18	Motor run section selection when instant power off	0: Forbid 1: Allowed	1	0	×
F19.19	Frequency droop rate when instant power off	0.00~99.99Hz/s	0.01 Hz/s	10.00 Hz/s	×
F19.20	Voltage rebound estimate time when instant power off	0.00~10.00s	0.01s	0.10s	×
F19.21	Action estimate voltage when instant power off	60~100% (Rated busbar voltage)	1%	80%	×
F19.22	Allowed the longest off time when instant power off	0.30~5.00s	0.01s	2.00s	×
F19.23	Terminal external device fault action selection	0: Alarm, Continuous run 1: Alarm, Stop run as halt mode 2: Fault, Free halt	1	2	×
F19.24	Power on terminal protection selection	0:Invalid 1:Valid	1	0	×
F19.25	Provide lost detection value	0~100%	1%	0%	○
F19.26	Provide lost detection time	0.0~500.0s	0.1s	0.5s	○
F19.27	Feedback lost detection value	0~100%	1%	12%	○
F19.28	Feedback lost detection time	0.0~500.0s	0.1s	0.5s	○
F19.29	Deviation magnitude abnormal detection value	0~100%	1%	50%	○
F19.30	Deviation magnitude abnormal detection time	0.0~500.0s	0.1s	0.5s	○
F19.31	Protection action selection 1	Units digit: PID provide loss detection act	1	000	○

6 Function parameter schedule graph

		<p>0: No detection 1: Alarm, continue run 2: Alarm, stop run as halt mode 3: Fault, free halt</p> <p>Tens digit: PID feedback loss detection act 0: No detection 1: Alarm, continue run 2: Alarm, stop run as halt mode 3: Fault, free halt</p> <p>Hundreds digit: PID error value abnormal detect action 0: No detection 1: Alarm, continue run 2: Alarm, stop run as halt mode 3: Fault, free halt</p>			
F19.32	Protection action selection 2	<p>Units digit: Communication abnormal action: include communication time out and error 0: Alarm, continue run 1: Alarm, stop run as halt mode 2: Fault, free halt</p> <p>Tens digit: E²PROM abnormal action selection 0: Alarm, continue run 1: Alarm, stop run as halt mode 2: Fault, free halt</p> <p>Hundreds digit: Reserved Thousands digit: Running lack-Voltage fault display action selection. 0: No detection 1: Fault, free halt</p>	1	1200	×
F19.33	Reserved				
F19.34	Reserved				
F19.35	Fault indication and clock during the period of recovery	<p>Units digit: Fault indication selection during the period of fault reset automatically 0: Action 1: No action</p> <p>Tens digit: Fault clock function selection, to achieve fault display before power down, etc. 0: Forbid 1: Open</p>	1	00	×

6 Function parameter schedule graph

F19.36	Continuous run frequency selection when alarm	Match up with protect action 0: Run at the frequency setup by now 1: Run at the frequency of upper limit 2: Run at the frequency of low limit 3: Run at the frequency of abnormal for standby	1	0	×
F19.37	Abnormal standby frequency	0.00Hz~upper limit frequency	0.01Hz	10.00 Hz	×
F19.38	Reserved				
F19.39	Over speed (OS) detection time	0.0~120.0% (Equals upper limit frequency)	0.1%	120.0 %	○
F19.40	Over speed (OS) detection time	0.00~20.00s (No detection when value is 0)	0.01s	0.00s	○
F19.41	Detection value when speed deviation is too large	0.0~50.0% (Equals upper limit frequency)	0.1%	10.0%	○
F19.42	Detection time when speed deviation is too large	0.00~20.00s (No detection when value is 0)	0.01s	0.00s	○
F19.43	Overvoltage suppression coefficient	0.0~100.0% (SVC control of asynchronous machine is valid)	0.1%	0.0%	○
F19.44	Fans start temperature	0~100°C	1	75°C	○
F19.45 ~ F19.50	Reserved				

F20-Internal Virtual Input Output Node Parameter Group

Function code	Name	Set Range	Min. Unit	Factory Default	Modification
F20.00	Virtual input VDI1 function selection	0~90	1	0	○
F20.01	Virtual input VDI2 function selection	0~90	1	0	○
F20.02	Virtual input VDI3 function selection	0~90	1	0	○
F20.03	Virtual input VDI4 function selection	0~90	1	0	○
F20.04	Virtual input VDI5 function selection	0~90	1	0	○

6 Function parameter schedule graph

F20.05	Virtual output VDO1 function selection	0~60	1	0	○
F20.06	Virtual output VDO2 function selection	0~60	1	0	○
F20.07	Virtual output VDO3 function selection	0~60	1	0	○
F20.08	Virtual output VDO4 function selection	0~60	1	0	○
F20.09	Virtual output VDO5 function selection	0~60	1	0	○
F20.10	Virtual output VDO1 open delay time	0.00~600.00s	0.01s	0.00s	○
F20.11	Virtual output VDO2 open delay time	0.00~600.00s	0.01s	0.00s	○
F20.12	Virtual output VDO3 open delay time	0.00~600.00s	0.01s	0.00s	○
F20.13	Virtual output VDO4 open delay time	0.00~600.00s	0.01s	0.00s	○
F20.14	Virtual output VDO4 open delay time	0.00~600.00s	0.01s	0.00s	○
F20.15	Virtual output VDO1 close delay time	0.00~600.00s	0.01s	0.00s	○
F20.16	Virtual output VDO2 close delay time	0.00~600.00s	0.01s	0.00s	○
F20.17	Virtual output VDO3 close delay time	0.00~600.00s	0.01s	0.00s	○
F20.18	Virtual output VDO4 close delay time	0.00~600.00s	0.01s	0.00s	○
F20.19	Virtual output VDO5 close delay time	0.00~600.00s	0.01s	0.00s	○
F20.20	Virtual input VDI enable control	00~FF	1	00	○
F20.21	Virtual input VDI status digital setup	00~FF	1	00	○
F20.22	Virtual Input/ Output connection	00~FF Bit0:VDI1 and VDO1 connection 0:Positive logic 1:Negative logic Bit1:VDI2 and VDO2 connection 0:Positive logic 1:Negative logic Bit2:VDI3 and VDO3 connection 0:Positive logic 1:Negative logic	1	00	○

6 Function parameter schedule graph

		Bit3:VDI4 and VDO4 connection 0:Positive logic 1:Negative logic Bit4:VDI5 and VDO5 connection 0:Positive logic 1:Negative logic			
--	--	--	--	--	--

F21-Reserved parameter Group

Function code	Name	Set Range	Min. Unit	Factory Default	Modification
F21.00 ~ F21.12	Reserved				

F22- Reserved parameter Group

Function code	Name	Set Range	Min. Unit	Factory Default	Modification
F22.00 ~ F22.35	Reserved				

F23- Reserved parameter Group

Function code	Name	Set Range	Min. Unit	Factory Default	Modification
F23.00 ~ F23.18	Reserved				

F24-Lift special parameter group

Function code	Name	Set Range	Min. Unit	Factory Default	Modification
F24.00	Rising brake release frequency	0.0~10.00Hz	0.01Hz	0.00Hz	×
F24.01	Delay of rising brake release frequency	0.01~10.00s	0.01s	0.40s	×
F24.02	Rising brake release current value (Percentage of motor rated current)	0~200.0%	0.1%	50.0%	×
F24.03	Rising brake release time	0~10.00s	0.01s	0.20s	×
F24.04	Falling brake release	0.60~10.00Hz	0.01Hz	1.00Hz	×

6 Function parameter schedule graph

	frequency				
F24.05	Delay of falling brake release frequency	0.01~10.00s	0.1s	1.00s	×
F24.06	Falling brake release current value	0~200.0%	0.1%	20.0%	×
F24.07	Falling brake release action time	0~10.00s	0.1s	0.4s	×
F24.08	Rising stop brake frequency	0.60~10.00Hz	0.01Hz	1.00Hz	×
F24.09	Rising stop brake delay	0~10.00s	0.01s	0.40s	×
F24.10	Rising stop brake action time	0~10.00s	0.01s	0.10s	×
F24.11	Falling stop brake frequency	0.60~10.00Hz	0.01Hz	1.00Hz	×
F24.12	Falling stop brake delay	0~10.00s	0.1s	0.50s	×
F24.13	Falling stop brake action	0~10.00s	0.1s	0.50s	×

F25-User Definition Display Parameter Group

Function code	Name	Set Range	Min. Unit	Factory Default	Modification
F25.00	User Function Code 1	F00.00~F25.xx	0.01	25.00	○
F25.01	User Function Code 2	F00.00~F25.xx	0.01	25.00	○
F25.02	User Function Code 3	F00.00~F25.xx	0.01	25.00	○
F25.03	User Function Code 4	F00.00~F25.xx	0.01	25.00	○
F25.04	User Function Code 5	F00.00~F25.xx	0.01	25.00	○
F25.05	User Function Code 6	F00.00~F25.xx	0.01	25.00	○
F25.06	User Function Code 7	F00.00~F25.xx	0.01	25.00	○
F25.07	User Function Code 8	F00.00~F25.xx	0.01	25.00	○
F25.08	User Function Code 9	F00.00~F25.xx	0.01	25.00	○
F25.09	User Function Code 10	F00.00~F25.xx	0.01	25.00	○
F25.10	User Function Code 11	F00.00~F25.xx	0.01	25.00	○
F25.11	User Function Code 12	F00.00~F25.xx	0.01	25.00	○
F25.12	User Function Code 13	F00.00~F25.xx	0.01	25.00	○
F25.13	User Function Code 14	F00.00~F25.xx	0.01	25.00	○
F25.14	User Function Code 15	F00.00~F25.xx	0.01	25.00	○
F25.15	User Function Code 16	F00.00~F25.xx	0.01	25.00	○
F25.16	User Function Code 17	F00.00~F25.xx	0.01	25.00	○
F25.17	User Function Code 18	F00.00~F25.xx	0.01	25.00	○
F25.18	User Function Code 19	F00.00~F25.xx	0.01	25.00	○
F25.19	User Function Code 20	F00.00~F25.xx	0.01	25.00	○
F25.20	User Function Code 21	F00.00~F25.xx	0.01	25.00	○

6 Function parameter schedule graph

F25.21	User Function Code 22	F00.00~F25.xx	0.01	25.00	○
F25.22	User Function Code 23	F00.00~F25.xx	0.01	25.00	○
F25.23	User Function Code 24	F00.00~F25.xx	0.01	25.00	○
F25.24	User Function Code 25	F00.00~F25.xx	0.01	25.00	○
F25.25	User Function Code 26	F00.00~F25.xx	0.01	25.00	○
F25.26	User Function Code 27	F00.00~F25.xx	0.01	25.00	○
F25.27	User Function Code 28	F00.00~F25.xx	0.01	25.00	○
F25.28	User Function Code 29	F00.00~F25.xx	0.01	25.00	○
F25.29	User Function Code 30	F00.00~F25.xx	0.01	25.00	○

F26-Fault Record Function Parameter Group

Function Code	Name	Set Range	Min. Unit	Factory Default	Modification
F26.00	The last fault record	0:No fault 1:Overcurrent at acceleration 2:Overcurrent at deceleration 3:Overcurrent at constant speed 4:Overvoltage at acceleration 5:Overvoltage at deceleration 6:Overvoltage at constant speed 7:Overvoltage at motor halt 8:Undervoltage at run 9:Drive overload protection 10:Motor overload protection 11:Motor under load protection 12:Input phase loss 13:Output phase loss 14:Inverter module protection 15:Reserved 16:Short circuit to earth when power on 17:Drive overheat 18:External device fault 19:Current detect circuit fault 20:External interference fault 21:Internal interference-main clock etc 22:PID provide lost 23:PID feedback lost 24:PID error value abnormal 25:Terminal protection activate 26:Communication fault 27~29:Reserved 30:E ² ROM read-write error 31:Temperature detection disconnection	1	0	*

6 Function parameter schedule graph

		32:Auto-tuning fault 33:Reserved 34:Factory fault 1 35:Factory fault 2 36:Capacitor overheat (Few mode with overheat protection) 37:Reserved 38:Over-speed protection 39:Protection when speed deviation is too large 40:Reserved 41:Analog channel disconnected protection 42: Water shortage fault 43: Model code does not match the machine fault 44~50: Reserved			
F26.01	The last two fault records	Same as above	1	0	*
F26.02	The last three fault records	Same as above	1	0	*
F26.03	The last four fault records	Same as above	1	0	*
F26.04	Setup frequency at the last one fault	0.00Hz~upper limit frequency	0.01Hz	0.00Hz	*
F26.05	Output frequency at the last one fault	0.00Hz~upper limit frequency	0.01Hz	0.00Hz	*
F26.06	Output current at the last one fault	0.0~6553.5A	0.1A	0.0A	*
F26.07	DC busbar voltage at the last one fault	0.0~6553.5V	0.1V	0.0V	*
F26.08	Module temperature at the last one fault	0~125°C	1°C	0°C	*
F26.09	Input terminal status at the last one fault			0	*
F26.10	Accumulated run time at the last one fault	0~65535min	1min	0min	*
F26.11	Setup frequency at the last two	0.00Hz~upper limit frequency	0.01Hz	0.00Hz	*

6 Function parameter schedule graph

	fault				
F26.12	Output frequency at the last two fault	0.00Hz~upper limit frequency	0.01Hz	0.00Hz	*
F26.13	Output current at the last two fault	0.0~6553.5A	0.1A	0.0A	*
F26.14	DC busbar voltage at the last two fault	0.0~6553.5V	0.1V	0.0V	*
F26.15	Module temperature at the last two fault	0~125°C	1°C	0°C	*
F26.16	Input terminal status at the last two fault			0	*
F26.17	Accumulated run time at the last two fault	0~65535min	1min	0min	*

F27-Password and Manufacturer Function Parameter Group

Function Code	Name	Set Range	Min. Unit	Factory Default	Modification
F27.00	User password	00000~65535	1	00000	○
F27.01	Manufacturer password	00000~65535	1	00000	○

(1) Corresponding relationship of input terminal status as below:

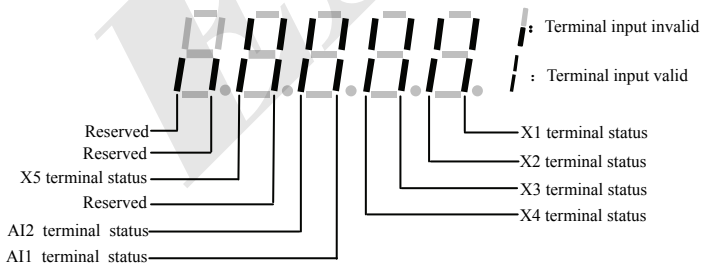

(2) Corresponding relationship of standard output terminal status as below:

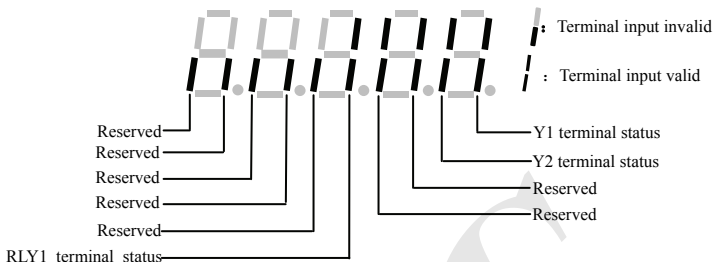

(3) Corresponding relationship of communication virtual input terminal status as below:

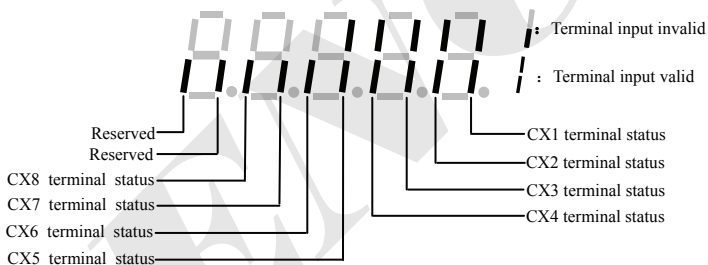

(4) Drive status:

BIT0:1=Busbar voltage setup

BIT2:1=Jog run command valid

BIT4:1=Current run direction to reverse

BIT6:1=Deceleration brake period

BIT8:1=Motor deceleration period

BIT10:1= Drive fault

BIT12:1= Fault self-recovery period

BIT14:1= Free halt status

BIT1:1=Common run command valid

BIT3:1=Drive run period

BIT5:1=Run command direction to reverse

BIT7:1=Motor acceleration period

BIT9:1= Drive alarm

BIT11:1= Current limited period

BIT13:1= Self-adjusting period

BIT15:1= Speed tracking start

7 Detailed function specification

The parameter function code of this chapter listed content as below:

Code No.	Description	Setup Range/Explanation	Factory Default
----------	-------------	-------------------------	-----------------

7.1 System Parameter Group: F00

F00.00	Parameter group display control	Range: 0~4	2
--------	---------------------------------	------------	---

0: Basic list mode. Display only F00, F01, F02, F03 basic control parameter group and F26 fault record parameter group.

1: Middle list mode. Display all parameter except for extension: virtual and reserve parameter group.

2: Senior list mode. All parameter groups can be displayed.

3: User list mode. Display parameter defined by user: and monitor parameter: F00.00 display all the time.

4: Parameter verification mode. In this mode, only the parameter items that are inconsistent with the default values are displayed (The parameter calibration range is F00 to F25. After entering the calibration mode, you can use the UP DW key to view the modified parameters, and you can also enter the specified parameters. If you modify the parameter value again, the SHIFT key is invalid during the parameter review. Note that F00.00 and F03.02 are special parameters in the calibration mode and will always be displayed.



Note

F00.00 display all the time. Under intermediate menu mode: irrelevant parameter group can be covered according to different control mode.

F00.01	C-00 display parameter selection when operation	Range: 0~75	51
F00.02	C-01 display parameter selection when operation	Range: 0~75	2
F00.03	C-02 display parameter selection when operation	Range: 0~75	4
F00.04	C-03 display parameter selection when operation	Range: 0~75	5
F00.05	C-04 display parameter selection when operation	Range: 0~75	6
F00.06	C-05 display parameter selection	Range: 0~75	9

when operation		
----------------	--	--

The above parameter display when inverter run by C-00~C-05 parameter groups, pressing to $\langle \gg \rangle$ switch between these parameters. Pressing $\langle \text{ENTER DATE} \rangle$ and then return to C-00 parameter monitor. For example: pressing $\langle \gg \rangle$ parameter switch from C-00 to C-01: continuous pressing the same button: parameter switch from C-01 to C-02: then pressing $\langle \text{ENTER DATE} \rangle$ return to C-00 parameter monitor.

0: Main setup frequency (0.01Hz)

1: Auxiliary setup frequency (0.01Hz)

2: Setup frequency (0.01Hz)

3: Output synchronization frequency (0.01Hz)

4: Output current (0.1A) (Display 0.01A below 11KW)

5: Output voltage (1V)

6: DC busbar voltage (0.1V)

7: Motor speed (1 circle/min)

8: Motor line velocity (1 circle/min)

9: Inverter temperature (1°C)

10: Run time already this time (0.1min)

11: Current accumulate run time (1h)

12: Current accumulate power-on time (1h)

13: Inverter status (Displays the working state of inverter, show it with decimalism, after change it into binary, The definition is on the parameter details.)

14: Input terminal status

15: Output terminal status

16, 17: Reserved

18: Communication virtual input terminal status

19: Internal virtual input node status

20: Analog input AI1 (After calibration) (0.01V)

21: Analog input AI2 (After checkout) (0.01V/0.01mA)

22, 23: Reserved

24: Analog AO1 output (After checkout) (0.01V/0.01mA)

25, 26, 27: Reserved

28: External pulse input frequency (Before correction) (1Hz)

29: Reserved

30: Process PID provide (0.01V)

31: Process PID feedback (0.01V)

32: Process PID deviation (0.01V)





33: Process PID output (0.01Hz)

- 34: Simple PLC current segment No.
 35: External multi-speed current segment No.
 36: Constant pressure water supply provide pressure (0.001Mpa)
 37: Constant pressure water supply feedback pressure (0.001Mpa)
 38: Constant pressure water supplies relay status
 39: Current length (m/cm/mm)
 40: Accumulate length (1M)
 41: Current internal count value
 42: Current internal time value (0.1s)
 43: Run command setup channel
 (0: Keyboard 1: Terminal 2: Communication)
 44: Main frequency provide channel
 45: Auxiliary frequency provide channel
 46: Rated current (0.1A)
 47: Rated voltage (1V)
 48: Rated power (0.1KW)
 49: Electric torque limit (0.1% Rated torque of motor)
 50: Brake torque limit (0.1% motor rated torque)
 51: The frequency after deceleration (0.01Hz)
 52: Motor rotor frequency (0.01Hz) (Open loop is estimated frequency)
 53: Present provide torque (Relative to rated torque, it has direction)
 54: Present output torque (Relative to rated torque, it has direction)
 55: Present torque current (0.1A)
 56: The present flux current (0.1A)
 57: Setting motor rotate speed (R/Min)
 58: Output power (Active power) (0.1KW)
 59: Low order total power consumption (1kwh)
 60: High order total power consumption (1 represents 10000 kwh)
 61, 62: Reserved
 63: Basic PLC total setting time (1s or 1min)
 64: Basic PLC elapsed time (1s or 1min)
 65: Basic PLC remaining running time (1s or 1min)
 66: The dedicated display mode for constant pressure water supply (SP-PV)
 (kg/cm²)
 67~75: Reserved

F00.07	C-00 display parameter selection when stop	Range: 0~75	2
--------	--	-------------	---

7 Detailed function specification

F00.08	C-01 display parameter selection when stop	Range: 0~75	6
F00.09	C-02 display parameter selection when stop	Range: 0~75	48
F00.10	C-03 display parameter selection when stop	Range: 0~75	14
F00.11	C-04 display parameter selection when stop	Range: 0~75	20
F00.12	C-05 display parameter selection when stop	Range: 0~75	9

The above parameter display when inverter stop by C-00~C-05 parameter group, pressing to  switch between these parameters. Pressing  and then return to C-00 parameter monitor. For example: pressing  parameter switch from C-00 to C-01, continuous pressing the same button: parameter switch from C-01 to C-02: then pressing  return to C-00 parameter monitor. Monitor contents various as different monitor parameter: refer to parameter F00.01.



Note

Monitor parameter group C-00~C-05 have run and stop modes. For example C-00 display different physical value under run and stop two modes.

F00.13	Power-on fault monitor parameter selection	Range: 0~5	0
--------	--	------------	---

When the parameter power on first time: C monitor parameter group display under drive run or stop status, For example F00.13=1, power on or stop to monitor, display parameter setup by C-01; when F00.02=3, F00.08=6, power on, inverter stops, busbar voltage display; inverter runs, output frequency and keypad display. Pressing  monitor C-00 for the setting motor value.

F00.14	Parameter operation control	Range: Units digit: 0~2 Tens digit: 0~5 Hundreds digit: 0~5	000
--------	-----------------------------	---	-----

Units digit: To define which parameters will be allowed to modify.

0: All parameters are allowed to modification.

1: Except this parameter, The other parameter is not allowed to modification.

2: Except F01.01, F01.04 and this parameter, The others parameter are not allowed to modification.

Tens digit: To define which parameters will be resumed factory default value

0: No action.

1: All parameters return to default. (Not include fault record parameter group (F26 Group) parameter).

2: Except for motor parameter: all parameters return to default. (Not include F15 and F26 group parameter).

3: Extension parameter return to default. (Only F21~F24 group parameter return to default).

4: Virtual parameter return to default. (Only F20 group parameter return to default).



5: Fault record return to default. (Only fault record parameter group (F26 group) restores factory default).



Hundreds digit: Locked key that definite the keypad when locking function is valid.

0: All locked.

1: Except  button: The others locked.

2: Except  ,  button: The others locked

3: Except ,  button: The others locked

4: Except ,  button: The others locked



5: Invalid lock



Note

(1) In factory status, the unit of this function code parameter is 0, and it is default and allowed to change all the other function code parameters: when user finish: and want to change the function code setup: this function code parameter should set up 0 first. When all changes finish and need to do parameter protect: this function code setup into the IP grade you need.

(2) The decade recovers to 0 automatically after record remove or factory default operation.

(3) The default value of the hundred digit is 5, It is invalid for locking. If the user has modified the hundred digit value of parameter F00.14, You have to press the  Button over 5 seconds to lock the keypad, and then the related keypad button will be locked. If the user want to unlock the keypad, you must press the  button over 5 seconds to unlock it.

F00.15	Button function selection	Range: Units digit: 0,1 Tens digit: 0~9 Hundreds digit: 0,1 Thousands digit: 0,1	0011
--------	---------------------------	---	------

Units digit: Panel  button selection

0: Reversal command action button

1: Jog action button

Tens digit: Multi-function  button function selection

0: Invalid.

1: Jog run. Multi-function button as jog run button: run direction decided by

unit bit of F01.16.

2: For/Rev switching. Press this button to change the run direction when run; then press the same button change to another direction. This function key is not used as start key, only for signal switch

3: Free stop. Setup free stop function and stop mode F02.11 the same function with 1 Jog run.

4: Switching to run command provide mode as the setup order of F00.16.

5: For/Rev torque switching. After this function is valid, it can realize the direction switching after torque model.

6: Reverse command key. (This key is used as a reverse operation key)

7~9: Reserved

Hundredth: Terminal run command control

0: Keypad  is invalid.

1: Keypad  is valid.

Thousandth: Communication run command control

0: Keypad  is invalid.

1: Keypad  is valid.

F00.16	Multi-function key run command channel switching order selection	Range: 0~3	0
--------	--	------------	---

0: Keyboard control → Terminal control → communication control

1: Keyboard control ↔ terminal control

2: Keyboard control ↔ communication control

3: Terminal control ↔ communication control

These parameters cooperate with multi-function key to run command channel switching function: with special switch to command channel switching order.



Note

(1) Command channel priority terminal switch to (Terminal function code 49, 50, 51) → terminal run command channel selection (Terminal function code 52, 53) → multi-function key switch → F01.15, when switching to terminal control, be sure the terminal command invalid. Terminal switch to and terminal run command channel selection refer to F08 group parameter about the detailed description of terminal function.

(2) We suggest alter the mode at the stop state.

F00.17	Motor speed display coefficient	Range: 0.1~999.9%	100.0%
--------	---------------------------------	-------------------	--------

This function code is used to check speed scale display error, There is no effect to motor actual speed.

F00.18	Line velocity display coefficient	Range: 0.1~999.9%	1.0%
---------------	--	--------------------------	-------------

This function code is used to check speed scale display error, There is no effect to motor actual speed.

F00.19	Reserved		
---------------	-----------------	--	--

F00.20	Analog input terminal configuration	Range: Units digit: Reserved Tens digit: 0,1,2 Hundreds digit: Reserved Thousands digit: Reserved	0000
---------------	--	--	-------------

Through this parameter, can configure whether the analog input AI2 is a current input or a voltage input type. When selecting different types of current and voltage signals, insert the corresponding jumper caps on the control board to the corresponding positions.

Units digit: Reserved

Tens digit: AI2 configuration

0: 0~10V voltage input

1: 0~20mA current input

2: 4~20mA current input

Hundreds digit: Reserved

Thousands digit: Reserved



Note

When configuring AI2, insert the jumper cap on the lower left end of the CPU board to the corresponding position.

F00.21	Analog output terminal configuration	Range: Units digit: 0,1 Tens digit: Reserved Hundreds digit: Reserved Thousands digit: Reserved	0000
---------------	---	--	-------------

Through this parameter, can configure the AO1 analog signal output voltage or current type. When selecting different types of current and voltage signals, insert the corresponding jumper caps on the control board to the corresponding positions.

Units digit: AO1 configuration

0:0~10V voltage output

1:0~20mA current output

Tens, hundreds, thousands digit: Reserved



Note

When configuring AO1, insert the jumper cap on the lower left end of the CPU board to the corresponding position.

7 Detailed function specification

F00.22	Y output terminal configuration	Range: Units digit: Reserved Tens digit: Reserved Hundreds digit: Reserved Thousands digit: 0,1	0000
---------------	--	--	-------------

Units digit ~ Hundreds digit: Reserved
Thousands digit: Y2 output configuration

0: Open collector output
 1: DO output

The thousands digit decide the Y2 output terminal type, when 0 means open collector output, when 1 means high speed pulse DO output.

F00.23	Inverter type	Range: 0, 1	0
---------------	----------------------	--------------------	----------

0: Heavy load, set the inverter to heavy load type, suitable for mechanical and constant torque loads.

1: Light load, set the inverter to light load type, which is suitable for fans and pumps that are square or cubic torque off load.

F00.24	Motor control model	Range: 0,1	0
---------------	----------------------------	-------------------	----------

0: V/F control (Torque control is not supported).

When it is necessary to start fan, water pump load or a single inverter to start more than one motors, please select the V/F control mode.

1: Speedless sensor vector control

The speedless sensor vector control operation mode is mainly used for speed control, torque control and other places that require high control performance, such as machine tools, centrifuges, and wire drawing machines. In order to obtain better control performance, it is necessary to set the F15 motor parameter group according to the motor nameplate (F15.00 to F15.06), and perform motor parameter self-learning. In vector control, one inverter can only drive one motor, and the power of the inverter needs to match the motor. Generally, the inverter is allowed to be one to two gears larger than the motor. It is recommended to use F00.24=1 (speedless sensor vector control) when driving synchronous motors.

F00.25	Reserved		
---------------	-----------------	--	--

F00.26	Busbar voltage adjustment	Range : 0.900~1.100	1.000
---------------	----------------------------------	----------------------------	--------------

The bus voltage can be adjusted through this parameter to make the inverter bus voltage detection consistent with the actual situation. It will be more accurate to calibrate the bus voltage when the inverter is running.

F00.27	Parameter copying and language selection	Range: Units digit: Reserved Tens digit: 0~3	00
---------------	---	---	-----------

Units digit: Reserved

Tens digit: Parameter upload and download (Only external keyboard is

valid)

0: No action

1: Parameter upload

2: Parameter download 1 (Without motor parameter)

3: Parameter download 2 (With motor parameter)

When all motors carried by inverters are the same type in one system, we can use parameters download 1. Otherwise, use the parameters download 2.

F00.28	Output power display calibration parameters	Range: 20%~300%	100%
--------	---	-----------------	------

Adjustment factor for output power (Monitoring item No.58).

F00.29 ~ F00.60	Reserved		
-----------------------	----------	--	--

F00.61	The fault type of the current fault	Range: 0~65535	0
--------	-------------------------------------	----------------	---



When part of the fault occurs, you can use the F00.61 parameter to further understand the type of the fault, which is used to determine the source of the fault. For details, see the fault description chapter.

F00.62 ~ F00.70	Reserved		
-----------------------	----------	--	--

7.2 Basic Run Function Parameter Group: F01

F01.00	Main frequency input channel selection	Range: 0~14	0
--------	--	-------------	---

Total 15 types input channel for selection to chose inverter input channel of the main provide frequency.

0:Operation keyboard digital setup. When main frequency setup initial value to F01.01, modify F01.01 parameter to change main setting frequency with operation keyboard: or with  ,  button to modify the value of F01.01

1: AI1 analog setting. The main frequency setting is determined by AI1 analog voltage, and the input range is 0~10V.

2: AI2 analog setup. Main frequency setup confirmed by AI2 analog voltage/current, input range: 0~10V (AI2 jumper wire selection V side) or 0~20mA (AI2 jumper wire selection A side).

3:Terminal UP/DOWN adjusting setup. When main frequency initial value is parameter F01.01, through terminal UP/DOWN function to adjust the main setting frequency. Terminal function setup into 16 (Frequency increase progressively (UP)) or 17 (frequency decrease progressively control (DOWN)).

4:Communication provide (Communication address:1E01). The initial

value of the main frequency is the value of parameter F01.01, which is given by the communication mode selected by F05.00.

5,6: Reserved

7: High speed pulse setup. main frequency setup by frequency signal of terminal pulse (only X5 input), input pulse specification: voltage range 15~30V; frequency range 0.00~20.00KHz.

8: Terminal pulse setup. main frequency setup by pulse width signal of terminal pulse (only X5 input), input pulse specification: voltage range 15~30V; pulse width range 0.1~999.9ms.

9: Terminal encoder setup. main frequency setup by terminal encoder pulse (only combination input by X1 and X2) and frequency velocity set by parameter F08.30.

10~14: Reserved



Note

When PID operation is valid, the operation mode is completely determined by PID error polarity and F11.21.



Excerpt terminal encoder provide (F01.00=9), main and auxiliary provide channel cannot be set into the same frequency source: if they are the same: then panel would be light (ALM) and display A-51.

F01.01	Main frequency digital setup	Range: 0.00Hz~upper limit frequency	50.00Hz
--------	------------------------------	-------------------------------------	---------

When F01.00=0,3 or 4, F01.01 is the initial value of main frequency.

F01.02	Main frequency digital control	Range: 00~111	000
--------	--------------------------------	---------------	-----

Units digit: Power down reserve setup

0: Main frequency power down reserve. When main frequency channel provide is valid, power down in run status, current main frequency of run frequency is recorded in parameter F01.01.

1: Main frequency power down no reserve.

Tens digit: Halt reserve setup

0: Halt main frequency hold. When main frequency channel provide is valid, current run frequency only recorded after halt.

1: Halt main frequency recovery F01.01. main setting frequency recorded in software is recovery to value of parameter F01.01 after halt.

Hundreds digit: Set of communication presetting frequency dimension. (It is valid for both main and slave frequency communication presetting)

0: Preset of absolute frequency mode (Preset 5000 represent 50.00Hz).



1: Preset 10000 represent upper limit frequency (F01.11).

**Note**

Only when parameter F01.00=0, 3, 4, it can be valid, after power-fail or Stop storage function both are valid, stop the machine first, it also can serve.

F01.03	Auxiliary frequency input channel select	Range : 0~20	20
---------------	---	---------------------	-----------

VFD auxiliary provides frequency input channel has 21 input channels for selection, for them 11~20 are Reserved channels, and currently there is no relevant function:

0: Keyboard operation digital setup. When auxiliary frequency setup initial value is parameter F01.04, modify parameter F01.04 to change auxiliary setting frequency: or with ,  button modify the value of parameter F01.04

1: AI1 analog setting. Auxiliary frequency setting is determined by AI1 analog voltage, input range: 0~10V.

2: AI2 analog setup. Auxiliary frequency setup confirmed by AI2 analog voltage/current, input range: 0~10V (AI2 jumper wire selection V side) or 0~20mA (AI2 jumper wire selection A side).

3: Terminal UP/DOWN adjusting setup. Auxiliary frequency initial value is parameter F01.04, through terminal UP/DOWN function to adjust auxiliary setting frequency.

4: Communication provide (Communication address:1E01). The initial value of auxiliary frequency is for F01.04, it will determine by F05.00 of the communication setting.

5,6: Reserved.

7: High speed pulse setup. Auxiliary frequency setup by frequency signal of terminal pulse (only X5 input), input pulse specification: voltage range 15~30V; frequency range 0.00~20.00 kHz.

8: Terminal pulse width setup. Auxiliary frequency setup by pulse width signal of terminal pulse (only X5 input), input pulse specification: voltage range 15~30V; pulse width range 0.1~999.9ms.

9: Terminal encoder provide. Auxiliary frequency setup by terminal encoder pulse (only X3 or X4 input), 0.01Hz is a fixed adjusting precision.

10: Reserved.

11: Process PID Setting. Through the main frequency setting and the auxiliary frequency setting, can realize PID with feed forward control, which can make the system be into a steady state quickly. Generally, it is used in the scene of the process closed loop control, such as constant pressure closed loop control, constant tension closed-loop control, etc.

12~20: Reserved.



Except terminal encoder provide (F01.03=9), main and auxiliary provide channel cannot setup to the same frequency source, when they are the same, then panel light (ALM), and A-51 display.

F01.04	Auxiliary frequency digital setup	Range: 0.00Hz~upper limit frequency	0.00Hz
--------	-----------------------------------	-------------------------------------	--------

When F01.03=0, 3 or 4, F01.04 is the initial frequency value of auxiliary frequency.

F01.05	Auxiliary frequency digital control	Range: Units digit: 0,1 Tens digit: 0,1	11
--------	-------------------------------------	--	----

Units digit: Power down reserve setup

0: Auxiliary frequency power down reserve. When auxiliary frequency channel provide is valid and power down at run mode, the current auxiliary setting frequency reserve in parameter F01.04.

1: Auxiliary frequency power down no reserve.

Tens digit: Halt reserve setup

0: Halt auxiliary frequency hold. When auxiliary frequency channel provide is valid, recording current run frequency only after halt.

1: Halt auxiliary frequency recovery parameter F01.04. auxiliary setting frequency in software recording is recovered the value of parameter F01.04 after halt.



Only when F01.03=0,3,4 is valid.

Note

F01.06	Main and auxiliary provide calculating setup	Range: 0~8	0
--------	--	------------	---

This parameter is to select frequency provide channel: and through the complex of main frequency source and auxiliary frequency source to achieve frequency provide.

0: BMain frequency. Complex frequency of current is main frequency.

1: Auxiliary frequency. Complex frequency of current is auxiliary frequency.

2: Plus (Polarity oppose of complex and main frequency, complex frequency is zero).

3: Minus (Polarity oppose of complex and auxiliary frequency, complex frequency is zero).

4: Multiplication (Polarity opposed of main and auxiliary frequency: complex frequency is zero).

5: Max (The max frequency of main and auxiliary absolute value).

6: Min (The min frequency of main and auxiliary absolute value).

7: Selection no-zero value (Auxiliary is not negative, main frequency prior; auxiliary is negative, complex frequency is zero)

8: Main frequency × Auxiliary frequency × 2 / F01.11. (Polarity opposed of main and auxiliary frequency complex frequency is zero, can realize the fine tuning based on the main frequency).



Note

(1) The initial polarity of main and auxiliary frequency cannot change after main and auxiliary operation.

(2) When main and auxiliary frequency channel are complex value, and both setup into power down reserve: parameter F01.01 and F01.04 reserve separately the changed part of main frequency and auxiliary frequency in the complex frequency when power down.

F01.07	Auxiliary frequency provide coefficient	Range : 0.00~10.00	1.00
--------	---	--------------------	------

Parameter F01.07 can adjust auxiliary provide frequency gain.

F01.08	Coefficient after complex of main and auxiliary frequency	Range: 0.00~10.00	1.00
--------	---	-------------------	------

This parameter is to setup frequency flexibly and calculates the gain of complex setting frequency by main and auxiliary frequency.

F01.09	Auxiliary frequency range selection	Range: 0, 1	0
--------	-------------------------------------	-------------	---

0:Relative high limit frequency. Auxiliary frequency setup range: 0.00Hz~high limit frequency×F01.10.

1:Relative main frequency. Auxiliary frequency setup range: 0.00Hz~main frequency×F01.10.

F01.10	Auxiliary frequency source scope	Range: 0.00~1.00	1.00
--------	----------------------------------	------------------	------

This parameter cooperate with F01.09 define the scope of auxiliary provide frequency. Auxiliary provide frequency high limit value is restrained by the frequency selected by parameter F01.09 through parameter F01.10 gain calculation.

F01.11	Upper limit frequency	Range: Lower limit Frequency~600.00Hz	50.00Hz
--------	-----------------------	---------------------------------------	---------

This parameter's max setting frequency of all run modes should be modification carefully according to the motor nameplate details.

F01.12	Low limit frequency	Range: 0.00Hz~upper limit frequency	0.40Hz
F01.13	Low limit frequency run mode	Range : 0~3	2
F01.14	Sleep run hysteresis frequency	Range: 0.01Hz~upper limit frequency	0.01Hz

- 0: As low limit frequency run.**
- 1: As setting frequency run.**
- 2: As zero frequency run.**
- 3: Sleep: PWM clocked at sleep mode.**





When actual setting frequency lower than low limit frequency, low limit frequency run mode selection 0, Then drive run at low limit frequency; low limit frequency run mode selection 1,drive continuously run according to setting frequency; low limit frequency run mode selection 2, drive continuously low output frequency and run at zero frequency; If the lower limit frequency operation mode is selected as 3 and the current operation frequency is also lower than F01.12, the output will be immediately blocked and enter the shutdown state. At the moment, when the given value exceeds the lower limit frequency and after the hysteresis of F01.14, it starts to accelerate from 0Hz to the given value again.



Note

When F01.13=3, this parameter can finish sleep function to achieve energy saving run and avoid drive to start frequently at threshold value through width of return difference.

F01.15	Run command channel selection	Range: 0~2	0
--------	-------------------------------	------------	---

0: Operate the keyboard to run control. Use the  ,  ,  (External keyboard),  keys on the keyboard to start and stop, and use the external keyboard to achieve dual keyboard control.

1: Terminal running command control. In the function code settings of X1~X5 and A11, A12, X1 is the forward (FWD) terminal and X2 is the reverse (REV) terminal by default. Can also choose other terminals as the forward and reverse input terminals.

2: Communication runs command control. Start and stop with communication mode.



(1) Drive can change run command channel through switch of multi-function key,terminal command channel in halt and run,carefully modify command channel after confirm in site the permission to run command channel modification. After the command channel modification: keyboard  button setup valid or not by parameter F00.15.

(2) After run command channel modification,frequency channel can be defined by parameter F18.00,F18.01,F18.02 .or defined by parameter F01.00,F01.03,F01.06 and multi-function terminal.

F01.16	Run direction setup	Range: Units digit: 0,1 Tens digit: 0~2 Hundreds digit: 0,1 Thousands digit: 0,1	1000
--------	---------------------	---	------

Units digit: Keyboard command For/Rev setup (Only valid to keyboard inching command)

0: Forward.

1: Reverse.

Tens digit: For/Rev forbid (Suitable for all command channel, not include inching function)

0: For/Rev available.

1: Reverse not available (Imposing on reverse, stop as the halt mode).

2: Forward not available (Imposing on forward, stop as the halt mode).

Hundreds digit: Reverse running direction (Only valid for keyboard and communication channel)

0: Invalid

1: Valid. It can achieve the adjustment of the motor running direction without adjusting the UVW wiring sequence.

Note: Under the condition that realize multi-section speed control by the PLC or terminal, if the tens of F10.01 to F10.15 is equal to 0 or 1, the direction of motor running is not affected by this parameter.

Thousands digit: Terminal multi-section speed acceleration and deceleration time control

0: Corresponding to acceleration and deceleration 1~15 (F01.17, F01.18, F04.16~F04.43) respectively.

1: Determined by F01.17 and F01.18

Note: When F01.16 thousands digit is 0, the acceleration and deceleration time after stopping operation or removing the multi-speed terminal under multi-speed valid is determined by the corresponding acceleration and deceleration time of the multi-speed before cancellation.

F01.17	Acceleration time 1	Range: 1~60000	Depend on type
F01.18	Deceleration time 1	Range: 1~60000	Depend on type

Acceleration time is interval accelerate from zero frequency to high limit frequency, deceleration time is the interval decelerate from high limit frequency to zero frequency. The unit defined by F01.19. Example: F01.17=100, F01.19=1, acceleration time 1 is 10.0 seconds.



Note

(1) ENA100 series drive defines 15 acceleration and deceleration time, only acceleration and deceleration time 1 defined here, acceleration and deceleration 2~15 defined in parameter F04.16~F04.43.

(2) Acceleration and deceleration 1~15 select time unit through parameter F01.19, factory default unit is 0.1 second.

F01.19	Accelerate/decelerate time unit	Range: 0~2	1
--------	---------------------------------	------------	---

This function can define acceleration and deceleration time unit.

0:0.01s

1:0.1s

2:1s



Note

(1) The function is valid to all acceleration and deceleration except for inching run.

(2) Advise to select 0.1s as the time unit.

F01.20	Accelerate/decelerate mode selection	Range: 0, 1	0
--------	--------------------------------------	-------------	---

0: Line Acc/Dec mode. Output frequency raises or declines as the constant slope, as Fig.7-1.

1: S curve Acc/Dec mode. Output frequency raise or decline as the S curve: as Fig.7-2.

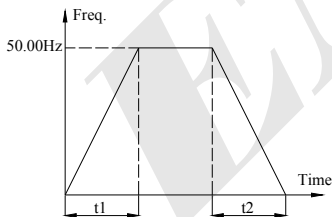

Fig. 7-1 Line acc/dec

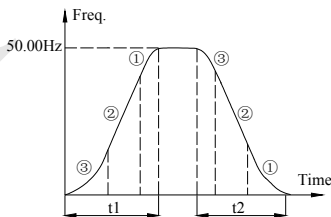

Fig. 7-2 S curve acc/dec

F01.21	S curve acceleration initiation segment time	Range: 10.0%~50.0%	20.0%
F01.22	S curve acceleration up segment time	Range: 10.0%~70.0%	60.0%
F01.23	S curve deceleration initiation segment time	Range: 10.0%~50.0%	20.0%

F01.24	S curve deceleration up segment time	Range: 10.0%~70.0%	60.0%
---------------	---	---------------------------	--------------

F01.21~F01.24 select S curve acceleration and deceleration mode (F01.20=1) valid only under acceleration and deceleration, and $F01.21+F01.22 \leq 90\%$, $F01.23 + F01.24 \leq 90\%$.

S curve starts interval time as Fig.7-2 ③, output frequency changed slope increase slowly from zero.

S curve up interval time as Fig.7-2 ②, output frequency changed slope is constant.

S curve ends interval time as Fig.7-2 ①, output frequency changed slope decrease slowly to zero.



Note

S curve acc/dece mode is suitable for the start and stop of elevator, conveyor belt, transport and transfer load so on.

F01.25	Keyboard jog run frequency	Range:0.00Hz~upper limit frequency	5.00Hz
F01.26	Terminal jog run frequency	Range:0.00Hz~upper limit frequency	5.00Hz
F01.27	Jog interval time	Range: 0.0~100.0s	0.0s
F01.28	Jog acceleration time	Range: 0.1~6000.0s	20.0s
F01.29	Jog deceleration time	Range: 0.1~6000.0s	20.0s

F01.25, F1.26 defines keyboard jog and terminal jog run frequency, when jog run: accelerate as the zero frequency, and not effect by the start mode defined by parameter F02.00. When jog command revocation, stop as setting halt mode, when input another command during the deceleration, accelerate or decelerate according to the current frequency.

F01.27 defies valid command interval time at continuously jog. When jog command invalid, the time restart jog command is short than jog interval time, jog command ignore here.

F01.28, F01.29 defines jog run acceleration and deceleration time, fixed unit is 1s.

F01.30	Reserved		
F01.31	Reserved		

7.3 Start, Stop, Forward/Reverse, Brake function parameter group: F02

F02.00	Start running mode	Range: 0~2	0
--------	--------------------	------------	---

0: Start from starting frequency. After receiving start command by setting F02.01 delay time, the inverter starts after setting F02.02 starting frequency and F02.03 starting frequency duration.

1: First brake, and then start from starting frequency. First brake the current from DC and then from time (F02.04, F02.05), and then start after setting starting frequency and starting frequency duration set by F02.03.

2: Speed tracking starts. Currently this start mode only supports asynchronous motor V/F or SVC control.



(1) Start-up mode 0: It is suggested to use Start-up mode 0 for general purpose applications and for general drive synchronous motor.

(2) Start-up mode 1: Suitable for small inertia load, for example, forward and reverse occurs when the motor is not driven.

(3) Start-up mode 2: Suitable for the starting of large inertia load before stopping stably. Generally this mode is used when restarting after power failure, fault self-recovery and other functions. The following points need to be noticed when this Start-up mode is used:

- ① When the inverter stops freely, restart the inverter after a few seconds. If over-current fault occurs when starting, please extend the F02.08 time.
- ② Do not modify the set frequency when the inverter starts in slow down process.
- (4) When torque model is valid, we suggest use the start mode 2.

F02.01	Starting delay time	Range: 0.0~60.0s	0.0s
--------	---------------------	------------------	------

The start delay time refers to the time in the waiting state before the inverter starts after receiving the run command. There is no change in the waiting state before and after receiving the run command.

F02.02	Starting frequency	Range: 0.0~10.00Hz	0.00Hz
F02.03	Starting frequency duration time	Range: 0.0~60.0s	0.0s

Starting frequency refers to the initial frequency when the inverter is started, as shown in Fig.7-3 f_s ; starting frequency holding time refers to consecutive running time during which the inverter runs at the starting frequency, as shown in Fig.7-3 t_1 .

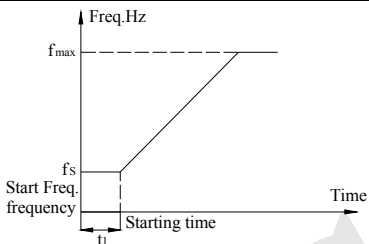

Fig. 7-3 Starting frequency and starting time



Starting frequency is not limited by lower limit frequency.

Note

F02.04	DC braking current when starting	Range: 0.0 ~ 100.0% (G type inverter rated current)	30.0%
F02.05	DC braking time when starting	Range: 0.0~30.0s	0.0s

When F02.00=1, F02.04, F02.05 valid, and stop mode is deceleration stop, as shown in Fig.7-4.

The setting of starting DC braking current is with respect to the percentage of inverter rated output current. When starting DC braking time is 0.0 second, no DC braking process.

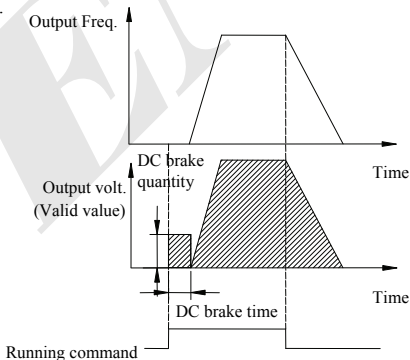

Fig. 7-4 Starting mode 1 description

F02.06	Speed track starting frequency selection	Range: 0~2	2
--------	--	------------	---

0: Current setting frequency.

1: Running frequency before power down.

2: Speed track auxiliary starting frequency.

Select frequency closed to the current running frequency of the motor so as to track the current running revolving speed of the motor. For example, when current running frequency is closed to current setting frequency, then select 0 and start to search from current setting frequency. This parameter is valid in V/F control mode.

F02.07	Speed track auxiliary starting frequency	Range:0.00Hz~upper limit frequency	30.00Hz
--------	--	------------------------------------	---------

This parameter defines when 2 is selected in F02.06 parameter, the starting searching frequency when revolving track is started.

F02.08	Speed track starting waiting time	Range: 0.00~10.00s	0.10s
--------	-----------------------------------	--------------------	-------

When 2 is selected in F02.00, if the inverter checks that the running command is valid, the revolving speed is searched after the time defined by F2.08.

F02.09	Speed track current control coefficient	Range: 1~20	2
--------	---	-------------	---

This parameter define the speed search process tracking current, the bigger of the value, the faster it can track.

F02.10	Speed track searching speed time	Range: 0.1~30.0	4.00
--------	----------------------------------	-----------------	------

This parameter can be modified to improve speed track time.

On SVC control, the minimum unit of speed tracking for search speed time is 0.1s;

On V/F control, the minimum unit of speed tracking for search speed time is 1s.



Note

- (1) F02.06~F02.09 parameter only can be started on the speed variator, The start is valid.
- (2) F02.10 parameter can be used for both V/F model and SVC model.

F02.11	Stop mode	Range: 0~2	0
--------	-----------	------------	---

0: Deceleration stop. After receiving stop command, the inverter reduces output frequency gradually according to the set deceleration time, the inverter stops when frequency is 0.

1: Free stop. After receiving stop command, the inverter stops output immediately, and the load stops freely according to mechanical inertia.

2: Deceleration + DC braking stop. After receiving stop command, the inverter reduces output frequency gradually according to the set deceleration time. When reaching F02.14 starting frequency of stop braking, After F02.15 defines DC

braking waiting time, the inverter starts DC braking, as shown in Fig.7-5.



Note

When driving the permanent magnet synchronous motor running in torque mode, the stop mode is fixed as free stop, which is not controlled by parameter F02.11.

F02.12	Deceleration stop holding frequency	Range: 0.00Hz~upper limiting frequency	0.00Hz
F02.13	Deceleration stop holding time	Range: 0.00~10.00s	0.00s

The parameters F02.12 and F02.13 define inverter's deceleration stop holding function. When the frequency reaches set value of F02.12 in deceleration, it stops deceleration, and maintains the set time of F02.13, and enters deceleration state. This parameter is only valid for stop mode 0.

F02.14	Stop DC braking starting frequency	Range: 0.00~15.00Hz	0.50Hz
F02.15	Stop DC braking waiting time	Range:0.00~30.00s	0.00s
F02.16	Stop DC braking current	Range: 0.0~100.0% (Motor rated current)	0.0%
F02.17	Stop DC braking time	Range: 0.0~30.0s	0.0s
F02.18	Stop auxiliary braking current	Range: 0.0~100.0% (Motor rated current)	0.0%
F02.19	Stop auxiliary braking time	Range: 0.0~100.0s	0.0s

F02.14 ~ F02.19 parameter defines the current and duration inputting to the motor in the stop DC braking state. If F02.17, F02.19 or F02.14 parameter is 0.0s, then no DC braking process.

Auxiliary DC brake means when the inverter stops DC brake is finished give the second stage DC braking. Role in some special circumstances require rapid braking, and stop long time in the state of DC braking, but to prevent motor heat circumstances.

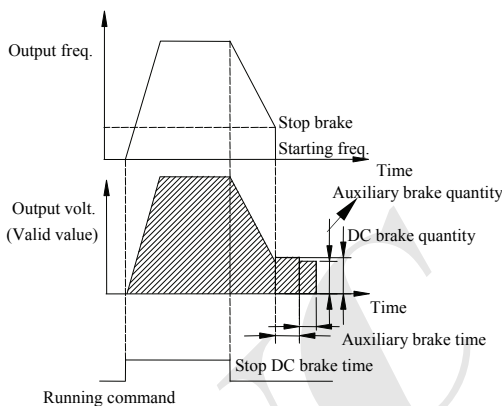

Fig. 7-5 Deceleration stop + DC braking

F02.20	Forward/reverse dead zone time	Range:0.0~3600.0s	0.0s
F02.21	Forward/reverse switching mode	Range: 0, 1	0

0: Over zero switch over

1: Over starting frequency switchover

Forward/Reverse dead zone time refers to the process in which the inverter operates from forward to reverse or from reverse to forward. After output frequency reaches the defined frequency in switchover mode, entering in to the transition time, as shown in Fig. 7-6 t_1 , within transition time t_1 , output frequency is 0Hz.

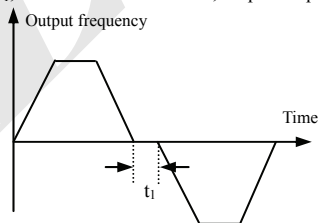

Fig. 7-6 Forward/Reverse dead zone time

F02.22	Energy consumption braking selection	Range: 0~2	0
--------	--------------------------------------	------------	---

0: No energy consumption braking.

1: Energy consumption braking 1 (No braking while halting).

2: Energy consumption braking 2 (Braking while halting). This option can prevent over-voltage fault caused by high busbar voltage during the halting process.



Note

Please set the function parameter correctly according to the actual use condition. Otherwise, control feature will be affected. Before starting this function, make sure the inverter has built-in brake unit and brake resistor.

F02.23	Energy consumption braking voltage	Range:100.0~145.0% (Rated busbar voltage)	125.0%
F02.24	Energy consumption braking use rate	Range:0.0~100.0%	100.0%

Energy consumption braking function is only valid for built-in brake unit. F02.23 defines energy consumption braking busbar voltage threshold value, F02.24 parameter adjusts duty ratio brake unit. The higher the brake use rate is, the greater the brake unit duty ratio is, and the more apparent the brake effect is, but when fluctuation of the brake process busbar voltage is more apparent, user needs to select proper parameter based on brake resistor and brake power.

F02.25	Encryption time	Range:0~65535h	0
--------	-----------------	----------------	---

When F02.25>1, the encryption time is valid .When the running time (F07.12) exceed the time defined by F02.25, the inverter will stop and the keyboard display A-53, the inverter can only start again after decode.

F02.26	Vector control shutdown frequency	Range: 0.20~5.00Hz (Only F00.24=1 is valid)	0.40Hz
--------	-----------------------------------	--	--------

In the vector control deceleration stop mode, especially for the occasion of rapid stop, proper adjustment of this parameter can improve the control stability of deceleration stop.

7.4 V/F control parameter group: F03

F03.00	V/F curve set	Range: 0~5	0
--------	---------------	------------	---

0: Constant torque curve.

1: Decreasing torque curve 1.

2: Decreasing torque curve 2.

3: Decreasing torque curve 3.

4: V/F curve setting (V/F frequency and voltage cannot be 0 or Max. value).

5: V/F Separation control (Voltage channel is determined by F18.22). Torque motor, inverter power supply, induction heating can use this control method.

This function code defines ENA100 flexible V/F setting mode to satisfy

different load characteristics. 4 kinds of fixed curves, one customized curve and V/F separation control can be selected according to definition of F03.00.

When F03.00=0, V/F curve is Constant torque curve feature, as shown in Fig. 7-7a curve 0.

When F03.00=1, V/F curve is 1.2 order power decreasing torque characteristic, as shown in Fig. 7-7a curve 1.

When F03.00=2, V/F curve is 1.7 order power decreasing torque characteristic, as shown in Fig. 7-7a curve 2.

When F03.00=3, V/F curve is 2.0 order power decreasing torque characteristic, as shown in Fig. 7-7a curve 3.

User can choose 1, 2, 3 V/F curve running mode according to load characteristic to reach better energy-saving effect when the inverter drives decreasing torque load such as blower and water pump etc.

When F03.00=4, user can set V/F curve by setting F03.04 ~ F03.11 parameter.

As shown in Fig. 7-7b, V/F curve can be defined freely by setting (V1, F1), (V2, F2), (V3, F3), (V4, F4) to meet special load environment.

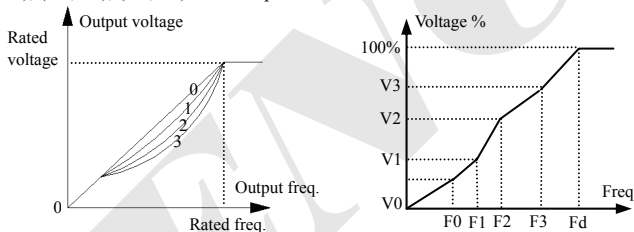

V0~V3: The 1st-4th voltage percentage of multi section V/F

F0~F3: The 1st-4th frequency points of multi section V/F

Fb: Rated frequency

a: V/F curve

b: User-setting V/F curve

Fig. 7-7

F03.01	Torque boost mode	Range: 0, 1	0
--------	-------------------	-------------	---

0: Manual boost. Torque boost voltage is totally decided by parameter F03.02, whose feature is that the boost voltage is fixed, but magnetic saturation of the motor is occurs often to the light-load.

$$\text{Boost voltage} = \frac{F03.02}{100} \times \text{motor rated voltage}$$

1: Auto torque boost. Torque boost voltage changes when the stator current of

the motor changes, the greater the stator current is, magnetic saturation boost voltage is.

$$\text{Boost voltage} = \frac{F03.02}{100} \times \text{motor rated voltage} \times \frac{\text{Inverter output current}}{2 \times \text{Inverter rated current}}$$

F03.02	Torque boost	Range: 0.0~12.0%	Depend on type
F03.03	Torque boost cut-off frequency	Range:0.0~100.0% (Motor rated frequency)	100.0%

Improving inverter low torque characteristic, the output voltage can be compensated.

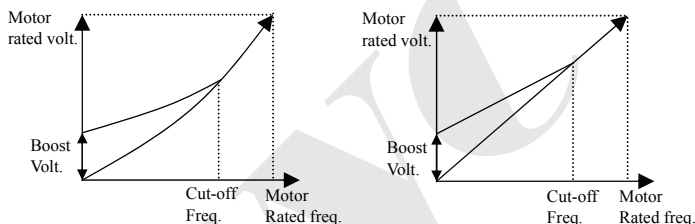

a: Degression torque curve Torque boost

b: Constant torque curve Torque boost

Fig. 7-8 Torque boost



Note

- (1) F03.02 for increasing torque setting to this parameter can cause motor heating or over current protection.
- (2) When driving synchronous machine, User is advised to adopt manual torque boost and adjust V/F curve according to motor parameter and usage occasion when driving synchronous motor.

F03.04	V/F frequency value 0	Range: 0.00~V/F frequency value1	10.00Hz
F03.05	V/F voltage value 0	Range:0.00~V/F voltage value1	20.00%
F03.06	V/F frequency value1	Range: V/F frequency value 0~V/F frequency value2	20.00Hz
F03.07	V/F voltage value1	Range: V/F voltage value0~V/F voltage value2	40.00%
F03.08	V/F frequency value2	Range: V/F frequency value1~V/F frequency value3	25.00Hz

7 Detailed function specification

F03.09	V/F voltage value2	Range: V/F voltage value1~V/F voltage value3	50.00%
F03.10	V/F frequency value3	Range: V/F frequency value2~upper limiting frequency	40.00Hz
F03.11	V/F voltage value3	Range: V/F voltage value2~100.00%(Motor rated voltage)	80.00%

F03.04 ~ F03.11 defines multi-step V/F curve. Note that 4 voltage points and frequency points relationship shall be satisfied: $V_0 < V_1 < V_2 < V_3$, $F_0 < F_1 < F_2 < F_3$, for details, please refer to Fig.7-8b.

If the voltage at low frequency is set too high, motor overheat or even over burning may cause, over current protection may occur to the inverter.

F03.12	V/F oscillation suppression factor	Range: 0~255	10
--------	------------------------------------	--------------	----

Under V/F control, this parameter can be set properly to prevent motor vibration of the motor. When the inverter operates at low frequency without load, the greater the motor power is, the greater the vibration of motor will be. This parameter can be increased to restrain the vibration of motor. When carrier freq. is smaller, this parameter can be adjusted lower to reduce vibration. This parameter needs to be used in conjunction with F18.15, otherwise it may result in failure to suppress oscillation.

7.5 Auxiliary running parameter group: F04

F04.00	Jump freq. 1	Range: 0.00Hz~upper limiting frequency	0.00Hz
F04.01	Jump freq. 1 range	Range: 0.00Hz~upper limiting frequency	0.00Hz
F04.02	Jump freq. 2	Range: 0.00Hz~upper limiting frequency	0.00Hz
F04.03	Jump freq. 2 range	Range: 0.00Hz~upper limiting frequency	0.00Hz
F04.04	Jump freq. 3	Range: 0.00Hz~upper limiting frequency	0.00Hz
F04.05	Jump freq. 3 range	Range: 0.00Hz~upper limiting frequency	0.00Hz

F04.00 ~ F04.05 is set to keep inverter's output frequency away from resonance frequency of mechanical load. Inverter setting frequency can jump around some frequency point according to mode as shown in Fig.7-9, 3 jumping ranges can be defined at most.

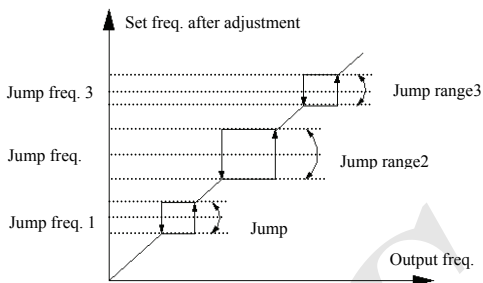

Fig. 7-9 Jump freq. and range

F04.06	Slip freq. gain	Range: 0.0~300.0%	0.0%
F04.07	Slip compensation limit	Range: 0.0~250.0%	100.0%
F04.08	Slip compensation time constant	Range: 0.1~25.0s	2.0s

This function can adjust output frequency properly as the load varies to compensate slip frequency of the asynchronous motor dynamically, so that control motor speed is in constant value. If acting with automatic torque boost function, better low speed moment characteristic can be obtained. As shown in Fig.7-10.

Slip compensation range = Slip compensation limit (F04.07) × Rated slip.

Rated slip = $F15.04 \times 60 / N_p - F15.05$.

N_p is motor polarity.

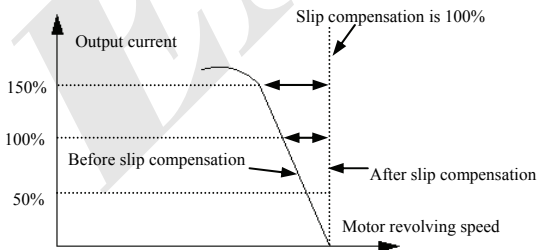

Fig. 7-10 Slip freq. Compensation

F04.09	Carrier frequency	Range: 0.5~16.0K	Depend on type
--------	-------------------	------------------	----------------

Carrier freq. mainly affects motor noise and heat loss when running. Relationship among carrier freq, motor noise, and leak current is as follows:

When carrier freq. goes up (↑), the motor noise is reduced (↓), leakage current of the motor is increased (↑), and the interference is increased (↑);

When carrier freq. goes down (↓), the motor noise is increased (↑), leakage current of the motor is decreased (↓), and the interference is decreased (↓).

When the ambient temperature is high, and the motor load is heavy, reduce the carrier freq. properly to reduce thermal loss to the inverter.

Table7-1 Model and Carrier freq. relationship

Power	Maximum carrier frequency	Factory default
0.4KW~1.5KW	16KHz	4KHz
2.2KW~11KW	16KHz	4KHz
15KW~22KW	8KHz	4KHz
30KW~55KW	8KHz	2KHz
75KW~160KW	6KHz	2KHz



Note

(1) To get better control characteristic, it is suggested that the ratio of max. running frequency between carrier frequency and inverter be not smaller than 36.

(2) Error exists in current displayed value when carrier frequency is small.

F04.10	PWM optimized adjustment	Range: Units digit: 0,1 Tens digit: 0,1 Hundreds digit: 0,1 Thousands digit: Reserved	0010
--------	--------------------------	--	------

Units digit: Carrier freq. is adjusted automatically according to temperature

0: Banned.

1: Allowed.

Carrier frequency changes based on temperature, which refers to inverter check that the radiator temperature is relatively high, it automatically reduces carrier freq., so as to reduce inverter temperature rise. When radiator temperature is relatively low, carrier freq. gradually restores to set value. This function can reduce inverter overheat alarm.

Tens Digit: low speed carrier freq. limit mode

0: No limit.

1: Limit. The carrier is limited at low speed to improve the stability of low-speed. The minimum limit in SVC mode is 2.5KHz; The minimum limit in V/F mode is 0.6KHz.

Hundreds digit: carrier wave modulation system

0: 3 phase modulation.

1: 2 phase and 3 phase modulation.

In some occasions with high ambient temperature, you can try to use two-phase and three-phase debugging to further prevent the inverter from reporting over-temperature faults.

Thousands digit: Reserved



Note

When units digit is set as 1, after reaching overheat warning alarm point, carrier wave will decrease to 1.5KHz; when the temperature decrease to 5°C lower than overheat warning alarm point, carrier freq. will automatically rise to the set carrier freq. When running in SVC mode, When the temperature reaches the pre-overheating alarm point, the minimum drops to only 2.5KHz.

F04.11	AVR function	Range : 0~2	2
--------	--------------	-------------	---

AVR namely automatic voltage regulation function, It indicates that the inverter can output constant voltage by AVR function when the inverter inputs voltage fluctuates.

0: No action

1: Action all the time

2: No action only during deceleration



Note

(1) When input voltage is higher than rated value, under normal situation, F04.11=1 shall be set. F02.11= 0 namely inverter is in deceleration stop, motor deceleration time short time running current will be greater. But the motor decrease speed placidly with small run current and long Dec time if choose AVR action all the time.

(2) When motor system vibration occurs due to AVR function, set F04.11= 0, namely AVR function is invalid.3.This function is valid in V/F control mode.

(3) This function is valid only in V/F mode.

F04.12	Random PWM adjustment depth	Range: 0~10	0
--------	-----------------------------	-------------	---

0: Random PWM is invalid.

1~10: The sharp electromagnetic noise of the motor can be improved by increasing this value. The larger the value, the smaller the sharp noise, but it may increase the harmonics of the motor current. This function is only valid for V/F control mode.

7 Detailed function specification

F04.13	Automatic energy saving operation	Range: 0, 1	0
--------	-----------------------------------	-------------	---

0: No action

1: Action

To reach better energy-saving effect, automatic energy-saving purpose can be obtained by checking load current.

When motor runs with no-load or light-load, energy-saving can be realized by checking load current, and properly adjusting input voltage. Auto energy-saving operation is mainly used in applications like stable load and revolving speed.



Note

- (1) This function is generally used in load like blower and water pump.
- (2) This function is valid only in V/F mode.

F04.14	Acceleration time 2 and 1 switchover frequency	Range: 0.00Hz~upper limit frequency	0.00Hz
F04.15	Deceleration time 2 and 1 switchover frequency	Range: 0.00Hz~upper limit frequency	0.00Hz

This function is used in the process of the inverter running, and we should adopted the acceleration time and deceleration for different applications.

During the acceleration process, if the frequency is lower than F04.14, we choose acceleration time 2, if the running frequency is bigger than F04.14, we choose acceleration time 1, during the deceleration process, if the running frequency is bigger than F04.15, then we choose deceleration time 1, if the running frequency is lower than F14.05, then we choose deceleration time 2.



Note

When using terminal to choose the deceleration time, F04.14, F04.15 function is invalid.

F04.16	Acceleration time 2	Range: 1~60000	200
F04.17	Deceleration time 2	Range: 1~60000	200
F04.18	Acceleration time 3	Range: 1~60000	200
F04.19	Deceleration time 3	Range: 1~60000	200
F04.20	Acceleration time 4	Range: 1~60000	200
F04.21	Deceleration time 4	Range: 1~60000	200
F04.22	Acceleration time 5	Range: 1~60000	200
F04.23	Deceleration time 5	Range: 1~60000	200
F04.24	Acceleration time 6	Range: 1~60000	200

F04.25	Deceleration time 6	Range: 1~60000	200
F04.26	Acceleration time 7	Range: 1~60000	200
F04.27	Deceleration time 7	Range: 1~60000	200
F04.28	Acceleration time 8	Range: 1~60000	200
F04.29	Deceleration time 8	Range: 1~60000	200
F04.30	Acceleration time 9	Range: 1~60000	200
F04.31	Deceleration time 9	Range: 1~60000	200
F04.32	Acceleration time 10	Range: 1~60000	200
F04.33	Deceleration time 10	Range: 1~60000	200
F04.34	Acceleration time 11	Range: 1~60000	200
F04.35	Deceleration time 11	Range: 1~60000	200
F04.36	Acceleration time 12	Range: 1~60000	200
F04.37	Deceleration time 12	Range: 1~60000	200
F04.38	Acceleration time 13	Range: 1~60000	200
F04.39	Deceleration time 13	Range: 1~60000	200
F04.40	Acceleration time 14	Range: 1~60000	200
F04.41	Deceleration time 14	Range: 1~60000	200
F04.42	Acceleration time 15	Range: 1~60000	200
F04.43	Deceleration time 15	Range: 1~60000	200

ENA100 defines 15 kinds of Acceleration/Deceleration time, select Acceleration/ deceleration time 1~15 during the inverter running by different combinations of control terminal. Please refer to the definitions of Acceleration/Deceleration time terminal function in F08.18~F08.25. Cooperating with simple PLC function can also realize each step of PLC adopting different acceleration/deceleration time to complete specific requirements.

The time unit of Acceleration/Deceleration time 2~15 above is the same as that of acceleration/deceleration time 1, all are decided by F01.19 parameter of acceleration/ deceleration time unit.



Acceleration/Deceleration time 1 is defined in F01.17 and F01.18.

Note

F04.44 ~ F04.47	Reserved		
-----------------------	----------	--	--

7.6 Communication control parameter group: F05

F05.00	Protocol selection	Range: 0~6	0
---------------	---------------------------	-------------------	----------

0: Modbus protocol .

1~4: Reserved.

5: Free protocol 1. Can realize the revision of all ENA100 function parameters

6: Free protocol 2. Can only realize the revision of part ENA100 function

parameters

F05.01	Baud rate configuration	Range: Units digit: 0~9 Tens digit: Reserved Hundreds digit: Reserved	005
---------------	--------------------------------	--	------------

F05.01 is for choosing communication baud rate when using different communication modules.

Units digit: Free protocol and Modbus Baud rate selection

0~3: Reserved

1: 600BPS

4: 4800BPS

5: 9600BPS

6: 19200BPS

7: 38400BPS

8: 57600BPS

9: 115200BPS

Tens digit: Reserved

Hundreds digit: Reserved

F05.02	Data format	Range: Units digit: 0~5 Tens digit: Reserved Hundreds digit: 0~2 Thousands digit: 0, 1	0000
---------------	--------------------	---	-------------

Units digit: Free protocol and Modbus protocol data format

0: 1-8-1 format, no parity, RTU. 1 for start bit, 8 for data bits, 1 for stop bit, no parity's RTU communication mode.

1: 1-8-1 format, even parity, RTU. 1 for start bit, 8 for data bits, 1 for stop bit, even parity's RTU communication mode.

2: 1-8-1 format, odd parity, RTU. 1 for start bit, 8 for data bits, 1 for stop bit, odd parity's RTU communication mode.

3: 1-7-1 format, no parity, ASCII. 1 for start bit, 7 data bits, 1 for stop bit, no parity's ASCII communication mode.

4: 1-7-1 format, even parity, ASCII. 1 for start bit, 7 data bits, 1 for stop bit,

even parity's ASCII communication mode.

5: 1-7-1 format, odd parity, ASCII. 1 for start bit, 7 data bits, 1 for stop bit, odd parity's ASCII communication mode.

Tens digit: Reserved

Hundreds digit: Modbus agreement or free protocol response selection

Under the condition that Modbus or protocol agreement and the hundreds of F05.02 is 1, when slave sends mainframe the demand of running, frequency revise and hide parameter inside, the slave is without response to increase the slave response speed. But when mainframe reads inverter parameter, status or revises inverter any parameter, the hundreds of F05.02 would not influence the slave response. The read-only instruction will respond only when the hundreds of F05.02 is 2.

Thousands digit: Communication Sets power down reserve setup. If this bit = 1, the communication address like 1D00H, 1D01H, 1D02H, 1D03H, 1D06H, 1D0AH, 1D0BH will reserve when power-off, otherwise not reserved when power-off.

F05.03	Local address	Range: 0~247	1
---------------	----------------------	---------------------	----------

During serial port communication, this function code is used to identify inverter's address.

Under free protocol communication, 00 is set and the inverter is master station, can be the Master-slave communication.

Under Modbus communication, 00 is broadcast address. When setting broadcast address, it can only receive and execute upper computer broadcast command, while cannot respond to upper computer.

F05.04	Communication overtime checkout time	Range:0.0~1000.0s	0.0s
---------------	---	--------------------------	-------------

When serial port communication fails and its continuous time exceed set value of this function code, the inverter judges it as communication failure.

The inverter would not detect serial port communication signal, namely this function ineffective when set value is 0.

F05.05	Communication error checkout time	Range: 0.0~1000.0s	0.0s
---------------	--	---------------------------	-------------

When serial port communication fails and its continuous time exceed set value of this function code, the inverter judges it as communication failure.

The inverter would not detect serial port communication signal, namely this function ineffective when set value is 0.

F05.06	Local response delay time	Range: 0~200ms (Modbus is valid)	2ms
---------------	----------------------------------	---	------------

7 Detailed function specification

Local response delay time represents the time within which the inverter serial port receives and executes command from upper device and then responds to upper device.

F05.07	Main & sub inverter communication frequency setting percentage	Range: 0~500%	100%
--------	--	---------------	------

After setting this parameter proportion when frequency sent from main inverter, as the input source of communication frequency of sub inverter, one inverter can control multiple devices with different proportional frequency.



Note

This parameter is valid only when inverter is master slave station and the frequency given channel is communication given.

F05.08	Communication virtual input terminal enabled	Range: 00~FFH	00H
--------	--	---------------	-----

Bit0: CX1 virtual input terminal enabled
 Bit1: CX2 virtual input terminal enabled
 Bit2: CX3 virtual input terminal enabled
 Bit3: CX4 virtual input terminal enabled
 Bit4: CX5 virtual input terminal enabled
 Bit5: CX6 virtual input terminal enabled
 Bit6: CX7 virtual input terminal enabled
 Bit7: CX8 virtual input terminal enabled

F05.09	Communication virtual input terminal joining node	Range: 0,1	0
--------	---	------------	---

0: Independent node. Communication virtual terminal function is only set in F05.10 ~ F05.17.

1: Terminal node. The communication virtual terminal function can only be set through F08.18~F08.25, and whether X1~X5 is valid or CX1~CX8 are valid, the function of this setting is executed. X1~X4 correspond to CX1~CX4, X5 corresponds to CX8, AI1 corresponds to CX5, AI2 corresponds to CX6.

F05.10	Communication virtual terminal CX1 function	Range: 0~90	0
F05.11	Communication virtual terminal CX2 function	Range: 0~90	0
F05.12	Communication virtual terminal CX3 function	Range: 0~90	0
F05.13	Communication virtual terminal CX4 function	Range: 0~90	0

F05.14	Communication virtual terminal CX5 function	Range: 0~90	0
F05.15	Communication virtual terminal CX6 function	Range: 0~90	0
F05.16	Communication virtual terminal CX7 function	Range: 0~90	0
F05.17	Communication virtual terminal CX8 function	Range: 0~90	0

Communication virtual terminal CX1 ~ CX8 function and terminal X1 ~ X5 function is different.



Note

The communication virtual terminal function is realized by setting the Modbus address and 1D009.

F05.18	Input mapping application parameter 1	Range: F00.00~F26.xx	25.00
F05.19	Input mapping application parameter 2	Range: F00.00~F26.xx	25.00
F05.20	Input mapping application parameter 3	Range: F00.00~F26.xx	25.00
F05.21	Input mapping application parameter 4	Range: F00.00~F26.xx	25.00
F05.22	Input mapping application parameter 5	Range: F00.00~F26.xx	25.00
F05.23	Input mapping application parameter 6	Range: F00.00~F26.xx	25.00
F05.24	Input mapping application parameter 7	Range: F00.00~F26.xx	25.00
F05.25	Input mapping application parameter 8	Range: F00.00~F26.xx	25.00
F05.26	Input mapping application parameter 9	Range: F00.00~F26.xx	25.00
F05.27	Input mapping application parameter 10	Range: F00.00~F26.xx	25.00

Input parameter address mapping.

This parameter is used for mapping waiting for input. Integral part corresponds with group no. of the parameter, while decimal part corresponds with intra-class reference (Parameter series no. within group parameter). For example: Setting F05.18=00.00 indicates that mapping F05.18=00.00 as input parameter 1.



Note

- (1) XX represents function code.
 (2) F25.xx represents not mapping.
 (3) By this way, some discontinuous parameters can be together to read the data, and using the input mapping application parameter to increase the communication efficiency. For example, if reading F00.00、F01.10、F02.02、F03.04、F03.12, you can map the above-mentioned parameters to F05.18, F05.19, F05.20, F05.21 and F05.22. Under RTU communication mode, only 1 continuous reading 5 groups of parameter commands (01 03 05 12 00 05 24 D1) can read 5 groups of parameter values, thus improving communication

F05.28 ~ F05.39	Reserved		
-----------------------	----------	--	--

7.7 Setting curve parameter group: F06

F06.00	Setting curve selection	Range: Units digit: 0~2 Tens digit: 0~2 Hundreds digit: 0~2 Thousands digit: 0~2	0000
--------	-------------------------	---	------

Units digit: AI1 curve selection

- 0: Curve 1.
- 1: Curve 2.
- 2: Curve 3.

Tens digit: AI2 curve selection

Same as units digit.

Hundreds digit: rapid pulse curve selection

Same as units digit.

Thousands digit: Pulse width setting curve selection

Same as units digit.

This function code units digit, tens digit, hundreds digit and thousands digit are used to select analog quantity input AI1, AI2, rapid pulse input and pulse width input signal setting curve. Curve 1 and 2 are 3 point curve, curve 3 is 4 point curve. User can select different curves for adjustment based on characteristic requirement of the input signal so as to realize specific input.

F06.01	Curve 1 min. setting	Range: 0.0% ~ Curve 1 Inflexion setting	0.0%
--------	----------------------	---	------

F06.02	Corresponding physical quantity of curve 1 min. setting	Range: 0.0 ~ 100.0%	0.0%
F06.03	Curve 1 inflexion setting	Range: curve 1 min. setting ~ Curve 1 Max. setting	50.0%
F06.04	Corresponding physical quantity of curve 1 inflexion setting	Range: 0.0 ~ 100.0%	50.0%
F06.05	Curve 1 Max. setting	Range: curve 1 inflexion setting ~100.0%	100.0%
F06.06	Corresponding physical quantity of curve 1 Max. setting	Range: 0.0 ~ 100.0%	100.0%
F06.07	Curve 2 min. setting	Range: 0.0% ~ Curve 2 inflexion setting	0.0%
F06.08	Corresponding physical quantity of curve 2 min. setting	Range: 0.0 ~ 100.0%	0.0%
F06.09	Curve 2 inflexion setting	Range: curve 2 min. setting ~ curve 2 Max. setting	50.0%
F06.10	Corresponding physical quantity of curve 2 inflexion setting	Range: 0.0 ~ 100.0%	50.0%
F06.11	Curve 2 Max. setting	Range: curve 2 inflexion setting ~ 100.0%	100.0%
F06.12	Corresponding physical quantity of curve 2 Max. setting	Range: 0.0 ~ 100.0%	100.0%
F06.13	Curve 3 min. setting	Range: 0.0% ~ curve 3 inflexion 1 setting	0.0%
F06.14	Corresponding physical quantity of curve 3 min. setting	Range: 0.0 ~ 100.0%	0.0%
F06.15	Curve 3 inflexion 1 setting	Range: curve 3 min. setting ~ curve 3 inflexion 2 setting	30.0%
F06.16	Corresponding physical quantity of curve 3 inflexion 1 setting	Range: 0.0 ~ 100.0%	30.0%
F06.17	Curve 3 inflexion 2	Range: curve 3 inflexion 1 setting ~	60.0%

7 Detailed function specification

	setting	curve 3 Max. setting	
F06.18	Corresponding physical quantity of curve 3 inflexion 2 setting	Range: 0.0 ~ 100.0%	60.0%
F06.19	Curve 3 Max. setting	Range: curve 3 inflexion 2 setting ~100.0%	100.0%
F06.20	Corresponding physical quantity of curve 3 Max. setting	Range: 0.0 ~ 100.0%	100.0%

Take curve 1 as an example:

Parameter F06.01 ~ F06.06 is used to set analog quantity input voltage and its representative set value relationship. When analog quantity input voltage is greater than the set “Max. input”(F06.05), analog quantity voltage is calculated based on “Max. input”; similarly, When analog input voltage is smaller than the set “min. input”(F06.01), Set based on “curve lower than min. input setting selection”(F06.21), calculated by min. input or 0.0%.



Note

- (1) For function and usage of curve 2, please refer to curve 1 instruction.
- (2) Curve 3 function is similar to curve 1 and curve 2, but curve 1 and 2 are three-point straight line, while curve 3 is four-point curve, which can realize more flexible corresponding relationship.
- (3) The output positive/negative polarity of curve 1, 2, 3 is decided by the features of input analog signal. Curve will not change output positive/negative polarity.
- (4) As frequency setting, 100.0% setting corresponding physical quantity is upper limit frequency F01.11.

F06.21	Curve lower than min. input corresponding selection	Range: Units digit: 0,1 Tens digit: 0,1 Hundreds digit: 0,1 Thousands digit: Reserved Ten thousands digit: Reserved	00111
--------	---	--	-------

Units digit: curve 1 setting

0: Corresponds to min. setting corresponding physical quantity.

1: 0.0% of the corresponding physical quantity.

Tens digit: curve 2 setting

Same as units digit.

Hundreds digit: curve 3 setting

Same as units digit.

Thousands digit: Reserved**Ten thousands digit: Reserved**

This parameter is used to set, when curve's corresponding analog quantity input voltage is smaller than the min. setting, how to decide corresponding setting analog quantity.

For example, F06.21 units=0, when analog quantity input is lower than F06.01, this curve output F06.02 corresponding physical quantity value. If F06.21 units=1, when analog quantity input is lower than F06.01, this curve output is 0.

Take 0 ~ 10V AI1 for setting frequency as an example: AI1 selects curve 1, setting frequency and AI1 relationship as shown in Fig. 7-11.

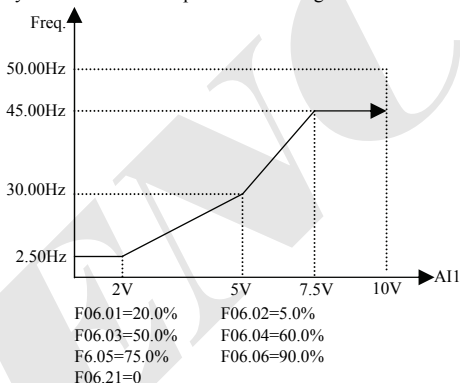

Fig. 7-11 AI1 selects curve 1 frequency setting

7.8 Analog quantity, Pulse input function parameter group: F07

F07.00	AI1 input filter time	Range: 0.000~9.999s	0.050s
F07.01	AI1 setting gain	Range: 0.000~9.999	1.006
F07.02	AI1 setting bias	Range: 0.0~100.0%	0.5%

AI1 input filter time, is used to set AI1 software filter time. When field analog quantity is easily interrupted, increase filter time to make the analog quantity check stable, but when filter time is greater, the response time of analog quantity check is slower. Please set according to the actual situation.

AI1 setting bias is indicated with Max. input (10V or 20mA) percentage, which is used to set up and down translation quantity of AI1 analog input. Take voltage input, bias positive as an example, the adjustment relationship of setting bias and gain adjustment before and after adjustment is as follows:

Analog input AI1 (After revise) = input gain (F07.01) × Analog input AI1 (Before revise) + setting bias (F07.02) × 10V

F07.03	AI2 input filter time	Range: 0.000~9.999s	0.050s
F07.04	AI2 setting gain	Range: 0.000~9.999	1.003
F07.05	AI2 setting bias	Range: 0.0~100.0%	0.1%

Parameter F07.03 ~ F7.05 is used to set analog quantity input AI2 filter time, gain and setting bias, For detail using method, please refer to analog quantity input AI1. Take voltage input, bias positive as an example, the adjustment relationship between gain adjustment and setting bias is as follows:

Analog input AI2 (after revise) = input gain (F07.04) × Analog input AI2 (before revise) + setting bias (F07.05) × 10V

Taking current input and bias positive as an example, the adjustment relationship between gain adjustment and setting bias is as follows:

Analog input AI2 (after revise) = input gain (F07.04) × Analog input AI2 (before revise) + setting bias (F07.05) × 20mA

F07.06	Analog setting bias polarity	Range: Units digit: 0,1 Tens digit: 0,1	01
--------	------------------------------	--	----

Units digit: AI1 setting bias polarity

0: Positive polarity.

1: Negative polarity.

Tens digit: AI2 setting bias polarity

0: Positive polarity.

1: Negative polarity.

Parameter F07.06 is used to set analog quantity AI1 and when AI2 counts the polarity of bias. Take voltage input as an example, when F07.06 units are set as 0:

Analog input AI1 (After revise) = input gain (F07.01) × Analog input AI1 (before revise) + Setting bias (F07.02) × 10V

When F7.06 units are set as 1:

Analog input AI1 (After revise) = input gain (F07.01) × Analog input AI1 (before revise) - Setting bias (F07.02) × 10V

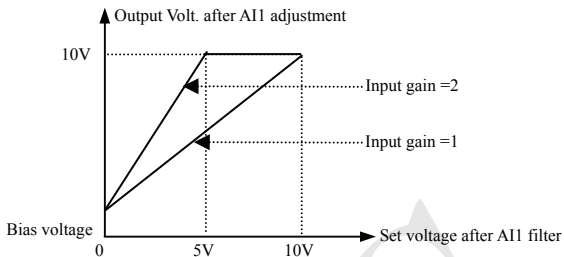

Fi.7-12 A11 adjustment

F07.07	Pulse input filter time	Range: 0.000~9.999s	0.000s
F07.08	Pulse input gain	Range: 0.000~9.999	1.000
F07.09	Pulse input Max. frequency	Range: 0.01~20.00KHz	10.00KHz

F07.07, F07.08 parameter defines filter time and gain when frequency channel selection terminal pulse is set. When setting filter time, Please be noted that the longer the filter time is, the slower the change rate of output frequency is. So set filter time properly according to the actual situation. Pulse width gain is for impulse quantity of current input impulse terminal.

F7.09 parameter defines frequency input range when frequency setting channel selection terminal pulse is set. When actual input frequency is greater than the set Max. frequency, deal with it according to Max. frequency. When the external input pulse is less than 2Hz, disposed as 0Hz.

F07.10	Pulse width input filter time	Range: 0.000~9.999s	0.000s
F07.11	Pulse width input gain	Range: 0.000~9.999	1.000
F07.12	Pulse width input logic setting	Range: 0,1	0
F07.13	Pulse width Max. input width	Range: 0.1~999.9ms	100.0ms

F07.10, F07.11 parameter defines filter time and gain when frequency channel selection terminal pulse width is set. When setting filter time, Please be noted that when the Max. pulse width set in F07.13 is smaller, the filter time is not suggested to be set too long, otherwise the response time of output frequency will be very slow. Pulse width gain is for impulse width duty cycle of current impulse width input terminal

0: Positive logic.

1: Negative logic.

F07.12 defines valid level of digital quantity input X5 channel input pulse when frequency channel selection terminal pulse width is set. The applications shall go

with double polarity working state of X input terminal.

F07.13 parameter defines the width range of input valid pulse when frequency setting channel selection terminal pulse width is set.

F07.14	Analog input disconnection detection threshold	Range: 0.0%~100.0%	10.0%
F07.15	Analog input disconnection detection time	Range: 0.0~500.0s	3.0s
F07.16	Analog disconnection protection option	Range: Units digit: 0,1,2 Tens digit: 0,1,2	10

Units digit: Disconnection detection channel choice

0: Invalid

1: AI1

2: AI2

Tens digit: Disconnection protection way

0: Stop according to stop mode

1: Fault, free stop

2: Continue operation

When channel (AI1 or AI2) selected by the units of F07.16 input a value less than the threshold defined by F07.14 and it is sustained exceed the time defined by F07.15, the program will generate a analog channel disconnection signal output, which can output signal for external by multifunctional output terminals (function 48) and the inverter will action according the command defined by tens of F07.16 : when the tens of F07.16 = 1, the inverter will be submitted to the E - 41 fault (analog channel disconnection protection; when tens of F07.16 = 0, inverter Stops according to stop mode.

By this function, AI1 and AI2 can be used to test position signal and motor temperature signal of the system and take corresponding protective measures. When don't need this function, set the units of F07.16 to 0.

F07.17 ~ F07.19	Reserved		
-----------------------	----------	--	--

7.9 On-off input function parameter group: F08

F08.00	Input terminal positive and negative logic setting	Range: 0000~FFFF	0000
---------------	---	-------------------------	-------------

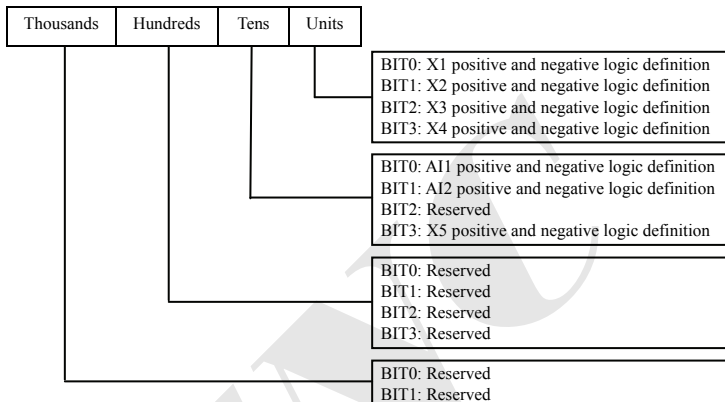

The setting of this parameter is finally converted to binary setting, relationship between binary setting and hexadecimal is as shown in table 7-2.

Table 7-2 Relationship between binary setting and bit displayed value

Binary setting				Hexadecimal (bit displayed value)
BI3	BIT2	BIT1	BIT0	
0	0	0	0	0
0	0	0	1	1
0	0	1	0	2
0	0	1	1	3
0	1	0	0	4
0	1	0	1	5
0	1	1	0	6
0	1	1	1	7
1	0	0	0	8
1	0	0	1	9
1	0	1	0	A
1	0	1	1	B
1	1	0	0	C

7 Detailed function specification

1	1	0	1	D
1	1	1	0	E
1	1	1	1	F

Bit refers to units, tens, hundreds or thousands displayed in operation panel.

F08.00 parameter defines valid logic state of Xi (Include AI1, AI2) input terminal:

Positive logic: Xi terminal and corresponding common port closed valid, opened invalid;

Negative logic: Xi terminal and corresponding common port closed invalid, opened valid;

When BIT selects 0, it indicates positive logic; 1 indicates negative logic. Proper setting of this parameter can realize correct logic input without changing terminal wiring.

F08.01	Input terminal filter time	Range: 0.000~1.000s	0.010s
---------------	-----------------------------------	----------------------------	---------------

F08.01 parameter sets filter time of input terminal check. When input terminal state is changed, the terminal state change is valid only when the set filter time is unchanged. Otherwise, it will remain the last state, thus effectively reduce malfunction caused by interruption. The group C or F17 monitor state is for the state of the disposed parameter. When demand terminal as the high speed function, low down the value of this parameter is needed in case losing the signal.

F08.02	X1 Input terminal closed time	Range: 0.00~99.99s	0.00s
F08.03	X1 Input terminal opened time	Range: 0.00~99.99s	0.00s
F08.04	X2 Input terminal closed time	Range: 0.00~99.99s	0.00s
F08.05	X2 Input terminal opened time	Range: 0.00~99.99s	0.00s
F08.06	X3 Input terminal closed time	Range: 0.00~99.99s	0.00s
F08.07	X3 Input terminal opened time	Range: 0.00~99.99s	0.00s
F08.08	X4 Input terminal closed time	Range: 0.00~99.99s	0.00s
F08.09	X4 Input terminal opened time	Range: 0.00~99.99s	0.00s
F08.10	AI1 Input terminal closed time	Range: 0.00~99.99s	0.00s
F08.11	AI1 Input terminal opened time	Range: 0.00~99.99s	0.00s
F08.12	AI2 Input terminal closed time	Range: 0.00~99.99s	0.00s
F08.13	AI2 Input terminal opened time	Range: 0.00~99.99s	0.00s
F08.14	Reserved	Range: 0.00~99.99s	0.00s
F08.15	Reserved	Range: 0.00~99.99s	0.00s
F08.16	X5 Input terminal closed time	Range: 0.00~99.99s	0.00s

F08.17	X5 Input terminal opened time	Range: 0.00~99.99s	0.00s
---------------	--------------------------------------	---------------------------	--------------

F08.02 ~ F08.17 parameter defines the corresponding delay time of Xi (Include AI1, AI2) input terminal from closed to opened or opened to closed so as to meet user's multiple requirements. This parameter does not affect the monitor value of input terminal state. You can revise the parameter to control the filtering when the interruption is strong.

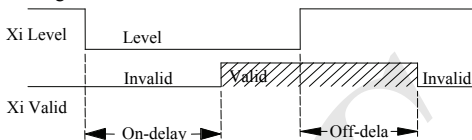

Fig. 7-13 Closed and opened delay

F08.18	Input terminal X1 function selection	Range: 0~90	1
F08.19	Input terminal X2 function selection	Range: 0~90	2
F08.20	Input terminal X3 function selection	Range: 0~90	0
F08.21	Input terminal X4 function selection	Range: 0~90	0
F08.22	Input terminal AI1 function selection	Range: 0~90	0
F08.23	Input terminal AI2 function selection	Range: 0~90	0
F08.24	Reserved		
F08.25	Input terminal X5 function selection	Range: 0~90	0

Multi-functional input terminal X1~X5, AI1, AI2 provides users with up to 96 selections, which can be selected based on actual applications. For details, please refer to parameter function Table 7-3.

Table 7-3 Multi-functional input selection function table

Content	Function	Content	Function
0	Leave control terminal unused	49	Command switchover to panel
1	Forward running FWD terminal	50	Command switchover to terminal
2	Reverse running REV terminal	51	Command switchover to communication
3	External forward jogging control	52	Running command Channel selection terminal 1
4	External reverse jogging control	53	Running command Channel selection terminal 2
5	Multi-step speed control terminal 1	54	Forward prohibited command (Stop according to the stop mode, invalid for jogging command)

7 Detailed function specification

6	Multi-step speed control terminal 2	55	Reverse prohibited command (Stop according to the stop mode, invalid for jogging command)
7	Multi-step speed control terminal 3	56	Swinging frequency input
8	Multi-step speed control terminal 4	57	Resetting state of swinging frequency
9	Acceleration/Deceleration time selection terminal 1	58	Interior counter reset end
10	Acceleration/Deceleration time selection terminal 2	59	Interior counter input end
11	Acceleration/deceleration time selection terminal 3	60	Internal timer resetting
12	Acceleration/deceleration time selection terminal 4	61	Internal timer triggering
13	Main and auxiliary frequency operational rule selection terminal 1	62	Length count input
14	Main and auxiliary frequency operational rule selection terminal 2	63	Length reset
15	Main and auxiliary frequency operational rule selection terminal 3	64	Reset this operation time
16	Frequency ascending command (UP)	65	Speed/torque control switching
17	Frequency descending command (DOWN)	66	Reserved
18	Frequency ascending/descending frequency resetting	67	Reserved
19	Multi-step closed loop terminal 1	68	Reserved
20	Multi-step closed loop terminal 2	69	Reserved
21	Multi-step closed loop terminal 3	70	Water shortage signal input (closed means water shortage)
22	External equipment failure input	71	Water signal input (closed means there is water)
23	External interruption input	72	Reserved
24	External resetting input	73	Reserved
25	Free stop input	74	Reserved
26	External stop instruction—Stop according to the stop mode	75	Reserved
27	stop DC braking input command DB	76	Reserved
28	inverter running prohibited—Stop	77	Reserved

	according to the stop mode		
29	Acceleration/deceleration prohibited command	78	Reserved
30	Three-wire running control	79	Reserved
31	Process PID invalid	80	Reserved
32	Process PID stop	81	Reserved
33	Process PID integral holding	82	Reserved
34	Process PID integral resetting	83	Reserved
35	Process PID function negation (Closed loop adjustment feature negation)	84	Reserved
36	Simple PLC invalid	85	Reserved
37	Simple PLC halted	86	Reserved
38	Simple PLC stop state resetting	87	Reserved
39	Main frequency switchover to digit (keypad)	88	Reserved
40	Main frequency switchover to AI1	89	Reserved
41	Main frequency switchover to AI2	90	Reserved
42	Reserved	91	Pulse frequency input (X5 VALID)
43	Reserved	92	Pulse width PWM INPUT (X5 VALID)
44	Main frequency setting channel selection terminal 1	93	Reserved
45	Main frequency setting channel selection terminal 2	94	Reserved
46	Main frequency setting channel selection terminal 3	95	Reserved
47	Main frequency setting channel selection terminal 4	96	Reserved
48	Auxiliary frequency reset	-	-

Function introduction in Table 7-3 is as shown below:

1, 2: External command terminal. When running command channel is terminal running command, control inverter's forward and reverse by external terminal.

3, 4: External jogging command terminal. Set as any running command channel setting running command, control inverter's jogging forward and jogging reverse by external terminal.

5-8: Multi-step running terminal. By setting these functions' terminal

ON/OFF combination, up to 15 multi-step running frequencies can be set. The acceleration and deceleration time of each stage of multi-speed corresponds to F01.17 and F01.18 by default. When F01.16 thousands digit=0, the acceleration and deceleration time correspond to acceleration and deceleration 1-15 (ie F01.17, F01.18, F04.16~F04.43). The motor running direction corresponding to each stage of multi-speed is determined by the tens digit of F10.01~F10.15.

Table 7-4 Multi-step running selection table

K ₄	K ₃	K ₂	K ₁	Acceleration and deceleration (F01.16 thousand digit=0)	Acceleration and deceleration (F01.16 thousand digit=1)	Frequency setting
OFF	OFF	OFF	OFF	F01.17、F01.18	F01.17、F01.18	Other operating frequency
OFF	OFF	OFF	ON	F01.17、F01.18	F01.17、F01.18	F10.31
OFF	OFF	ON	OFF	F04.16、F04.17	F04.16、F04.17	F10.32
OFF	OFF	ON	ON	F04.18、F04.19	F04.18、F04.19	F10.33
OFF	ON	OFF	OFF	F04.20、F04.21	F04.20、F04.21	F10.34
OFF	ON	OFF	ON	F04.22、F04.23	F04.22、F04.23	F10.35
OFF	ON	ON	OFF	F04.24、F04.25	F04.24、F04.25	F10.36
OFF	ON	ON	ON	F04.26、F04.27	F04.26、F04.27	F10.37
ON	OFF	OFF	OFF	F04.28、F04.29	F04.28、F04.29	F10.38
ON	OFF	OFF	ON	F04.30、F04.31	F04.30、F04.31	F10.39
ON	OFF	ON	OFF	F04.32、F04.33	F04.32、F04.33	F10.40
ON	OFF	ON	ON	F04.34、F04.35	F04.34、F04.35	F10.41
ON	ON	OFF	OFF	F04.36、F04.37	F04.36、F04.37	F10.42
ON	ON	OFF	ON	F04.38、F04.39	F04.38、F04.39	F10.43
ON	ON	ON	OFF	F04.40、F04.41	F04.40、F04.41	F10.44
ON	ON	ON	ON	F04.42、F04.43	F04.42、F04.43	F10.45

When using multi-step speed to run and simple PLC to run, use multi-step speed frequency (F10.31~F10.45) above, take multi-step speed running as an example:

Define control terminal X1, X2, X3, X4:

When F08.18=5, F08.19=6, F08.20=7, F08.21=8, X1, X2, X3, X4 are used to define multi-step speed running, as shown in Fig. 7-14.

In Fig. 7-14. Take the example of terminal running command channel, the ten's place of F10.01~F10.15 are both 2, and X5 is set as forward running terminal, A11 is reverse running terminal, for the running control of forward direction and reverse direction.

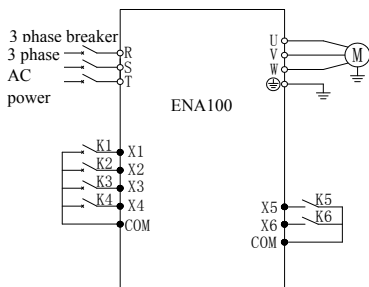

Fig.7-14 Multi-step speed running wiring

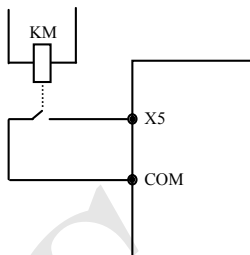

Fig.7-15 Peripheral equipment fault Normally Open

9~12:Acceleration/deceleration time terminal selection. By ON/OFF of Acceleration/Deceleration time terminal, acceleration/deceleration time 1 ~ 15 can be selected. For details, see Table 7-5:

Table 7-5 Acceleration/deceleration time terminal selection

Acceleration/ deceleration time selection terminal 4	Acceleration/ deceleration time selection terminal 3	Acceleration/ deceleration time selection terminal 2	Acceleration/ deceleration time selection terminal 1	Acceleration/deceleration time selection
OFF	OFF	OFF	ON	Acceleration/deceleration time 1
OFF	OFF	ON	OFF	Acceleration/deceleration time 2
OFF	OFF	ON	ON	Acceleration/deceleration time 3
OFF	ON	OFF	OFF	Acceleration/deceleration time 4
OFF	ON	OFF	ON	Acceleration/deceleration time 5
OFF	ON	ON	OFF	Acceleration/deceleration time 6
OFF	ON	ON	ON	Acceleration/deceleration time 7
ON	OFF	OFF	OFF	Acceleration/deceleration time 8
ON	OFF	OFF	ON	Acceleration/deceleration time 9
ON	OFF	ON	OFF	Acceleration/deceleration time 10
ON	OFF	ON	ON	Acceleration/deceleration time 11
ON	ON	OFF	OFF	Acceleration/deceleration time 12
ON	ON	OFF	ON	Acceleration/deceleration time 13
ON	ON	ON	OFF	Acceleration/deceleration time 14

				14
ON	ON	ON	ON	Acceleration/deceleration time 15

13 ~ 15: Main and auxiliary frequency operational rule selection terminal. By ON/OFF of frequency setting channel selection terminal 13, 14, and 15, 7 kinds of main and auxiliary frequency operational rules defined in F01.06 parameter can be realized. Switchover between main and auxiliary operational rule terminal is prior to function code F01.06 setting. For details, please see table 7-6:

Table 7-6 Selection table of terminal main and auxiliary frequency operational rule

Main and auxiliary operational rule selection terminal 3	Main and auxiliary operational rule selection terminal 2	Main and auxiliary operational rule selection terminal 1	Main and auxiliary operational rule selection
OFF	OFF	OFF	Decided by F01.06
OFF	OFF	ON	Synthesized frequency is sub-frequency
OFF	ON	OFF	Operation rule: addition
OFF	ON	ON	Operation rule: subtraction
ON	OFF	OFF	Operation rule: multiplication
ON	OFF	ON	Synthesized frequency is Max. value
ON	ON	OFF	Synthesized frequency is min. value
ON	ON	ON	Synthesized frequency is nonzero value

16, 17: Frequency ascending command UP/descending command DOWN. Realize frequency ascending or descending by control terminal, substitute operation keypad for remote control. Normal running F01.00 or F01.03 set as 3 is valid. Ascending/descending rate is set in F18.06 and F18.07.

18: Frequency ascending/descending frequency resetting.

When frequency setting is set as terminal UP/DOWN, this terminal can eliminate the set frequency value by terminal UP/DOWN.

19 ~ 21: Multi-step closed loop setting terminal. By ON/OFF of multi-step closed loop setting terminal, Table 7-7 Multi-step closed loop setting selection can be realized.

Table 7-7 Multi-step closed loop setting selection table

Multi-step closed loop setting selection terminal 3	Multi-step closed loop setting selection terminal 2	Multi-step closed loop setting selection terminal 1	Multi-step closed loop setting selection

OFF	OFF	OFF	Closed loop setting decided by F11.01
OFF	OFF	ON	Multi-step closed loop setting 1
OFF	ON	OFF	Multi-step closed loop setting 2
OFF	ON	ON	Multi-step closed loop setting 3
ON	OFF	OFF	Multi-step closed loop setting 4
ON	OFF	ON	Multi-step closed loop setting 5
ON	ON	OFF	Multi-step closed loop setting 6
ON	ON	ON	Multi-step closed loop setting 7

22: External equipment failure jump-in. with this terminal, peripheral equipment fault signal can be input, which is convenient for inverter to perform fault monitoring for peripheral equipment, as shown in Fig.7-15.

23: External interruption input. When the inverter is running, after receiving external interruption signal, it blocks output, and runs with zero frequency. Once external interruption signal is released, and inverter running command is still valid, inverter auto revolving speed tracking starts, the inverter restarts.

24: External resetting input. When fault alarm occurs to the inverter, you can reset fault by this terminal. Its function and operation keypad  key function are in accordance.

25: Free stop input. The purpose of this function and free stop set in F02.11 is the same, but here it uses control terminal to realize, which is convenient for remote control.

26: External stop instruction. This command is effective for all running command channel, when this function terminal is effective, the inverter stops running according to mode set by F02.11.

27: Stop DC braking input command DB. Implement DC braking to the motor during stop by control terminal so as to realize emergency stop and accurate position of the motor. During deceleration stop, if this function terminal closed, when frequency is lower than the brake starting frequency F02.14, it will brake according to brake current defined in F02.16. It will not stop until terminal is opened.

28: Inverter running prohibited. The running inverter stops freely when this terminal is effective, and forbidden to start in waiting status. It is mainly applied to occasion needing safe linkage.

29: Acceleration/deceleration prohibited command. When this function is valid, keep the motor away from any external signal (except stop command), maintain current revolving speed running.



Note

This function is invalid in normal deceleration stop process.

30: Three-wire running control. Refer to F08.26 operating mode (Three-wire operating mode) function introduction.

31: Process PID invalid. Realize flexible switchover in low-level running mode under closed-loop running status.



Note

(1) Switchover between closed-loop and low level running mode can be available only when the inverter runs in closed-loop mode ($F11.00=1$ or $F12.00>0$).

(2) When switching to low-level running mode, start-stop control, direction and acceleration/deceleration time comply with relevant setting of running mode.

32: Process PID stop. Invalid when PID stops, when inverter maintains current output frequency, PID regulation of frequency source is no more performed.

33: Process PID integral holding. PID integral impact maintains, and will not regulate according to the output quantity.

34: Process PID integral resetting. When the terminal is valid, PID integral regulation function halts, but PID proportional control and differential control function are still valid.

35: Process PID function negation. When the terminal is valid, direction of PID effect and setting direction of F11.13 is opposite.

36: simple PLC invalid. Realize flexible switchover in low-level running mode under PLC running status.



Note

(1) Switchover between PLC and low level running mode can be available only when the inverter runs in PLC mode (F10.00 unit's digit is not 0).

(2) When switching to low-level running mode, start-stop control, direction and acceleration/deceleration time comply with relevant setting of running mode.

37: Simple PLC halted. It is to control the stop of running PLC, when the terminal is valid, the inverter runs at zero frequency, PLC running does not time; after invalid implementation, auto revolving speed tracking starts and keep on running PLC.

38: Simple PLC stop state resetting. Under stop status of PLC running mode, will clear PLC run step, runtime, run frequency etc. recorded when PLC running stops if this terminal is effective, please see F10 group function description.

39: Main frequency switchover to digital setting (keypad). The main frequency provision channel is switched to keypad digital provision when this terminal is valid (setting frequency by keypad up and down key).

40: Main frequency switchover to AI1. The main frequency provision channel is switched to analog quantity AI1 provision when this terminal is valid

41: Main frequency switchover to AI2. The main frequency provision channel is switched to analog quantity AI2 provision when this terminal is valid

42, 43: Reserved

44 ~ 47: Main frequency setting channel selection terminal. By ON/OFF of selection terminal 1 ~ 4, Free selection of main frequency setting channel can be realized by terminal. The priority of main frequency setting channel selection terminal (Terminal function 44 ~ 47) is higher than the main frequency switchover to (Terminal function 39, 40, 41). For details, see table 7-8.

Table 7-8 Main frequency setting channel selection terminal

Channel selection terminal 4	Channel selection terminal 3	Channel selection terminal 2	Channel selection terminal 1	Main frequency setting channel selection terminal
OFF	OFF	OFF	ON	Operation keypad digital setting
OFF	OFF	ON	OFF	AI1 analog setting
OFF	OFF	ON	ON	AI2 analog setting
OFF	ON	OFF	OFF	Terminal UP/DOWN setting
OFF	ON	OFF	ON	Communication setting
OFF	ON	ON	OFF	Reserved
OFF	ON	ON	ON	Reserved
ON	OFF	OFF	OFF	Rapid pulse setting (X5)
ON	OFF	OFF	ON	Pulse width given (X5)
ON	OFF	ON	OFF	Terminal encoder setting (X1, X2)
ON	OFF	ON	ON	Reserved
ON	ON	OFF	OFF	Reserved
ON	ON	OFF	ON	Reserved
ON	ON	ON	OFF	Reserved

48: Auxiliary frequency reset. Only valid for digit auxiliary frequency, when this function terminal is valid, reset auxiliary frequency setting quantity, setting frequency is completely decided by main frequency setting channel.

49: Command switchover to panel. When current command source is reset by terminal or communication, switchover between current command source and keypad command setting can be realized by this terminal.

50: Command switchover to terminal. When current command source is reset by keypad or communication, switchover between current command source and terminal command setting can be realized by this terminal.

51: Command switchover to communication. When current command source is reset by keypad or terminal, switchover between current command source and communication command setting can be realized by this terminal.

52, 53: Running command Channel selection terminal. For details, please refer to Table 7-9.

Table 7-9 Running command channel logic mode

Running command channel selection terminal 2	Running command channel selection terminal 1	Running command channel
OFF	OFF	Invalid
OFF	ON	Operation keypad running command channel
ON	OFF	Terminal running command channel
ON	ON	Communication running command channel

54: Forward prohibited command. Enable this terminal during the forward running process, and the inverter stops according to the stop mode. First enable this terminal, and then forward running enters zero frequency running status. Jogging running is not affected by this.

55: Reverse prohibited command. Function and “Forward prohibited command” are opposite.

56: Swinging frequency input. When the starting mode of swinging frequency is manual input, this terminal is valid, and swinging frequency function is valid. See F13 group function parameter instruction. When swinging frequency is set as manual input, this terminal is invalid, run with preset frequency of swinging frequency.

57: Resetting state of swinging frequency. When selecting swinging frequency function, no matter auto or manual input mode, closing this terminal will clear state information of swinging frequency memorized in the inverter. When opening this terminal, swinging frequency restarts. For details, please see F13 group function.

58: Interior counter reset end. Reset inverter built-in counter, and go with counter triggering signal input. For details, please see parameter F08.27, F08.28.

59: Interior counter input end. Interior counter’s counting pulse input port, pulse max. frequency: 50.0KHz.

60: Interior timer reset end. Reset inverter built-in timer, goes with timer triggering-end signal input.

61: Interior timer triggering end. See parameter F08.29 function.

62: Length count input. Length counting input terminal, see fixed length function of F13 group parameter.

63: Length reset. When the terminal is valid, reset internal length value, see F13 fixed length function of parameter group.

64: Reset this operation time. When the terminal is valid, the running counting time of this inverter is reset, see timing running defined in F18 group.

65: Speed/torque control switching. The function of this terminal is only

effective under the mode of Speed Mode, this terminal can realize the dynamic switching between torque Mode and Speed Mode.

66~69: Reserved.

70: Water shortage signal input. Closed means water shortage. For details, please refer to F17 water shortage protection function parameter description.

71: Water signal input. Closed means there is water. For details, refer to the description of the function parameter of the water shortage protection in group F17.

72~90: Reserved

91: Pulse frequency input (X5 valid). Only valid for multi-functional input terminal X5, this function terminal accepts pulse signal as frequency setting, relationship between the input signal pulse frequency and setting frequency is as shown in F06 and F07 group parameter.

92: Pulse width PWM input (X5 valid). Only valid for multi-functional input terminal X5, this function terminal accepts PWM signal, check pulse width as frequency setting, relationship between input PWM Pulse width and setting frequency is as shown in F06 and F07 group parameter.

93~96: Reserved

F08.26	FWD/REV operating mode selection	Range: 0~4	0
--------	----------------------------------	------------	---

This parameter defines five different modes by controlling external terminal inverter running.

0: Two-wire control mode 1

K2	K1	Operating command
0	0	Stop
1	0	REV
0	1	FWD
1	1	Stop

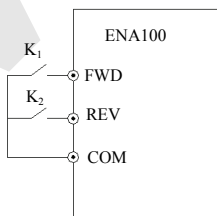

Fig. 7-16 Two-wire operating mode 1

1: Two-wire control mode 2

K2	K1	Operating command
0	0	Stop
1	0	Stop
0	1	FWD
1	1	REV

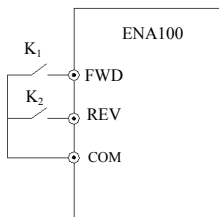

Fig. 7-17 Two-wire operating mode 2

2: Two-wire control mode 3 (Monopulse control mode)

Monopulse control is triggered-type control. After triggering SB1 once, it forwards runs. Retriggering SB1 once, it stops. Triggering SB1 once, it reversely runs. Retriggering SB2 once, it stops. If it is forward running, the inverter stops when triggering SB2 once. Retriggering SB1 once, it stops. If it is reverse running, the inverter stops when triggering SB1 once.

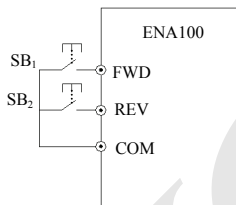

Fig. 7-18 Two-wire control mode 3

3: Three-wire control mode 1

Defines are as follows:

SB1: Stop button

SB2: Forward button

SB3: Reverse button

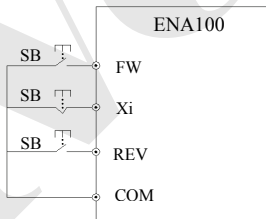

Fig. 7-19 Three-wire operating mode 1

Xi is Multi-functional Input terminal of X1~X5, AI1, AI2, at this moment, define its corresponding terminal function as “Three-wire running control” function of No.30.

4: Three-wire control mode 2

SB1: Stop button

SB2: Run button

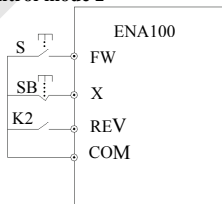

K2	Running direction selection
0	Forward
1	Reverse

Fig. 7-20 Three-wire operating mode 2

Xi is Multi-functional Input terminal of X1~X5、AI1、AI2, At this moment, define its corresponding terminal function as “Three-wire running control” function of No.30.

F08.27	Set internal count value to setting	Range: 0~65535	0
F08.28	Specify internal count to setting	Range: 0~65535	0

F08.27 and F08.28 are to additionally define functions of 30 and 31 in 7-10.

When Xi (Counting trigger signal input function terminal, include AI1, AI2) output pulse reaches F08.27 defined value, Y1 (Y1 is set as internal count value final value to) outputs one indicating signal, as shown in Fig. 7-21, When Xi inputs the eighth pulse, Y1 outputs one indicating signal. At this moment, F8.27=8.

When Xi (Counting trigger signal input function terminal, include AI1, AI2) output pulse reaches F08.28 defined value, Y2 (Y2 is set as internal counter specified value to) outputs one indicating signal, until set count value arrives.

As shown in Fig. 7-21, when Xi inputs the fifth pulse, Y2 starts outputting one indicating signal. Until set count value 8 arrives, F08.28=5. When specified count value is greater than set count value, specified count value Invalid.

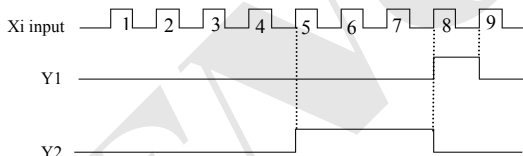

Fig. 7-21 Set count value setting and specified count value setting

F08.29	Internal timer timing setting	Range: 0.1~6000.0s	60.0s
---------------	--------------------------------------	---------------------------	--------------

This parameter sets timing time of inverter internal timer, timer is triggered by external triggering terminal (Xi terminal (Include AI1, AI2) function no. is 61), the timer starts timing upon receiving external triggering signal. After reaching timing time, Yi terminal outputs a breadth of 0.5s valid pulse signal. When internal timer clearing terminal is valid (Xi terminal (Include AI1, AI2) function is set as 60), internal timer is reset.

F08.30	Terminal pulse encoder frequency rate	Range: 0.01~10.00Hz	1.00Hz
---------------	--	----------------------------	---------------

This parameter defines main frequency regulation speed during terminal pulse encoder setting frequency (F01.00=9). Main frequency terminal encoder pulse input can only choose channel X1 and X2 combination; auxiliary frequency terminal encoder pulse input can only choose channel X3 and X4 combination, and the rate of the auxiliary frequency encoder frequency is the fixed rate.



Note

When 9 is selected in F01.00 and F01.03, X1~X4 can only be used as encoder frequency setting. Other terminal functions defined by F08.18~F08.21 are invalid.

F08.31	Special function selection	Range: Units digit:0,1 Tens digit :0,1	00
--------	----------------------------	---	----

Units digit: jogging priority level selection

0: The highest priority level

1: The lowest priority level

Tens digit: Keypad adjustment of display setting (Under speed control mode)

0: Display setting frequency

1: Display setting rotation speed

F08.32 ~ F08.35	Reserved		
-----------------------	----------	--	--

7.10 Switch output function parameter group: F09

F09.00	The output setting of open circuit collector output terminal Y1	Range: 0~60	0
F09.01	The output setting of open circuit collector output terminal Y2	Range: 0~60	0
F09.02	Reserved		
F09.03	Reserved		
F09.04	RLY1 output setting	Range: 0~60	22

Functions of the above parameters are used to select Y1, Y2 and relay output terminals. Table 7-10 shows the functions of the above 4 terminals. One function can be selected repeatedly.

Open-collector (Yi) and high-speed pulse (DO) output share terminal Y2. Y2 terminal as the high-speed pulse function to be modified F00.22 thousands place to 1

Table7-10 Output terminals function selection diagram

Setting	Function	Setting	Function
0	No output	31	Set count value reached
1	Frequency inverter running (RUN)	32	Designated count value reached
2	Frequency inverter Forward running	33	Shutdown time arrival of the running
3	Frequency inverter Reverse running	34	Time arrival of the running
4	Frequency inverter DC brake	35	Setup running time arrived
5	Frequency inverter Ready for	36	Setup power-on time arrived

	operation (RDY)		
6	Shutdown command indicator	37	1st pump variable frequency
7	Zero current state	38	1st pump frequency
8	Over current state	39	Reserved
9	Current 1 arrived	40	Reserved
10	Current 2 arrived	41	Communication given
11	Frequency inverter Zero-frequency output	42	Torque control speed limiting
12	Frequency arriving signal (FAR)	43	Torque arriving output
13	Frequency level detection signal 1 FDT1	44	Reserved
14	Frequency level detection signal 2 (FDT2)	45	The brake logic 1 (Brake would be applied during forward and reverse switching.)
15	Output frequency arriving upper limit (FHL)	46	The brake logic 2 (Brake wouldn't be applied during forward and reverse switching.)
16	Output frequency arriving lower limit(FLL)	47	Frequency inverter running 1 (Not jog running)
17	Frequency 1 arrived	48	Analog input disconnection signal output
18	Frequency 2 arrived	49	X1 terminal closed valid
19	Frequency inverter overload pre-alarm signal (OL)	50	X2 terminal closed valid
20	Frequency inverter Low voltage lock-up signal (LU)	51	Water shortage fault output
21	External stopping command(EXT)	52	Lifting special brake control
22	Frequency inverter fault	53	Reserved
23	Frequency inverter warning	54	Reserved
24	Simple PLC operation running	55	Reserved
25	Completion of simple PLC operation	56	Reserved
26	Simple PLC cycle-running completed	57	Reserved
27	Simple PLC suspended	58	Reserved
28	Upper and lower limit of Wobble	59	Reserved
29	Setup length arrived	60	Reserved
30	Internal counter final value arrived	-	-

The instructions of the function output terminals listed in table 7-10 are as below:

0: The terminal function is idle.

1: Frequency inverter is running (RUN). The Drive is in the running state,

output the indicator signal (No output during sleep).

2: Frequency inverter is forward running. The Drive is in the forward running state, output the indicator signal.

3: Frequency inverter is reversed running. The Drive is in reversed running state, output the indicator signal.

4: Frequency inverter is DC braking. The Drive is in DC braking state, output the indicator signal.

5: Frequency inverter is ready to run. This signal being valid means that the Drive bus voltage is normal, the Drive is running and forbidding the terminal is invalid, it can accept a start command.

6: Shutdown command indicator. When the shutdown command is valid, output the indicator signal. (Not jog running)

7: Zero current is arrived. When detected the output meet the zero current state, output the indicator signal. Please refer to the instruction of F09.12 and F09.13 parameters for details.

8: Over current is arrived. When the output current meet the over current detection conditions, output the indicator signal. Please refer to the instruction of F09.14 and F09.15 parameters for details.

9: Current 1 arrived. When the output current reaches the detection conditions to meet the current 1, output the indicator signal. Please refer to the instruction of F09.16 and F09.17 parameters for details.

10: Current 2 arrived. When the output current reaches the detection conditions to meet the current 2, output the indicator signal. Please refer to the instruction of F09.18 and F09.19 parameters for details.

11: Frequency inverter Zero frequency output. Please refer to the function instruction of F09.10 and F09.11.

12: Frequency arriving signal (FAR). Please refer to the function instruction of F09.05.

13: Frequency level detection signal 1(FTD1). Please refer to the function instruction of F09.06, F09.07.

14: Frequency level detection signal 2(FTD2). Please refer to the function instruction of F09.08, F09.09.

15: Output frequency reaches upper limit (FHL). When the running frequency reaches upper limit, the output is indicator signal.

16: Output frequency reaches lower limit (FLL). When the running frequency reaches lower limit, the output is indicator signal.

17: Frequency 1 arriving output. Please refer to the function instruction of F09.20, F09.21.

18: Frequency 2 arriving output. Please refer to the function instruction of F09.22, F09.23.

19: Frequency inverter overload pre-alarm signal (OL). Frequency inverter output current exceeds F19.06 overload pre-alarm detection levels, and time is greater than F19.07 overload pre-alarm delay time, output the indicator signal.

20: Frequency inverter Low voltage lock-up signal (LU). When the frequency inverter is running, the DC bus voltage below the limit level, output indication signal.

21: External fault shutdown (EXT). When the frequency inverter appears external fault trip alarm (E-18), output indication signal.

22: Frequency inverter fault. When the frequency inverter detects fault, the output is indication signal.

23: Frequency inverter warning. When the frequency inverter detects alarm, the output is indication signal.

24: Simple PLC during operating. The simple PLC is enabled, and enter into operation state, output indication signal

25: Simple PLC stage operation completed. When the simple PLC stage operation is completed, output indication signal (Single pulse signal, the width is 500ms).

26: Simple PLC ends after running a cycle. After the completion of a cycle of simple PLC, output indication signal (single pulse signal, the width is 500ms)

27: Simple PLC pause. When the simple PLC is running into the pause state, output is indication signal.

28: Wobble upper and lower limit. If the frequency fluctuation range calculated by center frequency exceeds the upper limit F01.11 or belows lower limit F01.12 after selecting the wobble function, it will output indication signal, as shown in Fig.7-22.

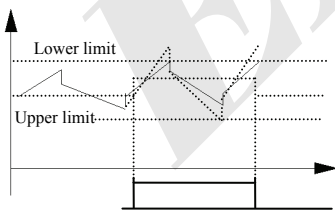

Y1: Wobble upper and lower

Fig.7-22 Wobble amplitude limit diagram

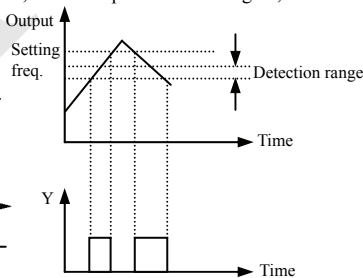

Fig.7-22 Freq. arrival signal output diagram

29: Setup length arrived. When detected the actual length exceeds a set value F13.08, output indication signal.

30: Internal counter final value arrived. Please refer to the function instruction of F08.27.

31: Internal counter specified value arrived. Please refer to the function instruction of F08.28.

32: Internal counter timing meter arrival. Please refer to the function instruction of F08.29.

33: Shutdown time arrival of the running. Frequency inverter runs longer than the setting time of F18.12, output indication signal.

34: Time arrival of the running. Frequency inverter runs longer than the setting time of F18.13, output indication signal.

35: Setup time arrived. Accumulated running time of the frequency inverter reaches the set accumulated running time (F18.10), output indication signal.

36: Setup power-on time arrived. Accumulated power on time of the frequency inverter reaches the set accumulated running time (F18.09), the output indication signal.

37: The first pump runs with frequency conversion.

38: The second pump runs with frequency conversion.

39: Reserved.

40: Reserved.

When using Y1,Y2 achieve two pumps constant pressure water supply (F12.00=5), Y1,Y2 functions are arranged in order of 37,38. Under constant pressure water supply mode, the four parameters must all set to this value, the terminal functions can be achieved

41: Communication given. In this moment the output of Yi is controlled by communication, Please refer to the related communication protocol for details.

42: Torque control speed limiting. Under the mode of torque control, when the actual output frequency is greater than or equal to the value of limiting frequency, this output terminal is effective. The value of speed limiting is defined by parameter F14.24 to F14.27.

43: Torque arriving output. Under the torque control, when the motor torque reaches to the torque command which is after the acceleration and deceleration, and continue for the time defined by F09.48, then output active level.

44: Reserved.

45: The brake logic 1. When the output frequency is greater than the value (F09.10 + F09.11), output valid signal (Loose brake signal) , when the output frequency is less than the value defined by F09.10 ,output brake signal .when output no current, downtime, under voltage, that will output brake signals.

46: The brake logic 2. Deceleration stop and the output frequency is less than F09.10, output brake signal. Run the command starts, when the output frequency is greater than the value (F09.10 + F09.11), output valid signal (Loose brake signal). If

output no current, downtime, under voltage, that will output brake signals. What difference with the function 45 is that can't produce brake signal in the forward /reverse switching process (that is, the switching process of a controlled object from rising to falling or falling to rising), so as to prolong the life of the brake system.

47: Frequency inverter running 1. When the inverter is in the running state and not jog operation state, output the valid signal.

48: Analog input disconnection signal output. When the disconnection signal defined by F07.14 to F07.16 is valid, a valid pulse of 0.5 second will be output, and then the system will add pump or reduce pump.

49: X1 Terminal closed valid

50: X2 Terminal closed valid

51: Water shortage fault output.

52: Improve the special brake function. Cooperate with lifting special function for brake control, please refer to F24 group description for details.

53~60: Reserved.

F09.05	Detection amplitude of frequency arrival (FAR)	Range: 0.00~50.00Hz	5.00Hz
--------	--	---------------------	--------

This parameter is added in the definition of Table 7-10 on the 12th functions. As shown in Fig.7-23, when the inverter output frequency in the setting frequency of positive and negative detection width, output indication signal.

F09.06	FDT1 (Frequency level)level	Range: 0.00Hz~upper limit frequency	10.00Hz
F09.07	FDT1 lag	Range: 0.00~50.00Hz	1.00Hz
F09.08	FDT2 (Frequency level)level	Range: 0.00Hz~upper limit frequency	10.00Hz
F09.09	FDT2 lag	Range: 0.00~50.00Hz	1.00Hz

F09.06, F09.07 is in the definition of Table 7-10 on the 13th Functions, F09.08, F09.08 is in the definition of Table 7-10 on the 14th functions, take an example of 13th functions: When the output frequency exceeds a certain setting frequency (FDT1 level), output indicator Signal, until the output frequency drops below the certain frequency FDT1 frequency level (FDT1 level -FDT1 lag). As shown in Figure 7-24.

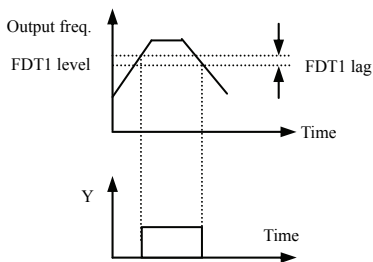

Fig.7-24 Freq. level detection diagram

F09.10	Zero-frequency signal detection value	Range: 0.00Hz~upper limit frequency	0.40Hz
F09.11	Zero-frequency backlash	Range: 0.00Hz~upper limit frequency	0.10Hz

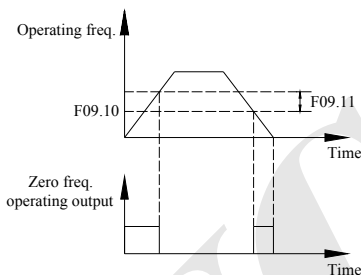

Fig.7-25 Zero-frequency signal detection

Parameter F09.10, F09.11 defines the zero frequency output control function. When the output frequency is within the zero-frequency signal detection range, if Yi output function selects 11, then the output of Yi is indication signal.

F09.12	Zero current detection amplitude	Range: 0.0~50.0%	0.0%
F09.13	Zero current detection time	Range: 0.00~60.00s	0.1s

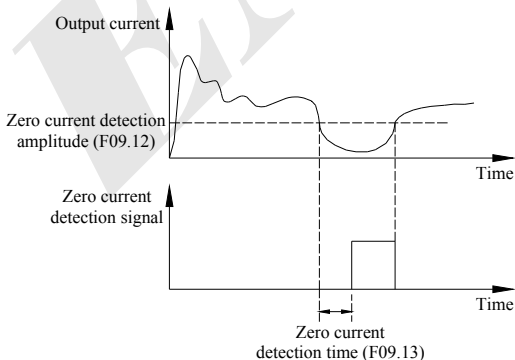

Fig.7-26 Zero current detection diagram

When the output current of the inverter is less than or equal to zero current detection level, and lasts longer than the zero current detection time, then the output of frequency inverter multifunction Yi is indication signal. Fig.7-26 is the schematic of zero current detection.

F09.14	Over-current detection value	Range: 0.0~250.0%	160.0%
F09.15	Over-current detection time	Range: 0.00~60.00s	0.00s

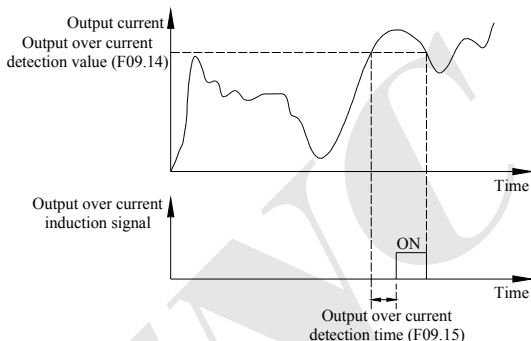

Fig.7-27 Output over-current detection diagram

When the output current of the inverter is greater than the over-current detection points, and lasted longer than the over-current detection time, frequency inverter multifunction Yi output indication signal, Fig.7-27 is the schematic of output over-current detection.

F09.16	Current 1 arriving the detection value	Range: 0.0~250.0%	100.0%
F09.17	Current 1 width	Range: 0.0~100.0%	0.0%
F09.18	Current 2 arriving the detection value	Range: 0.0~250.0%	100.0%
F09.19	Current 2 width	Range: 0.0~100.0%	0.0%

When the output current of frequency inverter is within the positive and negative detection width of setting current arrival, then the output of frequency inverter multifunction Yi is indication signal.

ENA100 provides two current arrival and detection width parameters, table 7-28 is the function schematic diagram.

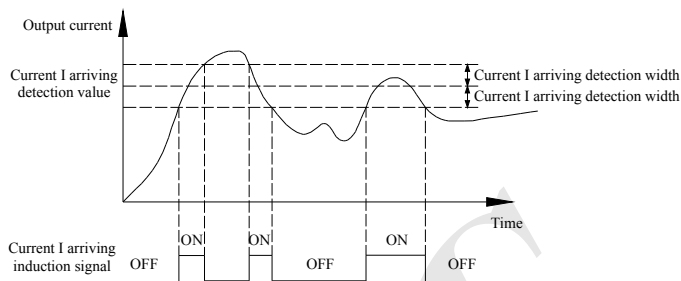

Fig.7-28 Current arriving detection diagram

F09.20	Frequency 1 arriving detection value	Range:0.00Hz~upper limit frequency	50.00Hz
F09.21	Frequency 1 arriving detection width	Range:0.00Hz~upper limit frequency	0.00Hz
F09.22	Frequency 2 arriving detection value	Range:0.00Hz~upper limit frequency	50.00Hz
F09.23	Frequency 2 arriving detection width	Range:0.00Hz~upper limit frequency	0.00Hz

When the output frequency of frequency inverter reaches detecting value of the positive and negative detecting width range, then the output of multifunctional Y_i is indication signal.

ENA100 provides two sets of frequency arrival detecting parameters, which have set frequency value and frequency detecting width respectively. Table 7-29 is the diagram of this function.

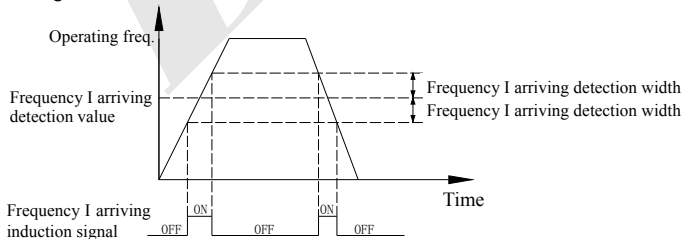

Fig.7-29 Frequency arriving detection diagram

F09.24	Positive and negative logic setting of output terminal	Range: 0000~FFFF	0000
---------------	---	-------------------------	-------------

This parameter defines the output logic of the standard output terminal Yi, relay RLY and expand output Yi, RLY1.

0: Positive logic, output terminal and the common terminal close to the valid state, disconnect invalid state

1: Reverse logic, output terminal and the common terminal close to the invalid state, disconnect valid state

Thousands	Hundreds	The tens	The units
BIT0:Y1 positive and negative logic definition BIT1:Y2 positive and negative logic definition BIT2: Reserved BIT3: Reserved			
BIT0: RLY1 positive and negative logic definition BIT1: Reserved BIT2: Reserved BIT3: Reserved			
BIT0: Reserved BIT1: Reserved BIT2: Reserved BIT3: Reserved			
BIT0~BIT3: Reserved			

F09.25	Y1 output closed delay time	Range: 0.000~50.000s	0.000s
F09.26	Y1 output disconnected delay time	Range: 0.000~50.000s	0.000s
F09.27	Y2 output closed delay time	Range: 0.000~50.000s	0.000s
F09.28	Y2 output disconnected delay time	Range: 0.000~50.000s	0.000s
F09.29 ~ F09.32	Reserved		
F09.33	Relay output closed delay time	Range: 0.000~50.000s	0.000s
F09.34	Relay output disconnected delay time	Range: 0.000~50.000s	0.000s

Parameter F09.25 ~ F09.34 defines the corresponding delay time from connect or disconnect to frequency level of the multifunction output terminals. Table 7-30 is

the schematic of multi-function output terminal operation.

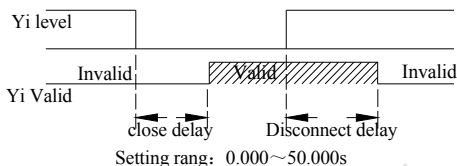

Fig.7-30 Multifunction output terminal action diagram

F09.35	Analog output (AO1) selecting	Range: 0~25	0
F09.36	Reserved		
F09.37	DO function selecting(Reuse with Y2)	Range: 0~25	0

0: Output frequency before slip compensation (0.00Hz~ upper limit frequency)

1: Output frequency after slip compensation (0.00Hz~ upper limit frequency)

2: Setup frequency (0.00Hz~ upper limit frequency)

3: Master setup frequency (0.00Hz~ upper limit frequency)

4: Auxiliary setup frequency (0.00Hz~ upper limit frequency)

5: Current output 1(0~2×rated current of frequency inverter)

6: Current output 2(0~3×rated current of frequency inverter)

7: Output voltage (0~1.2×rated voltage of load motor)

8: Bus voltage (0~1.5×Rated bus voltage)

9: Motor speed (0~3 ×rated speed)

10: PID given (0.00~10.00V)

11: PID feedback (0.00~10.00V)

12: AI1 (0.00~10.00V).

13: AI2 (0.00~10.00V or 0~20mA).

14: Communication given (AO output is controlled by communication, please refer to the related communication protocol for details.)

15: Motor rotate speed (0.00Hz~upper limit frequency)

16: Current given torque (0~2 times of rated torque)

17: Current output torque (0~2 times of rated torque)

18: Current torque current (0~2 times of rated motor current)

19: Current flux current (0~1 times of rated motor flux current)

20~25: Reserved



Note

- (1) Terminal AO1 and AO2 are optional output terminal of 0~10V or 0~20mA which can satisfy the variety needs of customer.
- (2) By disposing F00.21 analog output, output of terminal AO1 and AO2 can be 0~10V or 0~20mA to satisfy the variety needs of customer.
- (3) The unit's place of F00.22 is set to 1 when DO output pulse signal.
- (4) Rated flux current=current value of F15.11 parameter. Rated torque current=sqrt (rated motor current×rated motor Current-rated flux current×rated flux current)

F09.38	Reserved		
F09.39	Analog output (AO1) filter time	Range: 0.0~20.0s	0.0s
F09.40	Analog output (AO1) gain	Range: 0.00~2.00	1.00
F09.41	Analog output (AO1) bias	Range: 0.0~100.0%	0.0%

Parameter F09.39 defines the filter time of AO1 output, its reasonable setting can improve stability of analog output. But a higher setting will influence the rate of change, which can not reflect the instantaneous value of corresponding physical quantity.

If users want to change the display range or error correction table headers, you can achieve it by adjusting the output gain and bias of AO1.

When AO1 output voltage, the adjustment is as follows:

Analog output AO1 (After revise) =output gain (F09.40) ×analog output AO1 (before revise) +output bias (F09.41) ×10V

When AO1 output current, the adjustment is as follows:

Analog output AO1 (After revise) =output gain (F09.40) × analog output AO1 (before revise)+output bias(F09.41)×20mA



Note

This function code will influence analog output during modify processes.

F09.42 ~ F09.44	Reserved		
-----------------------	----------	--	--

F09.45	DO filter time	Range: 0.0~20.0s	0.0s
F09.46	DO output gain	Range: 0.00~2.00	1.00

7 Detailed function specification

F09.47	DO maximum pulse output frequency	Range: 0.1~20.0KHz	10.0KHz
--------	-----------------------------------	--------------------	---------

Please refer to the function introduce of parameters F09.39~F09.41.

Maximum pulse output frequency of terminal DO corresponds to maximum select value of F09.47. For example, F09.31=0, terminal DO's function is: output frequency before slip compensation, which means Maximum pulse output frequency corresponds to upper frequency.

Note: When the output frequency of DO port is less than 1.5Hz, disposed as 0Hz.

F09.48	Torque reaches to the detection time	Range: 0.02~200.00s	1.00s
--------	--------------------------------------	---------------------	-------

F09.49	Application macro selection	Range: 0~4	0
--------	-----------------------------	------------	---

0: Ordinary model

1: Air compressor application

2: Extruder application

3: Water pump application

4: Fan application

Please refer to Appendix D for application macro usage details.

F09.50 ~ F09.55	Reserved		
-----------------------	----------	--	--

7.11 Simple PLC/Multi-speed function parameters Group:F10

F10.00	Simple PLC operate setting	Range: Unit digit: 0~3 Tens digit: 0~2 Hundreds digit: 0,1 Thousands digit: 0,1	0000
--------	----------------------------	--	------

Use units, tens, hundreds and thousands to set the PLC operation mode, restart mode after interruption, operation time unit and power-down storage mode, as follows:

Unit digit: simple PLC operation mode.

0: No action. PLC operation mode is disabled.

1: Stop after single cycle. as show in Fig.7-31, the drive stops automatically after one cycle of operation and will not start only when receiving RUN command again.

2: Maintain final value after one cycle, as show in Fig.7-32, the drive will keep running with the final value and the direction after complete one cycle operation, the drive won't stop according to the set stop mode until the stop command is available.

3: Continuous operation, as show in Fig.7-33, the drive will start next cycle of operation automatically after completing one cycle of operation until receiving STOP command then stop according the set stop mode.

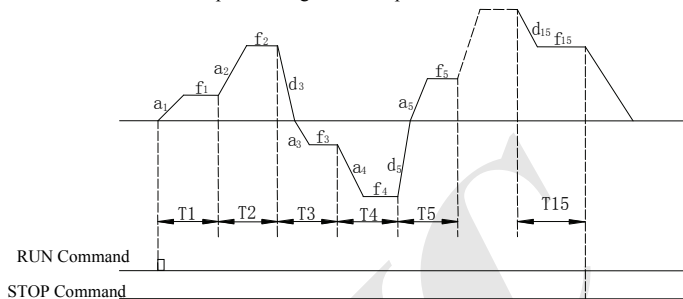

Fig.7-31 PLC stop operating after one cycle mode

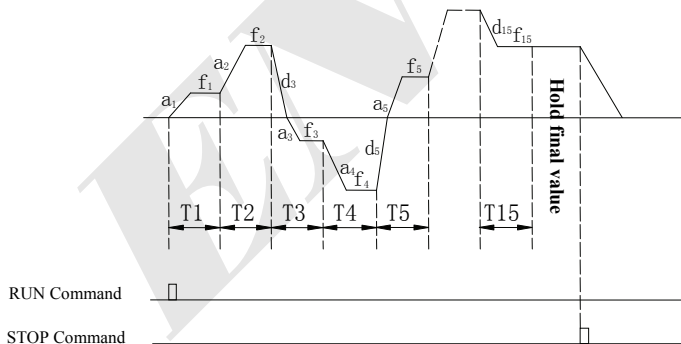

Fig.7-32 PLC holds the final value after one cycle mode

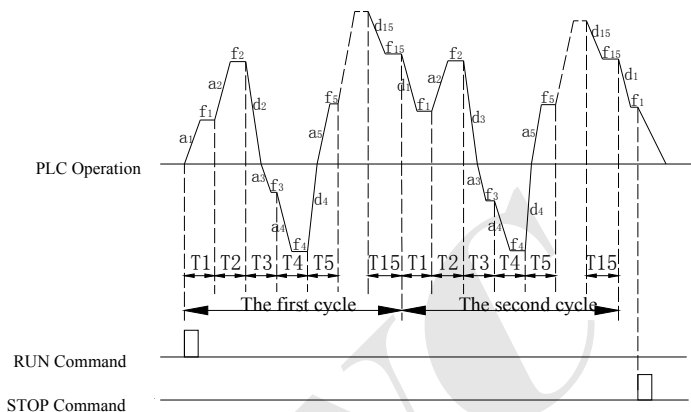

Fig7-33 PLC continuous operation mode

a1~a15: The Acc time of different steps

d1~d15: The Dec time of different steps

f1~f15: The frequency of different steps

There are 15 steps can set in Fig.7-31, 7-32, 7-33.

Tens digit: Restart mode after interruption.

0: Restart from the first step.

If the drive stops during PLC operation due to receiving STOP commands, fault alarm or power failure, it will run from the first step after restarting.

1: Restart from the interruption step;

If the drive stops during PLC operation due to receiving STOP command or fault alarm, the drive will record the operating time of the current step and will continue from the step where the drive stops after restart at the frequency defined for this step with the remained time, as show in Fig.7-34.If the drive stops due to power off, it will not record the state and from the first step operate when restart.

2: Restart from the interrupted Frequency

If the drive stops during PLC operation due to receiving STOP command or fault alarm, the drive will record the operating time and the current frequency of the interrupt step, it will operating with the record time and record frequency when restart, as show in Fig7-35.

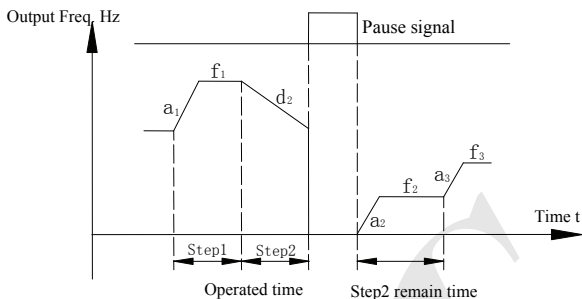

a_1 : Acc time of the 1st step

a_2 : Acc time of the 2nd step

a_3 : Acc time of the 3rd step

d_2 : Dec time of the 1st step

f_1 : Frequency of the 1st step

f_2 : Frequency of the 2nd step

f_3 : Frequency of the 3rd step

Fig.7-34 Simple PLC restart mode 1

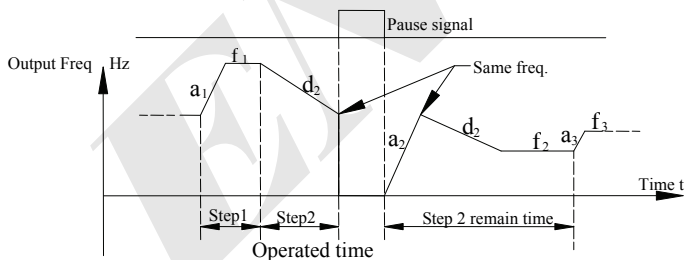

a_1 : Acc time of the 1st step

a_2 : Acc time of the 2nd step

a_3 : Acc time of the 3rd step

d_2 : Dec time of the 1st step

f_1 : Frequency of the 1st step

f_2 : Frequency of the 2nd step

f_3 : Frequency of the 3rd step

Fig.7-35 PLC Restart mode 2

Hundreds digit: PLC unit of running time.

0: Seconds;

1: Minutes;

The unit is effective for the running time of different steps only, during the operation of PLC, the unit of Acc time and Dec time is defined by parameter F01.19.

**Note**

(1) The step is ineffective if the time of this step of PLC operation is set as 0 thereafter operate the next step.

(2) Control the PLC process a pause, ineffective, operate via terminal, for details please refer to parameters in F8 Group that relative with terminal function.

Thousands digit: The storage mode when power off.

0: No storage. No record the running state when power off, it will restart from the first step when power on again.

1: Storage. Records the running status which include the step, running frequency and running time when power off, it restart with the mode that set in hundreds digit after power on again.

**Note**

No matter power-off storage in stop status or running status, you should set thousands digit as 1 thereafter set tens digit as 1 or 2, otherwise power-off storage function is ineffective.

F10.01	Step 1 setting	Range: 000H~E22H	020
F10.02	Step 2 setting	Range: 000H~E22H	020
F10.03	Step 3 setting	Range: 000H~E22H	020
F10.04	Step 4 setting	Range: 000H~E22H	020
F10.05	Step 5 setting	Range: 000H~E22H	020
F10.06	Step 6 setting	Range: 000H~E22H	020
F10.07	Step 7 setting	Range: 000H~E22H	020
F10.08	Step 8 setting	Range: 000H~E22H	020
F10.09	Step 9 setting	Range: 000H~E22H	020
F10.10	Step 10 setting	Range: 000H~E22H	020
F10.11	Step 11 setting	Range: 000H~E22H	020
F10.12	Step 12 setting	Range: 000H~E22H	020
F10.13	Step 13 setting	Range: 000H~E22H	020
F10.14	Step 14 setting	Range: 000H~E22H	020
F10.15	Step 15 setting	Range: 000H~E22H	020

F10.01~F10.15 are respectively defined as the frequency setting, direction and acceleration/deceleration time of PLC operation with the units digit, tens digit and hundreds digit, as follows:

Unit digit: Frequency setting

0: Select multi-frequency i. i=1~15, please refer to F10.31~F10.45 for definitions of multi-frequency.

1: The frequency is determined by the combination of the main frequency and the auxiliary frequency.

2: Reserved.

Tens digit: The selection of running direction for PLC and multi-speed.

0: Forward.

1: Reversed.

2: Determined by operating commands (FWD, REV)

Hundreds digit: Acc/Dec time choose

0: Acc/Dec time 1

1: Acc/Dec time 2

2: Acc/Dec time 3

3: Acc/Dec time 4

4: Acc/Dec time 5

5: Acc/Dec time 6

6: Acc/Dec time 7

7: Acc/Dec time 8

8: Acc/Dec time 9

9: Acc/Dec time 10

A: Acc/Dec time 11

B: Acc/Dec time 12

C: Acc/Dec time 13

D: Acc/Dec time 14

E: Acc/Dec time 15

Accelerate time1~15 defined by F01.17, F01.18, F04.16~F04.43. The running direction of PLC and multi-speed is determined by the ten's place of F10.01~F10.15.

F10.16	Step 1 running time	Range: 0~6000.0	10.0
F10.17	Step 2 running time	Range: 0~6000.0	10.0
F10.18	Step 3 running time	Range: 0~6000.0	10.0
F10.19	Step 4 running time	Range: 0~6000.0	10.0
F10.20	Step 5 running time	Range: 0~6000.0	10.0
F10.21	Step 6 running time	Range: 0~6000.0	10.0
F10.22	Step 7 running time	Range: 0~6000.0	10.0

7 Detailed function specification

F10.23	Step 8 running time	Range: 0~6000.0	10.0
F10.24	Step 9 running time	Range: 0~6000.0	10.0
F10.25	Step 10 running time	Range: 0~6000.0	10.0
F10.26	Step 11 running time	Range: 0~6000.0	10.0
F10.27	Step 12 running time	Range: 0~6000.0	10.0
F10.28	Step 13 running time	Range: 0~6000.0	10.0
F10.29	Step 14 running time	Range: 0~6000.0	10.0
F10.30	Step 15 running time	Range: 0~6000.0	10.0

Parameters F10.16~F10.30 defined Running time of each PLC Step from Step 1 to Step 15.



Each step running time include Acc time and Dec time.

Note

F10.31	Multi-Frequency 1	Range:0.00Hz~upper limit Freq.	5.00Hz
F10.32	Multi-Frequency 2	Range:0.00Hz~upper limit Freq.	10.00Hz
F10.33	Multi-Frequency 3	Range:0.00Hz~upper limit Freq.	20.00Hz
F10.34	Multi-Frequency 4	Range:0.00Hz~upper limit Freq.	30.00Hz
F10.35	Multi-Frequency 5	Range:0.00Hz~upper limit Freq.	40.00Hz
F10.36	Multi-Frequency 6	Range:0.00Hz~upper limit Freq.	45.00Hz
F10.37	Multi-Frequency 7	Range:0.00Hz~upper limit Freq.	50.00Hz
F10.38	Multi-Frequency 8	Range:0.00Hz~upper limit Freq.	5.00Hz
F10.39	Multi-Frequency 9	Range:0.00Hz~upper limit Freq.	10.00Hz
F10.40	Multi-Frequency 10	Range:0.00Hz~upper limit Freq.	20.00Hz
F10.41	Multi-Frequency 11	Range:0.00Hz~upper limit Freq.	30.00Hz
F10.42	Multi-Frequency 12	Range:0.00Hz~upper limit Freq.	40.00Hz
F10.43	Multi-Frequency 13	Range:0.00Hz~upper limit Freq.	45.00Hz
F10.44	Multi-Frequency 14	Range:0.00Hz~upper limit Freq.	50.00Hz
F10.45	Multi-Frequency 15	Range:0.00Hz~upper limit Freq.	50.00Hz

Frequency will be used in Multi-speed operation mode and Simple PLC operation mode. More details please refer to the Multi-speed terminal operation function in Parameters Group F08 and Simple PLC operation function in Parameters Group F10.

7.12 Closed-Loop PID operation Parameters Group:F11

Analog feedback control system:

Pressure reference is input through the terminal AI1, and water pressure sensor send a 0~20mA to the terminal AI2 of inverter as a feedback signal, all of them make up of analog closed-loop control system via build-in PID adjuster ,as shown in Fig.7-36.

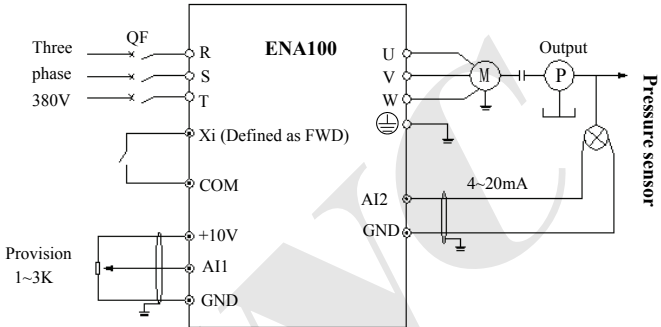

Fig.7-36 Build-in PID adjuster control system diagram



Note

Setting the value of F11.01 can choose the channel of pressure reference.

Operating principle of built-in PID function of ENA100 is shown in Fig.7-37 as below:

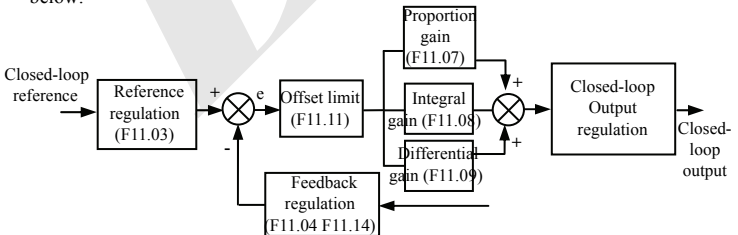

Fig.7-37 PID block control principle diagram

In above diagram, the definition of closed-loop reference, feedback error limit

and PI parameters are similar with the general PID adjuster, the relationship between reference and expected feedback is shown in Fig.7-38. The reference and feedback are converted and based on 10.00V.

In Fig.7-37, the real values of closed-loop reference and feedback can be regulated in Group F06 and F07, so that can reach a good performance.

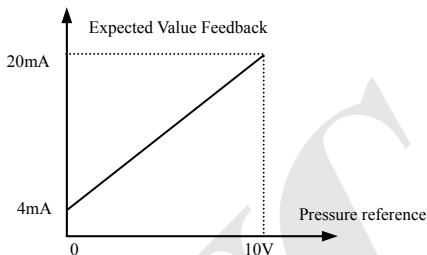

Fig.7-38 Reference and expected feedback value

After the system control mode is confirmed, follow the procedures below to set the closed-loop parameters:

- (1) Determine the closed-loop reference and feedback channel (F11.01, F11.02).
- (2) The relationship between the closed-loop reference and feedback should be defined for closed-loop control (The Group F6).
- (3) Set up the closed-loop frequency presetting function (F11.19, F11.20).
- (4) Adjust the proportion gain, integral gain, differential gain, sampling cycle and error limit (F11.07~F11.11).

F11.00	Closed-loop control function	Range: 0,1	0
---------------	-------------------------------------	-------------------	----------

0: PID closed-loop function disabled

1: PID closed-loop function enabled

F11.01	Reference channel choose	Range: 0~7	0
---------------	---------------------------------	-------------------	----------

0: Digital provision

1: AI1 analog provision

2: AI2 analog provision

3, 4: Reserved

5: Pulse provision

6: Communication provision (Communication address: 1D00). Please refer to the chapter of Modbus communication.

7: Reserved



Note

Except the above provision channels, Multi-Closed-loop provision is available. Connecting different terminal to choose different provision value which with a highest priority.

F11.02	Feedback channel selection	Range: 0~9	0
--------	----------------------------	------------	---

0: AI1 analog input

1: AI2 analog input

2, 3: Reserved

4: AI1+AI2

5: AI1-AI2

6: Min {AI1, AI2}

7: Max {AI1, AI2}

8: Pulse input

9: Communication feedback (Address is 1DOC, 4000 stands for 10.00V)

F11.03	Provision channel filtering time	Range: 0.00~50.00s	0.00s
F11.04	Feedback channel filtering time	Range: 0.00~50.00s	0.00s
F11.05	PID output filtering time	Range: 0.00~50.00s	0.00s

The external reference signal and feedback signal usually carry some noise. those noise signal can be filtered by setting the time constant of filter in F11.03 and F11.04. The bigger the time constant is, the better the immunity capability, but with a slow response. The shorter the time constant is, the faster the response, but the immunity capability became weak.





PID output filter time is the filter time for closed-loop output (frequency or torque). The longer the output filter time, the slower the output response.

F11.06	Provision digital setting	Range: 0.00~10.00V	1.00V
--------	---------------------------	--------------------	-------

This function can realize digital setting of reference via keypad.



Note

When the PID function is enabled, Setting F18.14 as 1 can adjust pressure reference by press  , otherwise the   keys are invalid for adjusting reference in monitoring mode.

F11.07	Proportion Gain Kp	Range: 0.00~100.00	0.50
F11.08	Integral Gain Ki	Range: 0.01~10.00	0.25
F11.09	Differential Gain Kd	Range: 0.00~10.00	0.00
F11.10	Sampling cycle T	Range: 0.01~1.00s	0.10s

The bigger of the proportion gain of Kp, the faster the response, but oscillation

may easily occur.

If only proportion gain K_p is used in regulation, the offset cannot be eliminated completely. To eliminate the offset, please use the integral gain K_i to form a PI control system. The bigger K_i is, the faster the response, but oscillation may easily occur if K_i is big enough.

The sampling cycle T refers to the sampling cycle of feedback value. The PI D regulator calculates once in each sampling cycle. The bigger the sampling cycle is, the slower the response.

F11.11	Deviation limit	Range: 0.0~20.0%	2.0%
---------------	------------------------	-------------------------	-------------

If defines the max. Deviation of the output from the reference, as shown in Fig.7-39, the PID adjuster stops operation when the feedback value within this range. Setting this parameter correctly will improve the moderation of the accuracy and stability of the system.

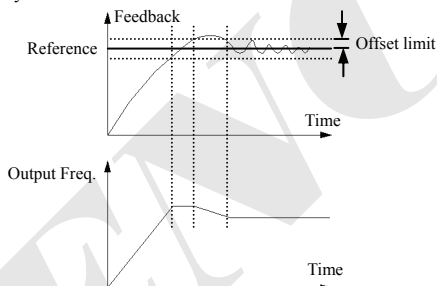

Fig.7-39 Offset limit



Note

Offset limit is the percentage refer to the value of reference.

F11.12	PID differential amplitude limit	Range: 0.00~100.00%	0.10%
---------------	---	----------------------------	--------------

In the PID regulator, the effect of differential is too sensitive too easy to cause system oscillation, therefore limit the effect of differential PID in a smaller range, F11.12 the parameter that used to set the output range of PID differential.

F11.13	Closed-loop regulation characteristic	Range: 0,1	0
---------------	--	-------------------	----------

0: Positive effect. When the provision increases, select while requiring speed of motor increase.

1: Negative effect. When the provision increases, select while requiring speed of motor decrease.

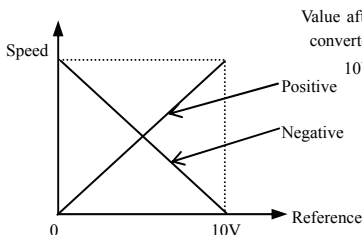

Fig.7-40 Closed-loop characteristic

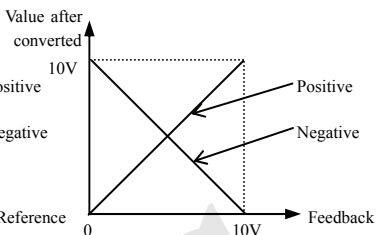

Fig.7-41 Feedback characteristic

F11.14	Feedback channel positive-negative characteristic	Range: 0,1	0
--------	--	------------	---

0: Positive characteristic. The relationship between reference and feedback is positive

1: Negative characteristic. The relationship between reference and feedback is negative

This parameter is used to change the feedback characteristic of the feedback signal. After input into inverter through the feedback channel, the feedback pressure will compare with the reference after regulated by the positive and negative characteristic regulation, as shown in Fig.7-41.

F11.15	PID regulation upper limit frequency	Range: 0.00Hz~upper limit Frequency	50.00Hz
F11.16	PID regulation lower limit frequency	Range: 0.00Hz~upper limit Frequency	0.00Hz

User can set up the parameters F11.15 and F11.16 to define the output lower limit and upper limit frequency of the PID regulator.

F11.17	Integral regulation selection	Range: 0,1	0
--------	-------------------------------	------------	---

0: Stop integral regulating when the comparison value of the reference and feedback reaches the range of threshold for integral separation

1: Keep integral regulating even though the comparison value of the reference and feedback reach the range of threshold integral separation.

Adjusting this parameter can avoid integral saturation and improve the response of the system.

F11.18	PID threshold of the integral separation	Range: 0.0~100.0%	100.0%
--------	---	-------------------	--------

PID integral separated function: there is no integral regulating just proportion regulating during closed-loop control when the comparison value that between reference and feedback is bigger than this threshold. When the comparison is smaller

than this threshold, the integral regulating will be active, and can adjust the response speed of system by adjusting this parameter.

F11.19	Preset Closed-loop frequency	Range: 0.00Hz~upper limit frequency	0.00Hz
F11.20	Holding time of preset Closed-loop frequency	Range: 0.0~6000.0s	0.0s

This function can make the closed-loop adjuster into the stable status quickly.

When the closed-loop function start, the output frequency will ramp up to the preset closed-loop frequency (F11.19) within the Acc time, and keep running the time that set in F11.20 then start the closed-loop operation as shown is Fig.7-42

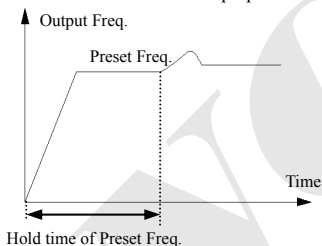

Fig.7-42 Preset closed-loop operating



Note

If the closed-loop preset frequency function is not needed, set the preset frequency and hold time to 0.

F11.21	Closed-loop output reversion selection	Range: 0~2	2
--------	--	------------	---

0: The inverter will run with the low limit frequency when the closed-loop output value is negative

1: The inverter will reverse running when the value of the closed-loop output is negative (Be opposite of the initial direction)

2: Determined by running demand. The motor running direction is determined by demand direction.



Note

The comparison value can be display in the PID monitor parameters, it's positive when the reference bigger than the feedback value, and negative when reference smaller than feedback value.

F11.22	Closed-loop output reversion frequency upper limit	Range: 0.00Hz~upper limit Frequency	50.00Hz
--------	--	-------------------------------------	---------

The PID regulator is a kind of bipolar adjustment. By setting F11.21 and F11.22, can choose whether the inverter reverse run in some degree frequency or not.

F11.23	Multiple closed-loop provision 1	Range: 0.00~10.00V	0.00V
F11.24	Multiple closed-loop provision 2	Range: 0.00~10.00V	0.00V
F11.25	Multiple closed-loop provision 3	Range: 0.00~10.00V	0.00V
F11.26	Multiple closed-loop provision 4	Range: 0.00~10.00V	0.00V
F11.27	Multiple closed-loop provision 5	Range: 0.00~10.00V	0.00V
F11.28	Multiple closed-loop provision 6	Range: 0.00~10.00V	0.00V
F11.29	Multiple closed-loop provision 7	Range: 0.00~10.00V	0.00V

Among the closed-loop reference channel, besides the 7 channels defined by F11.01, The closed-loop reference can also be defined in F11.23~F11.29. The priority of multi-closed-loop reference control is higher than the reference channels that defined by F11.01.

Multi-closed-loop reference 1~7 can be selected by external terminals. Please refer to the terminal function 19~21 of introductions to F08.18~F08.25. When the function of Constant water supply is enable, the reference of constant water pressure is decided by the multi-closed-loop reference which selected by external terminals.

Computational formula: constant pressure reference = F12.06 × Multi-closed-loop reference/10.00V. By using this functions can realize different times with a different constant water pressure.

7.13 Constant pressure water supply function parameters Group: F12

F12.00	Constant pressure water supply mode selection	Range: 0~5	0
--------	---	------------	---

0: Disabled.

1: Single pump constant pressure water supply mode.

2~4: Reserved.

5: Select inverter Y1, Y2 as the double pump timing alternate constant pressure water supply mode. While F12.00=5, F09.00=37, F09.01=38, realize the timing alternate constant pressure water supply control between two pumps, only one motor is running at most at any time, the time of timing alternate is defined by F12.10. While F12.10=0, no alternate control, While F12.10=1, switch a running pump while starting.

When modify F12.00 from 0 to water supply mode is valid, C-04, C-05

automatically relate constant pressure water supply setting pressure and feedback pressure (Including the display of halting and running).

When F12.00 is set from 0 to 5, F09.00 is automatically associated with 37 and F09.01 is automatically associated with 38 to facilitate customer operation.



Note

- (1) The function of Group F11 will be effective automatically when the constant pressure supply function is enabled.
- (2) Except for the related parameters in Group F11 and F12 for Closed-loop, the function of Yi (ie F09.00=37、 F09.01=38) should be enabled in F09 for the inverter works in one-drive-two-pump mode without an extend board.
- (3) Output terminal Y2/DO should be set to Y2.
- (4) When one inverter drive one pump with constant pressure water supply, The parameter F09.00~F09.03 (Y1,Y2) can't be set 37, 38.

F12.01	Target pressure setting	Range: 0.000~The range of long-distance manometer	0.200Mpa
---------------	--------------------------------	--	-----------------

This parameter defined the target pressure of the constant pressure supply system.

The channels of the pressure reference and feedback are defined by F11.01 and F11.02.

F12.02	Sleep frequency threshold	Range: 0.00Hz~upper limit frequency	30.00Hz
F12.03	Revival pressure threshold	Range: 0.000~F12.06 Mpa	0.150Mpa

Sleep frequency threshold function: When the system water supply pressure is within the range of F11.11 (deviation limit), and the inverter's operating frequency is below the value of F12.02 (sleep frequency), when F12.04 (sleep delay time) has passed After that, the inverter will enter the sleep state and the operating frequency will be reduced to 0.00Hz to achieve the purpose of energy saving and motor protection.

When the sleep frequency threshold function is to be realized, F01.13 should be set to 3, and F12.04 is greater than 0.

Revival function: When the system is in the sleep mode, if the feedback water pressure keep less than F12.03 (The revival pressure) a delay time (F12.05), the system will revival from the sleep mode.

F12.04	Sleep delay time	Range: 0.0~6000.0s	0.0s
---------------	-------------------------	---------------------------	-------------

This parameter is the delay time that from the feedback pressure meets the sleep conditions to the system enter in sleep mode.

Within the sleep delay time, if the feedback pressure does not meet the sleep conditions, the system will not enter into sleep mode.

When F12.04=0, the sleep function is invalid.

Sleep function is disabled when F12.04=0.

F12.05	Revival delay time	Range: 0.0~6000.0s	0.0s
---------------	---------------------------	---------------------------	-------------

When the constant pressure supply system in the sleep state, if the feedback pressure of system less than F12.11 which defined the revival pressure threshold ,the system will revival and get out of sleep mode after the revival delay time.

F12.06	The range of long-distance manometer	Range: 0.001~9.999Mpa	1.000Mpa
---------------	---	------------------------------	-----------------

This parameter defines the range value of the connected pressure gauge, which corresponds to the maximum value when the connected pressure gauge is converted into a voltage or current signal.

F12.07 ~ F12.09	Reserved		
-------------------------------------	-----------------	--	--

F12.10	Automatic switching time interval	Range: 0000~65535 minute	0
---------------	--	---------------------------------	----------

By setting this parameter can avoid the rust of motor when it's not work long time. The inverter will switch the work status of the working pump and static pump automatically and smartly under the switch interval.

The automatic switch function is disabled when set the parameter as 0000. The system will switch one time when each restart of system as this parameter is 0001. If the value of this parameter is bigger than 0002, the system will switch automatically according the switch interval.

F12.11	Revival mode selection	Range: 0,1	0
F12.12	Revival pressure coefficient	Range: 0.01~0.99	0.75

When F12.11=0, the revival pressure of the constant pressure supply is the value of F12.03.

When F12.11=1, the revival pressure is the calculating value of F12.12*F12.01

F12.13	Reserved		
---------------	-----------------	--	--

F12.14	Water shortage protection mode	Range: 0~2	0
F12.15	Water shortage protection current	Range: 10%~150%	80%
F12.16	Wake up time again after water shortage protection	Range: 0~3000min	60min

7 Detailed function specification

F12.17	Water shortage protection judgment time	Range: 1.0~100.0s	5.0s
--------	---	-------------------	------

When F12.14=1, the water shortage judgment is determined by the multi-function terminal X signal, function 70: water shortage signal input, function 71: have water signal input, when the water shortage fault is detected, at the time defined by F12.16, if water input (No.71 function) is detected, it will automatically reset and run again.

When F12.14=2, The water shortage is judged after the inverter runs and whether the output frequency of PID regulation reaches the upper limit of PID output frequency F11.15, and after the judgment of F12.17 time. If the inverter output current is less than the current value defined by F12.15*motor rated current (F15.03), The inverter reports E-42 water shortage fault, then delays F12.16 time, automatically resets and runs again, If the fault reset is pressed during the fault, the inverter needs to give the running command again. When E-42 fault occurs, the fault automatic reset function defined by F19.01 and F19.02 is invalid.

7.14 Traverse, Fixed-length control Function Parameters Group: F13

F13.00	Traverse function selection	Range: 0,1	0
--------	-----------------------------	------------	---

0: Disabled

1: Enabled

F13.01	Traverse operating mode	Range: Unit digit: 0,1 Tens digit: 0,1 Hundreds digit: 0,1 Thousands digit: 0,1	0000
--------	-------------------------	--	------

Unit digit: Start mode 1st

0: Auto start. The drive operates at the preset frequency of traverse for a certain time thereafter enter traverse mode automatically.

1: Terminal manual mode. Choosing multi-function terminal ($X_i = X1 \sim X5, A11, A12$) as 56 function, when the terminal is enabled, the drive will enter traverse mode. The drive will exit traverse operation and operate at the pre-set traverse frequency when it's disabled.

Tens digit: Traverse amplitude AW mode choosing

0: Variable swing. Amplitude AW changes with the central frequency and the change rate relate to the definition of F13.02.

1: Fixed swing. Traverse operating amplitude AW is determined by Upper limit Frequency and F13.02.

Note: The traverse central frequency is set by the main frequency.

Hundreds digit: Restart mode

0: Restart at the initial state.

1: Restart at the memorized state before stopping

Thousands digit: Traverse state saving when power off.

This function is effective when the start mode is Restarting from the reserved memory state, and saving operating state when power off.

0: Not save

1: Save



Note

When in variable amplitude mode, the channel of central frequency is confirmed by F01.06. During the traverse frequency operation, the Acc and Dec time are controlled only by traverse frequency circle F13.04 when adjusting the central frequency.

F13.02	Traverse frequency swing value	Range: 0.0~50.0%	10.0%
--------	--------------------------------	------------------	-------

Variable amplitude: $AW = \text{the central frequency} \times F13.02$

Fixed amplitude: $AW = \text{Upper limit frequency} \times F13.02$



Note

The traverse operating frequency is restricted by the upper and lower limit of frequency. Incorrectly setting the frequency will lead to abnormal of traverse operation.

F13.03	Sudden-jump frequency	Range:0.0~50.0%	2.0%
--------	-----------------------	-----------------	------

As shown in Fig.7-43, there is not a jitter frequency when F13.03=0.

F13.04	Traverse cycle	Range:0.1~999.9s	10.0s
--------	----------------	------------------	-------

F13.04 defines a complete cycle of traverse operation which including rising and falling processed.

F13.05	Triangular wave rising time	Range:0.0~98.0%(Traverse cycle)	50.0%
--------	-----------------------------	---------------------------------	-------

Definition traverse rising time= $F13.04 \times F13.05$ (s), the traverse falling time= $F13.04 \times (1-F13.05)$ (s). Please refer to Fig.7-43

F13.06	Preset frequency of Traverse	Range:0.00~400.00Hz	0.00Hz
--------	------------------------------	---------------------	--------

F13.06 defines the operating frequency of the Drive before entering traverse operation.

F13.07	Traverse preset frequency waiting time	Range:0.0~6000.0s	0.0s
--------	--	-------------------	------

F13.07 defines the operating time of Preset frequency before entering Traverse operation when auto-start mode is enabled. If manual start mode is available, F13.07 is disabled. Please refer to Fig.7-43 as below.

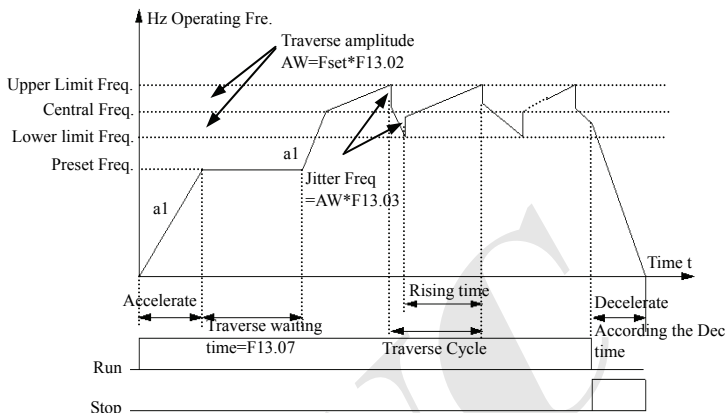

Fig.7-43 Traverse operation

F13.08	Setup length	Range: 0~65535 (m\cm\mm)	0
F13.09	Pulse No. of axis per circle	Range: 1~10000	1
F13.10	Axis perimeter	Range: 0.01~655.35cm	10.00cm
F13.11	Percentage of remaining length	Range: 0.00%~100.00%	0.00%
F13.12	Length correction coefficient	Range: 0.001~10.000	1.000

Set length, actual length and Numbers of pulses per cycle are used for fixed length control. The Actual length is calculated by the number of pulses collected by terminal Xi ($i=1\sim 5$, AI1, AI2), set the Xi function code to 62 and length signal output.

Actual length=(Actual number of pulses \times F13.10 \times F13.12)/F13.09, When the actual record length (F00.02 = 39) $>$ set length(F13.08), after the time defined by F13.07, The "reach length" signal can be output via Yi and the relay output terminal for 0.5 seconds. When remaining length ratio $<$ F13.11, The drive will run at the frequency defined by F13.06 until the length is reached. With this function, the overshoot of the stop can be prevented to increase the accuracy of the fixed length control. When this parameter equals 0.00%, this function is invalid. (This function is valid only when the current frequency is the primary auxiliary).



Note

(1) When F00.02=39, Actual length can be monitored by C-01 in running state. Count length function is available both V/F control mode and Vector Control mode.

(2) Using X5 port as a fixed length count input, the maximum input value is 1K. Using X1~X4 port as a fixed length count input, the maximum input value is 50Hz.

F13.13	Record length when the length is reached	Range: Units digit: Reserved Tens digit: 0,1,2 Hundreds digit: 0,1,2 Thousands digit: 0,1,2	0000
--------	--	---	------

Units digit: Reserved

Tens digit: Sets the unit of length

0: Meter (m)

1: Centimeter (cm)

2: Millimeter (mm)

Hundreds digit: Actions when the length is reached

0: Continue running

1: Shut down according to stopping mode

2: Loop length control

Thousands digit: Software reset length (Could be cleared by communication)

0: No operation

1: The current length is cleared

2: The current length and total length both cleared

F13.13 tens digit determines the unit of length in F13.08, 0=m, 1=cm, 2=mm.

According to the process requirements to select different units can increase the accuracy of fixed-length control.

F13.13 Hundreds digit determine the action of the drive when reach the length. 0 = Continue running, 1 = Shut down according to stopping mode, 2 = Loop length control. When 2 is selected, the frequency will run for 0 frequency and continue for the next fixed time after the time defined by F13.04. This function is effective only when the frequency is the main auxiliary reference, for example jogging, PLC, process PID. This function is only available when the reference of a higher priority is invalid.

F13.13 Thousands digit: The upper computer can change the current length and the cumulative length by changing thousands digit of F13.13. Note that F13.13 can not be wrongly modify the other bits, such as F13.13 units, tens, hundreds were 1,1,0, then F13.13 should be set to 0x1110 or 0x2110. When the multi-function input terminal No. 63 is valid, both the current length and the accumulated length are

cleared.

F13.14	Record length at shutdown	Range: Units digit: 0,1 Tens digit: 0,1 Hundreds digit: 0,1	011
---------------	----------------------------------	--	------------

Units digit: Stops the current length

0: Automatically cleared

The current record length is automatically cleared at shutdown.

1: Length is maintained

The current record length remains unchanged during shutdown.

Tens digit: Power-down length memory setting

0: Not stored

1: Stored

This digit controls the current length of the power-down storage feature, but the cumulative length of the power-down will be stored.

Hundreds digit: length calculation at shutdown

0: The length is not calculated

1: Calculate the length

When this digit is 1, the length calculation module will automatically calculate the length according to the external pulse when the inverter is shutdown.

7.15 Vector Control parameters Group: F14

F14.00	Speed/Torque control selection	Range: 0,1	0
---------------	---------------------------------------	-------------------	----------

0: Speed control mode

1: Torque control mode.

This parameter can be used to select speed control or torque control. Both asynchronous motor and synchronous motor vector control can select the control mode through this parameter. At the same time, the control mode can be selected through the multi-function input terminal No. 65 function.

F14.01	High speed proportional gain of asynchronous motor speed loop	Range: 0.1~40.0	20.0
F14.02	High speed integral time of asynchronous motor speed loop	Range: 0.001~10.000s	0.040s
F14.03	Low speed proportional gain of asynchronous motor speed loop	Range: 0.1~80.0	20.0
F14.04	Low speed integral time of asynchronous motor speed loop	Range: 0.001~10.000s	0.020s
F14.05	Parameter switching frequency of asynchronous motor speed loop	Range: 0.00Hz~20.00Hz	5.00Hz

The speed response characteristics under vector control can be improved by adjusting the gain and integration time of the speed loop at high and low speeds.

Increasing the proportional gain and reducing the integration time can speed up the dynamic response of the speed loop. However, if the proportional gain is too large or the integral time is too small, the system may oscillate. The recommended adjustment method as below: if the factory parameters can't meet the requirements, make fine adjustments based on the factory value parameters. Firstly increase the proportional gain to ensure that the system does not oscillate, then reduce the integration time to make the system has both faster response characteristics and smaller overshoot.

The above parameters are valid in asynchronous motor open loop speed control mode, but invalid in torque control and V/F mode.

F14.06	Asynchronous motor low frequency power generation stability coefficient	Range: 0~50	25
---------------	--	--------------------	-----------

When the motor connected to frequency inverter under a low frequency generating status, Please adjusting this parameter appropriately.

For example, the frequency inverter will be unstable when drives a potential load which is declining gradually. Increasing F14.06 will improve the stability of the system.

F14.07	Asynchronous motor current loop proportional gain	Range: 1~500	150
F14.08	Asynchronous motor current loop integral time	Range: 0.1~100.0ms	4.0ms

F14.07 and F14.08 are the PI regulator parameters of Current loop.

The system torque dynamic response can be faster if the Current loop proportional gain P is increased or Current loop integral time constant Ti is decreased.

The system stability can be improved if the Current loop proportional gain P is decreased or integral time constant Ti is increased.

In general, the above parameters don't need change.

F14.09	Asynchronous motor speedless vector slip gain	Range: 50%~200%	100%
---------------	--	------------------------	-------------

It is valid for asynchronous motor (F15.00=0) speedless sensor vector control (F00.24=1). This parameter is used to adjust the motor's speed stabilization accuracy. When the speed of the loaded motor is too low, increase this parameter, or decrease it.

F14.10	Asynchronous motor low frequency slip gain	Range: 30%~300%	100%
---------------	---	------------------------	-------------

It is valid for asynchronous motor (F15.00=0) speedless sensor vector control (F00.24=1). Adjusting this parameter appropriately can improve the accuracy of low-frequency speed.

7 Detailed function specification

F14.11	Asynchronous motor field weakening control coefficient	Range: 20.0~100.0%	80.0%
---------------	---	---------------------------	--------------

Function code F14.11 revises the field weakening curve in the field weakening zone. By modifying the field weakening curve, the speed control accuracy of the field weakening zone can be improved and the field weakening frequency can be increased.

F14.12	Asynchronous motor over modulation coefficient	Range: 95%~115%	100%
---------------	---	------------------------	-------------

Under the situation of field weakening (only F00.24=1 is valid), appropriately increasing this parameter can reduce the output current and increase the field weakening frequency, but if this parameter is too large, the harmonics of several degrees of current will increase.

F14.13	Asynchronous motor flux braking coefficient	Range: 0.0~300.0%	0.0%
---------------	--	--------------------------	-------------

Under open-loop and closed-loop speed control mode, increasing the strength of the field can realize fast decreasing of the motor when stop. The energy generated during the field braking process will be consumed in a form of heat inside of the motor. As a result, the temperature of motor inside will increase when field braking frequently. Please care about the temperature of the motor not over the allowed maximum value. If an operation command be given during the process of field braking, the field braking function will be canceled and the frequency inverter will operate to the set frequency again. Please disable the field braking function when using braking resistor.

F14.14	Asynchronous motor pre-excitation start time constant	Range: 0.1~3.0	0.5
---------------	--	-----------------------	------------

In SVC control mode, decrease the value of F14.25 appropriately will decrease the start time of the motor, realizing fast start performance.

F14.15 ~ F14.18	Reserved		
-------------------------------------	-----------------	--	--

F14.19	Electric torque current limit value	Range: 0.0~250.0%	160.0%
F14.20	Braking torque current limit value	Range: 0.0~250.0%	160.0%

It is the range of output torque of speed loop defined by the positive torque and negative torque limit. When the application needs quick acceleration and deceleration, this parameter can be appropriately increased to meet the specific requirements. However, if it's too large, the drive tends to over-current.

In torque control mode, the range of actual torque output is restricted to the above limit too.

F14.21	Torque setting and limited channel selection	Range: Unit digit: 0~8 Tens digit :0~8 Hundreds digit: 0~8	000
--------	--	--	-----

Units digit: Torque provision channel selection

0: Digital setting (Determined by F14.23).

1: AI1 analog provision (0~10V corresponds to 0~200.0% motor rated torque current)

2: AI2 analog provision (0-10V or 0-20mA corresponds to 0~200.0% Rated torque current of the motor)

3: Terminal UP/DOWN adjusting

4: Communication provision (Communication address: 1D01). (0~10000 corresponds to 0~200.0% Rated current of the motor)

5, 6: Reserved

7: High speed Pulse provision (Please choose the related function of X5)

8: Terminal width provision (Please choose the related function of X5)

The range of the above channels which from the Min value to the Max value corresponds to 0.0~200% Rated torque current of motor.

Tens digit: Electric torque limit channel selection

0: Digital setting (Determined by F14.19)

1: AI1 analog setting

2: AI2 analog setting

3: Terminal UP/DOWN adjustment setting

4~6: Reserved

7: High-speed pulse setting

(X5 terminals need to select the appropriate function)

8: Terminal pulse width setting

(X5 terminals need to select the appropriate function)

Note: The maximum value of 1~ 8 channels corresponds to F14.19

Hundreds digit: Braking torque limit channel selection

0: Digital setting (Determined by F14.20)

1: AI1 analog setting

2: AI2 analog setting

3: Terminal UP / DOWN adjustment setting

4~6: Reserved

7: High-speed pulse setting

(X5 terminals need to select the appropriate function)

8: Terminal pulse width setting

(X5 terminals need to select the appropriate function)

Note: The maximum value of 1 ~ 8 channels corresponds to F14.20

When the torque limit value is modified by communication, the torque channel must be set to digital setting (Tens or hundreds digit are 0). Torque limitation can be

performed by directly modifying F14.19 or F14.20 by communication. The shutdown and power-down storage function are affected by F01.03 and F01.05 when terminal UP / DOWN is adjusted. If stop is not restored and power-down is saved, F01.03 = 3 and F01.05 = 00 need to be set.

F14.22	Torque polarity setting	Range: 0000~2112	2000
--------	-------------------------	------------------	------

Unit digit: Polarity of Torque reference

0: Positive

1: Negative

2: Defined by running c=0, The torque direction is determined by the polarity of AI2.

Tens digit: Polarity of Torque compensation

0: Same direction with torque reference

1: Opposite direction with torque reference

F14.22 determines the polarity of the given torque and compensation torque. At the same time, the torque given direction can be dynamically switched through the multi-function key.

Hundreds digit: F14.29 compensation weakened when the motor locked rotor

0: Invalid

1: Enable. This function prevents belt slippage caused by low frequency compensation F14.29 set too large or torque set too large and motor locked rotor.

Thousands digit: Torque control anti-reverse function

0: Invalid

1: Anti-reverse function is active continuously

2: Anti-reversal function enabled at startup. Only the start-up moment has anti-reverse function.

F14.23	Torque digital setting value	Range: 0.0~200.0%	0.0%
--------	------------------------------	-------------------	------

When the units digit F14.21=0, the value of torque provision is set by F14.23. A 100.0% value of F14.23 corresponds to the rated current of motor. The actual output torque will be decreased when the motor under a weaken field status. When choosing digital setting, press up and down keypad can revise the torque value.

F14.24	Forward speed limit channel selection in torque control mode	Range: 0~8	0
--------	--	------------	---

0: Digital setting

1: AI1 analog provision

2: AI2 analog provision

3: Terminal UP/DOWN adjusting

4: Communication provision (Communication address: 1D0A).

5, 6: Reserved.

7: High speed Pulse provision (Please choose the related function of X5)

8: Terminal width provision (Please choose the related function of X5)

When positive torque provided, if the load torque is smaller than the output torque, the motor's rotational speed will rise forward continuously to the forward frequency limit defined by limit channel (F14.24), so as to avoiding runaway of the motor.

F14.25	Reverse frequency limit channel selection in torque control mode	Range: 0~8	0
---------------	---	-------------------	----------

0: Digital setting

1: AI1 analog provision

2: AI2 analog provision

3: Terminal UP/DOWN adjusting

4: Communication provision (Communication address: 1D0B).

5, 6: Reserved.

7: High speed Pulse provision (Please choose the related function of X5)

8: Terminal width provision (Please choose the related function of X5)

When negative torque provided, if the load torque is smaller than the output torque, the motor's rotational speed will rise reverse continuously to the reverse frequency limit defined by limit channel (F14.25),so as to avoiding runaway of the motor.

F14.26	Forward Speed limit in Torque control mode	Range: 0.00Hz~Upper limit freq.	50.00Hz
F14.27	Reverse Speed limit in Torque control mode	Range: 0.00Hz~Upper limit freq.	50.00Hz

When F14.24=0, F14.25=0, the related limit frequency of the positive torque or negative torque are confirmed by F14.26 and F14.27.

F14.28	Acc and Dec time of torque provision	Range: 0.000~60.000s	0.100s
---------------	---	-----------------------------	---------------

The torque provision from the provision channel will form the final torque provision after the Acc and Dec time of F14.28.Suitable value of F14.28 can avoid vibration of the motor which caused by saltation of torque provision.

F14.29	Torque compensation	Range: 0.0~100.0%	0.0%
---------------	----------------------------	--------------------------	-------------

Tens digit of F14.22 and F14.29 determine the torque compensation polarity and offset. Normally, it is not necessary to set the torque compensation when the torque loss due to the mechanical loss of the motor is large. When the set value is 100%, it corresponds to the rated torque current of the motor. When the reference torque is less than 1.1% of rated torque, the torque compensation value defined in F14.29 is invalid.

F14.30	Torque compensation limit frequency	Range: 0.00Hz~Upper limit Freq.	20.00Hz
---------------	--	--	----------------

7 Detailed function specification

When the output frequency is bigger than the value of F14.30, the torque compensation defined by F14.21 is 0. And the actual torque compensation will linearly decrease from 0Hz to the frequency of F14.30.

F14.31	Positive torque gain regulation coefficient	Range: 50.0~150.0%	100.0%
F14.32	Negative torque gain Regulation coefficient	Range: 50.0~150.0%	100.0%

When choosing positive torque provision, adjusting F14.31 will correct the matching of the actual output torque and the torque provision if they are unmatched.

When choosing negative torque provision, adjusting F14.32 will correct the matching of the actual output torque and the torque provision if they are unmatched.

F14.33	Reserved		
F14.34	Reserved		

F14.35	Synchronous motor field weakening control method	Range: 0~2	1
---------------	---	-------------------	----------

0: Direct calculation

1: Automatic adjustment

2: Not weakening

F14.36	Synchronous motor field weakening current coefficient	Range: 0~120%	80%
---------------	--	----------------------	------------

The actual field weakening current is equal to the theoretically required field weakening current multiplied by the field weakening current coefficient. The larger the setting of F14.36, the larger of the field weakening current, and the better dynamic effect of the motor after field weakening. If it is too large, it will easily cause oscillation. Generally set to 80%.

F14.37	Synchronous motor weakening adjustment coefficient	Range: 1~10	4
---------------	---	--------------------	----------

It is effective when the field weakening control mode is automatic adjustment. Used to set the speed of adjusting the weakening current. The larger F14.37 is the faster the field weakening current can be adjusted, and it can quickly approach the required minimum field weakening current. If it is too large, it will easily cause oscillation. Generally set to 4.

F14.38	Synchronous motor field weakening output voltage adjustment coefficient	Range: 0~100	40
---------------	--	---------------------	-----------

Used to adjust the voltage output value during field weakening, generally set to 40. The larger F14.38 is the higher the output voltage and the smaller the current

when the field is weakened.

F14.39	Synchronous machine high-speed PI adjustment integral coefficient	Range: 0~6000	150
F14.40	Synchronous machine high-speed PI adjustment proportional coefficient	Range: 0~6000	60
F14.41	Synchronous machine low-speed PI adjustment integral coefficient	Range: 0~6000	150
F14.42	Synchronous machine low-speed PI adjustment proportional coefficient	Range: 0~6000	60
F14.43	Synchronous machine speed PI switching frequency point 1	Range: 0.00~F14.44	1.00Hz
F14.44	Synchronous machine speed PI switching frequency point 2	Range: 0.00~upper limit freq.	2.00Hz

The above parameters are used to adjust the high speed and low speed speed loop PI of the synchronous machine. Increasing the integral coefficient and proportional coefficient will speed up the speed response, but too large will cause speed oscillation and increase overshoot. If adjustment is necessary, first reduce the integral coefficient, increase the ratio when the speed is not oscillating, and increase the integral coefficient if the effect is not satisfactory. Generally, the greater the moment of inertia of the system, the greater the integral coefficient and proportional coefficient. The larger the speed filter coefficient is set, the smaller the integral should be set, and the ratio can be increased appropriately. The larger ratio of the rated torque of the motor to the load weight, the smaller the integral and proportional coefficient settings.

Less than the frequency range of F14.43, the speed PI parameters are set by F14.41 and F14.42. If the frequency range is bigger than F14.44, the speed PI parameters are set by F14.39 and F14.40. The intermediate frequency is set according to a linear change.

F14.45	Synchronous machine speed filter coefficient	Range: 4~512	56
--------	--	--------------	----

Used to set the speed feedback filter coefficient, generally set to 56.

F14.46	Synchronous machine low speed filter coefficient	Range: 4~512	16
--------	--	--------------	----

Set the speed filter coefficient below the F14.43 frequency, generally set to 16.

F14.47	Synchronous machine low-speed carrier frequency	Range: 2.0~10.0K	2.0K
--------	---	------------------	------

Used to set the low-speed carrier frequency, the unit is 0.1KHZ, generally set to 2.0K.

F14.48	Synchronous machine recognizes back-EMF	Range: 0~100%	30%
--------	---	---------------	-----

7 Detailed function specification

	current/Low speed minimum current		
--	--	--	--

During parameter identification, set the motor running current as a percentage of the rated current when the motor identifies the back-EMF coefficient, If the motor does not rotate when identifying the back-EMF coefficient, the current must be increased. It is used to set the minimum output current at low speed during normal operation, For the frequency range where the output voltage is less than 20V, a certain minimum current is required for the motor to operate normally.

F14.49	Reserved		
---------------	-----------------	--	--

F14.50	Synchronous machine speed estimation parameter 1	Range: 1~1000	20
F14.51	Synchronous machine speed estimation parameter 2	Range: 1~1000	30

These two speed estimation parameters are debugging parameters, users should not change them.

F14.52	Synchronous machine start preset current	Range: 0~200	0
---------------	---	---------------------	----------

The torque current at startup is preset as a percentage of the rated current.

F14.53	Synchronous machine start initial position detection method	Range: 0, 1	0
---------------	--	--------------------	----------

0: Do not detect the initial position

1: Detect initial position method

If you need to detect the initial test position, first set it to 1.

F14.54	Synchronous machine starts initial position detect pulse current	Range: 0~200%	120%
---------------	---	----------------------	-------------

The magnetic pole position detection current is a percentage of the rated current. Usually set to 120. This parameter will affect the identification result of F14.59.

F14.55	Synchronous machine D axis current PI adjustment integral coefficient	Range: 0~6000	200
F14.56	Synchronous machine D axis current PI adjustment proportional coefficient	Range: 0~6000	300
F14.57	Synchronous machine Q axis current PI adjustment integral coefficient	Range: 0~6000	200
F14.58	Synchronous machine Q axis current PI adjustment proportional coefficient	Range: 0~6000	300

Synchronous machine current loop PI adjustment. Increasing the integral coefficient and proportional coefficient will speed up the current response speed, but too large will cause speed oscillation and increase overshoot. If adjustment is required, adjust the proportional coefficient first, and then adjust the integral coefficient if the effect is not satisfactory.

F14.55, F14.56, F14.57, F14.58, F14.59 will be automatically set after parameter identification, and generally do not need to be changed by the user. For small inductance motors, you need to manually increase the settings of F14.55, F14.56, F14.57, and F14.58.

F14.59	Synchronous machine initial position detection time	Range: 0~60000	0
---------------	--	-----------------------	----------

It is the initial position detection time, which is automatically detected by the current set by F14.54, without manual modification.

F14.60 ~ F14.69	Reserved		
-------------------------------------	-----------------	--	--

7.16 Motor parameters Group: F15

F15.00	Motor type	Range: 0,1	0
---------------	-------------------	-------------------	----------

0: Asynchronous motor

1: Synchronous motor

F15.01	Asynchronous motor rated power	Range: 0.1~6553.5KW	Depend on type
F15.02	Asynchronous motor rated voltage	Range: 1~690V	Depend on type
F15.03	Asynchronous motor rated current	Range: 0.1~6553.5A	Depend on type
F15.04	Asynchronous motor rated frequency	Range: 0.00~600.00Hz	Depend on type
F15.05	Asynchronous motor rated rotational speed	Range: 0~60000r/min	Depend on type
F15.06	Number of motor pole pairs	Range: 1~100	2

Set the parameters according to the motor nameplate no matter whether V/F control mode or open loop vector control mode is adopted, otherwise it may be abnormal. To achieve better performance, motor auto-tuning is required. Before parameter tuning, the above rated motor parameters must also be set correctly, otherwise the tuning result may be wrong.

7 Detailed function specification

F15.07	Asynchronous motor Stator resistance	Range: 0.001~65.535Ω(AC drive power<7.5KW)	Depend on type
		Range: 0.0001~6.5535Ω(Ac drive power≥7.5KW)	
F15.08	Asynchronous motor Rotor resistance	Range: 0.001~65.535Ω(AC drive power<7.5KW)	Depend on type
		Range: 0.0001~6.5535Ω(Ac drive power≥7.5KW)	
F15.09	Asynchronous motor leakage inductance	Range: 0.01~655.35mH(AC drive power<7.5KW)	Depend on type
		Range: 0.001~65.535mH (AC drive power≥7.5KW)	
F15.10	Asynchronous motor mutual inductance	Range: 0.1~6553.5mH (AC drive power<7.5KW)	Depend on type
		Range: 0.01~655.35mH (AC drive power≥7.5KW)	
F15.11	Asynchronous motor no-load current	Range: 0.01~655.35A	Depend on type

F15.07~F15.11 is the characteristic parameters of asynchronous motor, not display on the nameplate, which need detected by auto-tuning. To achieved a good control performance, please let the motor unload before start rotating auto-tuning. For the asynchronous motor that cannot be disconnected from the load, you can choose static auto-tuning or input the motor parameters manually. Another way is just set F15.01 and used the default parameters in F15.01~F15.11.

F15.12	Synchronous motor stator resistance	Range: 0.001~65.535Ω(Inverter power<7.5KW)	Based on type
		Range: 0.0001~6.5535Ω(Inverter power≥7.5KW)	
F15.13	Synchronous motor D axis inductance	Range: 0.01~655.35mH (Inverter power<7.5KW)	Based on type
		Range: 0.001~65.535mH(Inverter power≥7.5KW)	
F15.14	Synchronous motor Q axis inductance	Range: 0.01~655.35mH (Inverter power<7.5KW)	Based on type
		Range: 0.001~65.535mH(Inverter power≥7.5KW)	
F15.15	Synchronous motor back EMF coefficient	Range: 0~6000	Based on type

F15.12~F15.15 are the parameters of the synchronous motor. These parameters are generally not on the motor nameplate and need to be obtained through automatic tuning of the inverter. In order to obtain better control performance, it is necessary to perform rotation tuning after the motor is off-axis. Can choose static tuning in situations where it cannot be off-axis. During static adjustment, F15.15 will not be updated, the user can manually input after calculating according to F15.02 and F15.04.

$$F15.15=100*F15.02/F15.04,$$



For example, $F15.02=380V$, $F15.04=50.00Hz$, then $F15.15=100*380/50=760$.

F15.16 ~ F15.18	Reserved		
-----------------------	----------	--	--

F15.19	Motor parameter auto-tuning selection	Range: 0x00~0x12	00
--------	---------------------------------------	------------------	----

0: No action

1: Static auto-tuning

It is applied to applications where the motor cannot be disconnected from the load or the process is complicated. Values on the motor's nameplate should be input correctly before starting auto-tuning (F15.01~F15.06), Set F15.19 as 1 and press , back to monitoring mode, then press  to start auto-tuning which with a "tune" symbol on the keyboard.

After auto-tuning, the Drive will exit process automatically and the detected values of the stator's resistance, rotor's resistance and the leakage inductance will be saved in F15.07-F15.09.



In static auto-tuning mode, the value of No-load current and mutual inductive reactance will not be detected. The user can input the related values with the reference of the Motor factory data or the data on the motor test report. Without related value, please adopt the Default value. Otherwise it may cause negative influence on the performance of motor.

During the process of auto-tuning, any abnormal please press  to stop auto-tuning.

2: Rotating auto-tuning of Asynchronous motor

If the load of the motor is less than 30% of the rated load or the load inertia is large but the load is not heavy, you can choose to perform rotation auto-tuning. But please try to disconnect the load and keep the motor in a static and no-load state, otherwise the tuned parameters may be incorrect. When the motor wire is connected, when rotating and setting, the motor is running in the wrong direction (unfavorable to the equipment or the load is large when the current direction is running), you can set the hundreds digit of F01.16 to 1, and perform reverse rotation setting. And it is



necessary to manually restore the original setting of F01.16 after setting.

Values on the motor's nameplate should be input correctly before starting auto-tuning (F15.01-F15.06), Set F15.19 as 2 and press , back to monitoring mode, then press  to start auto-tuning which with a "tune" symbol on the keyboard. When rotation setting after the motor line is connected, the motor runs in the wrong direction (Negative for the device or the load is larger in the current direction). You can set F01.16 hundreds digit to 1 running reverse direction rotation tuning. The F01.16 settings need to be manually restored after setting.

After auto-tuning, the Drive will exit process automatically and the detected values of the stator's resistance, rotor's resistance, the leakage inductance, No-load current and mutual inductive reactance will be saved in F15.07-F15.11.

During the process of auto-tuning, any abnormal please press  to stop auto-tuning.

11: Synchronous machine static self-tuning.

When the motor cannot be disconnected from the load or the process of disconnecting the load is cumbersome, please choose to perform static auto-tuning. Before auto-tuning, input the motor nameplate parameters (F15.00~F15.06) correctly, set F15.19 to 11, press the  key, and then return to the monitoring window and press the  key to start auto-tuning. At this time, the keyboard displays "tune".



After the auto-tuning is over, the inverter will automatically exit and store the tuned stator resistance, D-axis inductance and Q-axis inductance in the parameters F15.12~F15.14.

F15.15 cannot be set, the user can manually input after calculation according to F15.02 and F15.04, $F15.15=100 \times F15.02 / F15.04$, for example, $F15.02=380V$, $F15.04=50.00Hz$, Then $F15.15=100 \times 380 / 50=760$.

During the tuning process, if an abnormality occurs, the user can press the  key to finish the parameter auto tuning.

12: Synchronous machine rotating and self-tuning.

If the load of the motor is less than 30% of the rated load or the load inertia is large but the load is not heavy, you can choose to perform rotation auto-tuning. But please try to disconnect the load and keep the motor in a static and no-load state, otherwise the tuned parameters may be incorrect. When the motor wire is connected, and during rotation adjustment, if the motor runs in the wrong direction (unfavorable to the equipment or the load is large when the current direction is running), please set the hundreds digit of F01.16 to 1, Carry out reverse rotation setting. After setting, you need to manually restore the original setting of F01.16.

Before auto-tuning, input the motor nameplate parameters (F15.00~F15.06) correctly, set F15.19 to 12, press the  key, and then return to the monitoring window and press the  key to start auto-tuning. At this time, the keyboard

displays “tune”. After the auto-tuning is over, the inverter will automatically exit and store the tuned parameters in the parameters F15.12~F15.15.

During the tuning process, if an abnormality occurs, the user can press the  key to finish the parameter auto tuning.

F15.20	Synchronous motor inductance identification coefficient	Range: 0~2	0
--------	---	------------	---

This parameter is for the low-power models with large inductance parameters. Set its value to 1 or 2 to speed up the inductance identified process.

F15.21	Reserved		
F15.22	Reserved		

7.17 Monitoring parameter group: F16

F16.00 ~ F16.79	Reserved		
-----------------------	----------	--	--

7.18 Monitoring parameter 1:F17

F17.00 ~ F17.75	Monitoring parameters	Refer to C-xx definition for details	-
-----------------------	-----------------------	--------------------------------------	---

The F17 group is the monitoring parameter group, and F17.00 to F17.75 correspond to the index number of the monitoring parameter group respectively. Please refer to the definition of F00.01 for the specific correspondence. Users can read the corresponding parameters of F17 group through communication to obtain the required monitoring data.

7.19 Enhanced Control Functions Parameters Group: F18

F18.00	Operation panel control frequency binding	Range: 0~15	0
--------	---	-------------	---

F18.00 can bundle operation panel with frequency reference channels, to achieve synchronous switching.

0: No bundling

1: Keyboard digital provision

2: AI1 analog provision

3: AI2 analog provision

4: Terminal UP/DOWN adjust setting

5: Communication provision (MODBUS and Field Bus used a same

storage registers)

6, 7: Reserved

8: High speed Pulse provision (Please choose the corresponding functions of X5)

9: Terminal pulse-width provision (Please choose the corresponding functions of X5)

10: Terminal encoder provision (Defined by X1 and X2)

11~15: Reserved

Different control command channels can be bundled to the same frequency reference channel. After success bundled, the bundled frequency reference channel have a highest priority and just available for Main frequency bundling.

F18.01	Terminal control frequency binding	Range: 0~15	0
--------	------------------------------------	-------------	---

Please refer to the description of F18.00

F18.02	Communication control frequency binding	Range: 0~15	0
--------	---	-------------	---

Please refer to the description of F18.00

F18.03	Digital frequency integral function selection	Range: Units digit: 0,1 Tens digit: 0,1 Hundreds digit: 0,1,2 Thousands digit: 0,1	0000
--------	---	---	------

Units digit: Keyboard UP/DOWN Integration control

0: Integral function enabled

1: Integral function disabled

Tens digit: Terminal UP/DOWN Integration control

0: Integral function enabled

1: Integral function disabled

This function is used in conjunction with multi-function terminal functions 16, 17.

Hundreds digit: Keyboard shuttle knob enable (Shuttle keyboard effective)

0: The shuttle knob is valid in the monitoring interface

1: The shuttle knob is invalid in the monitoring interface

2: In the monitoring interface, the UP DW and jog dial adjustments are invalid.

Thousands digit: Keypad adjustment of frequency classic mode selection

0: Invalid

1: Valid, adjustment range decided by F18.05

This function should cooperate with 16 and 17 functions of multi-function terminal.

F18.04	Keyboard UP/DOWN integral rate	Range: 0.01~50.00Hz	0.10Hz
--------	--------------------------------	---------------------	--------

When the keyboard UP/DOWN Integration is enabled, if keep adjusting the frequency in the same direction, the Integration effect will be effective, and the Integration rate is determined by F18.04.

This function is suitable for the applications that need adjusting frequency quickly.

F18.05	Keyboard no integral single step's size setup	Range: 0.01~10.00Hz	0.01Hz
---------------	--	----------------------------	---------------

When the keyboard UP/DOWN integral function disabled, the rate of adjusting frequency fixed by the value of F18.05.

F18.06	Terminal UP/DOWN Integral rate	Range: 0.01~50.00Hz	0.20Hz
F18.07	Terminal no integral single step's size setup	Range: 0.01~10.00Hz	0.10Hz

Please refer to the functions of F18.04 and F18.05 for the functions of F18.06 and F18.07.

F18.08	Droop control decline frequency	Range: 0.00~10.00Hz	0.00Hz
---------------	--	----------------------------	---------------

When several drivers drive one load, the function can make the drives share the load equally. When the load of one drive is heavier, the drive will reduce its output frequency to shed part of the load.

This function is suitable for the share of several motors which with a common load. The value of F18.08 is the maximum reduced frequency when the drive reaches the rated power.

F18.09	Setup accumulate power on time	Range: 0~65535h	0
F18.10	Setup accumulate run time	Range: 0~65535h	0

When the actual accumulate operation time reach to the set accumulated operation time (F18.10), the drive will output an indication signal. Please refer to the description of F09.00~F09.04.

F18.09 defined the expected accumulated time of power on from Ex factory.



Note

Power-on time and accumulated run time can be checked by monitoring parameters group C.

F18.11	Timing run function enable	Range: 0,1	0
---------------	-----------------------------------	-------------------	----------

0: Disabled

1: Enabled

F18.12	Timing run stop time	Range: 0.1~6500.0Min	2.0Min
---------------	-----------------------------	-----------------------------	---------------

When F18.11 Timing operation function enabled, the driver will start the timer with inverter start.

The drive will stop automatically and the multi-function Yi (Set Yi as the 33 function) will output an indicator signal when reach to the set stop time.

**Note**

The timer of inverter start form 0 every times, the user can monitor the current operation time through the C or F17 Group.

F18.13	Currently run arrival time	Range: 0.0~6500.0Min	1.0Min
---------------	-----------------------------------	-----------------------------	---------------

When the actual operation time reach to this time, the multi-function Yi (choose Yi as 34 function) will output an indicator signal of “Currently operation time reached”.

F18.14	Keyboard UP/DOWN selection under monitor mode	Range: 0~6	0
---------------	--	-------------------	----------

0: Keyboard frequency provision frequency adjusting

1: PID digital reference value adjusting

2~6: Reserved

When F18.14 =1, UP/DOWN is used to adjust the PID digital reference value in Monitor Mode merely.

When F18.14 =0, UP/DOWN is used to adjust the frequency value not only in Monitor Mode when choose frequency digital reference channel.

F18.15	V/F vibration restrain end frequency	Range: 0.00Hz~upper limit frequency	50.00Hz
---------------	---	--	----------------

In V/F Control mode, when the output frequency of inverter is bigger than the limit frequency, the suppression of F03.12 will be disabled. Adjusting F18.15 can restrain the shake phenomenon of motor in a large range.

F18.16	Advanced control functions	Range: Units digit: Reserved Tens digit: 0, 1 Hundreds digit: 0, 1 Thousands digit: 0, 1 (This parameter is in F00.24=1)	0000
---------------	-----------------------------------	---	-------------

When F18.16 tens digit is 0, the torque limit is set according to the rated current of the inverter. When this bit is 1, it is limited according to the rated torque current of the motor. Take the electric torque as an example: F14.13 tens digit = 1(A11 given), F14.09 = 150.0%, inverter rated current $I_n = 100A$, motor rated current I_m (F15.01) = 90A, motor no-load current I_o (F15.11) = 30A.

When F18.16 tens digit=0, when A11 is maximum, the inverter's maximum output current= $I_n \times F14.09 = 150A$, when F18.16 tens digit=1, when A11 is maximum, the inverter's maximum output current= $\sqrt{F14.09 \times (I_m \times I_m - I_o \times I_o)} + I_o$

=130A.

When hundreds digit of F18.16 is 1, enable below the lower limit frequency fast traverse function. When a hoist load occurs when the hook phenomenon, you can open this function, and appropriately improve the F01.12 parameters, can effectively solve this problem.

When thousands digit of F18.16 is 1, the PWM will be blocked when the torque is less than 1.1% and the motor speed is less than 2Hz in no speed torque control mode, and the motor is in the free state. This function is valid when F00.24 = 1.

F18.17	Cooling fan control selection	Range: Units digit: 0~2 Tens digit: 0,1	10
---------------	--------------------------------------	--	-----------

Units digit: Fan control mode

0: Smart fan

1: Inverter is running all the time after power on

2: No running for fan, but it starts automatically when the temperature is higher than 75 degree.

Tens digit: Speed regulation fan control mode.

0: Smart PWM Speed regulation

1: Running at highest speed.

Under the smart control, after stopping the inverter, if the detection temperature is lower than 35 degree, the fan stop running automatically in 20s.

F18.18	Current detection delay compensation	Range: 0~500	5
---------------	---	---------------------	----------

This parameter generally does not need to be adjusted.

F18.19	Low-order of total power consumption	Range: 0~9999	0
F18.20	High-order of total power consumption	Range: 0~65535	0
F18.21	Correction factor of power consumption calculation	Range: 50.0%~200.0%	100.0%

F18.19 and F18.20 show the total amount of power consumed by the load and the inverter. Similarly, C-x can be set to 59 and 60 to monitor the amount of power consumption by the keyboard. Where F18.20 parameter minimum unit represents 10000KWH, for example F18.19 = 1000, F18.20 = 4, the total power consumption = $4 \times 10000 + 1000 = 41000\text{KWH}$.

Users can also set F18.19 and F18.20 to 0 to restart the calculation of the power consumption; if the calculated power consumption are not correct, the F18.21 parameter can be adjusted, so that the calculated power consumption correspond to actual consumption.

F18.22	V/F separate control voltage reference channel.	Range:0~8	1
---------------	--	------------------	----------

0: Digital setting (Determined by 18.23)

1: AI1 analog setting

2: AI2 analog setting

3: Terminal UP / DOWN adjustment setting

4-6: Reserved

7: High-speed pulse setting (X5 terminals need to select the appropriate function)

8: Terminal pulse width setting (X5 terminals need to select the appropriate function)

Note: The maximum value of 0 ~ 8 channels correspond to the motor rated voltage

When F03.00 = 5, and F00.24 = 0, then running VF separation control. The frequency is given by the original way, the voltage is determined by the F18.22, you can choose digital set, analog set, the terminal UP/DOWN set, etc., can also be directly modified by communication F18.23 to achieve communication set. General induction heating, inverter power, torque motor could be controlled by this way.

F18.23	V/F separate control voltage digital reference	Range: 0.0%~100.0%	0.0%
--------	--	--------------------	------

V/F separate control voltage digital reference. 100.0% corresponds to the rated voltage of the motor.

F18.24 ~ F18.29	Reserved		
-----------------------	----------	--	--

7.20 Protective Relevant Function Parameters Group:F19

F19.00	Power off restart waiting time	Range: 0.0~20.0s (0 indicates disabled this function)	0.0s
--------	--------------------------------	--	------

When the power is off, then power-on, whether this inverter will start automatically after a waiting time.

When F19.00=0.0s, after the power off then power-on, inverter will not start automatic. F19.00≠0.0s, after the power off then power-on again, if all is ready, inverter will run automatically with the start method defined by F02.00 after waiting the time defined by F19.00.



Note

Conditions for repower-on after power-off: it should be in the running status before power-off; there's no fault and running signal maintained when power-on again; there's no other factors which affect normal starting.

F19.01	Fault self-recovery times	Range: 0~10	0
--------	---------------------------	-------------	---

		(0 Indicates no self-recovery function)	
F19.02	Fault self-recovery interval time	Range: 0.5~20.0s	5.0s

When the inverter is running, because of fluctuation of load, faults may happen in some case and it will top to output. In order not to stop the operation of equipment, choosing the recovery functions No alarm, stop in stopping mode. Inverter will recovery to run with speed-checking restart style, within the setting time, if inverter cannot run, then fault protection will begin, stop running. No alarm, when the self recovery times of fault are set to 0, self recovery function stops.



- (1) When using fault self recovery function, and make sure the equipment is permitted and inverter do not enter fault.
- (2) Self recovery function is not effective on fault Protection caused by power-on terminal protection, clock fault, overload and over-heated, output short-circuit, short circuit to ground ,and lack-voltage during running.
- (3) When F19.00≠0,open stop and restart function. We can start this equipment without operators, so be careful to use this function.

F19.03	Motor overload protection action selection	Range: 0~2	2
--------	--	------------	---

When the AC motors is overloaded , this mode of Protection will happen.

0: Alarm, continue operation; It happens with only warning, no motor overload Protection characteristic (used cautiously, at this time, inverter has nothing to do with load motor for overload protection;

1: Alarm, Stop according to the stop mode;

2: Fault, Free stop. When it is over loaded, the output of inverter is block , this AC motor free stop .

F19.04	Motor overload protection coefficient	Range: 10.0~2000.0%	100.0%
--------	---------------------------------------	---------------------	--------

To protect the loading motors with different types from overloading effectively, make sure that the parameter F15.03 (Motor rated current) is set according to the motor nameplate.

The motor overloading time can be adjusted by adjusting F19.04, As shown in Fig.7-46, when the output current of motor equals 150% of motor's rated current, and continues for the time determined by $4\text{min} * F19.04$, then alarm for motor overloading protection. If $F19.04=120.0\%$, then the overloading time is $4\text{min} * 120.0\%=4.8\text{min}$. The minimum overloading time of motor is 5s.

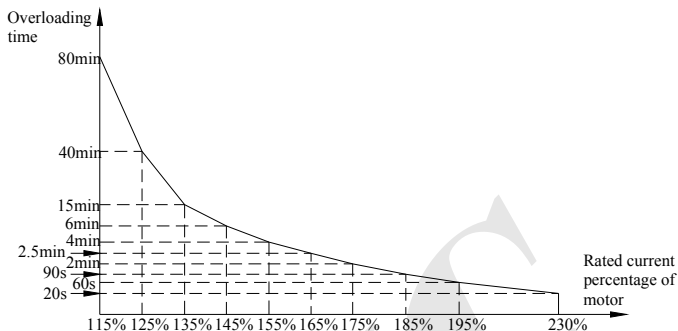

Fig.7-46 Electronic thermal relay protection

This adjustable value can base on the user's setting. In the same condition, If the AC motor is overloaded and need the fast protection, then decrease F19.04, or else increase.

F19.05	Inverter overload pre-alarm detection selection	Range: 0,1	0
--------	---	------------	---

0: Detection all the time. during the working process of inverter , it still work after detecting overload situation.

1: Enable only constant speed detection. Only the inverter work in a constant speed mode, it still works after detecting overload situation.

F19.06	Inverter overload pre-alarm detection level	Range: 20~180% (Inverter rated current)	130%
F19.07	Inverter overload pre-alarm delay time	Range: 0.0~20.0s	5.0s

If output current higher parameter F19.06, the set electrical level will go though delay time of F19.07, open collector will output enabled signal (Please refer to Fig.7-47 and parameter list F09.00~F09.04).

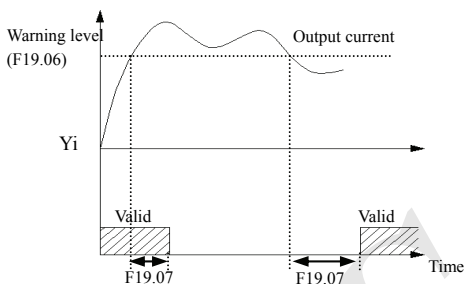

Fig.7-47 Overload alarm

F19.08	Motor underload alarm detection level	Range: 0.0~120.0% (Motor rated current)	50.0%
F19.09	Motor underload alarm detection time	Range: 0.1~60.0s	2.0s

The output current Inverter will lower than Underload alarm detection level F19.08 (Definite the value, comparing to motor rating current) , and the last time will over motor underload alarm detection level time F19.09, then Yi will output underload alarm Signal .

F19.10	Motor underload alarm detection action	Range: Units digit: 0~2 Tens digit: 0~2	00
--------	--	--	----

Units digit: detection selection.

0: No detection.

1: The operation has been detected all the time. This detection is enabled during the running process of inverter.

2: Detect in constant speed mode only. This detection is enabled during the constant speed mode only.

Tens digit: action selection.

0: When it's in alarm, continue operation. inverter will only warn when detecting motor is underload alarm

1: Alarm, Stop according to the stop mode

2: Fault, Free stop .The inverter will detect motor is in underload alarm, and it will lock PWM output, the motor will stop with free rotation.

F19.11	Input & output phase loss, short circuit detection action	Range: Units digit: 0,1 Tens digit: 0,1 Hundreds digit:0,1 Thousands digit: Reserved.	0111
--------	---	--	------

Units digit: Input phase loss

0: No detection.

1: Fault, Free stop .When inverter detect that the input is lacked one phase, alarm in input lacked, alarm, and free stop.

Tens digit: Output phase failure protection

0: No detection.

1: Fault, Free stop .When inverter detect that the output is lacked one phase, alarm in input lacked, then Free stop.

Hundreds digit: Power-on will detect Short circuit protection.

0: No detection.

1: Fault, Free stop. When inverter is power-on, the output to earth is short-circuiting. At this time, the fault of short-circuiting to earth while power on is alarmed, the inverter freely stops.

Thousands digit: Reserved.

F19.12	Overvoltage stall selection	Range: 0,1	1
--------	-----------------------------	------------	---

0: Disabled.

1: Enabled.

F19.13	Overvoltage stall protection voltage	Range: 100~150%	125%
--------	--------------------------------------	-----------------	------

During deceleration, the motor's decelerate rate may be lower than that of drive's output frequency due to the load inertia. At this time, the motor will feed the energy back to the drive, resulting in the voltage rise on the drive's DC bus. If no measures taken, the drive will trip due to over voltage.

During the deceleration, the drive detects the bus voltage and compares it with the over voltage point at stall defined by F19.13. If the bus voltage exceeds the stall over-voltage point, the output frequency of the inverter will stop decreasing. When the bus voltage become lower than the point, then run slowly, as shown in Fig. 7-48.

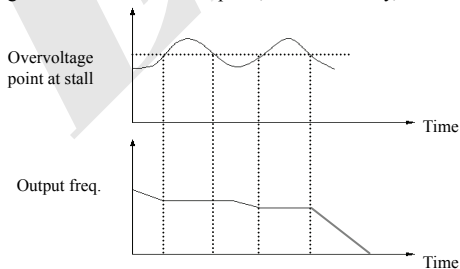

Fig. 7-48 Over-voltage at stall

F19.14	Automatic current limit level	Range: 50~230%	170%
F19.15	Frequency decline rate of automatic current limit	Range: 0.00~99.99Hz/s	10.00Hz/s
F19.16	Automatic current limit action selection	Range: 0,1	0

0: Constant speed disabled.

1: Constant speed enabled.

Auto current limiting function is used to limit the load current smaller than the value defined by F19.14 in real time. Therefore the drive will not trip due to surge over-current. This function is especially useful for the applications with big load inertia or big change of load.

F19.14 defines the threshold of auto current limiting. It is a percentage of the drive's rated current.

F19.15 defines the decrease rate of output frequency when the drive is in auto current limiting status.

If F19.15 is set too small, overload fault may occur. If it is set too big, the frequency will change too sharply and therefore, the drive may be in generating status for longtime, which may result in overvoltage protection.

Auto current limiting function is always active in Acc or Dec process. Whether the function is active in constant speed operating process is decided by F19.16.

F19.16=0 Auto current limiting function is disabled in constant speed operating process;

F19.16=1 Auto current limiting function is enabled in constant speed operating process;

In auto current limiting process, the drive's output frequency may change; therefore, it is recommended not to enable the function when the drive's output frequency is required stable.

F19.17	Rapid current-limiting coefficient	Range: 150%~250%	230%
--------	------------------------------------	------------------	------

The rapid current limit function can reduce the AC drive's over-current faults at maximum, guaranteeing uninterrupted running of the AC drive. If the AC drive is in a rapid current limit state for a long time, the AC drive may be overheated or overloaded for further protection.

The lower the setting of the F19.17, the more sensitive the rapid current limit is. When the F19.17 equals 250%, the rapid current limit function is invalid.

F19.18	Motor run section selection when instant power off	Range: 0,1	0
--------	--	------------	---

0: Disabled

1: Enabled

F19.19	Frequency droop rate when instant power off	Range: 0.00~99.99Hz/s	10.00Hz/s
F19.20	Voltage rebound estimate time when instant power off	Range: 0.00~10.00s	0.10s
F19.21	Action estimate voltage when instant power off	Range: 60~100%	80%
F19.22	Allowed the longest off time when instant power off	Range: 0.30~5.00s	2.00s

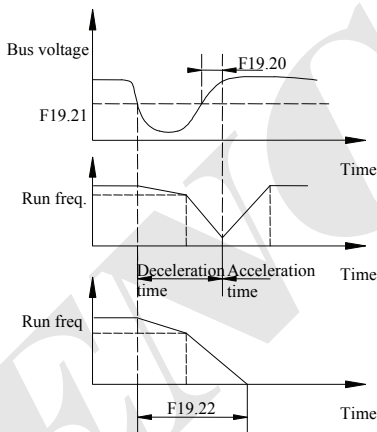

Fig 7-49 AC drive action diagram upon instantaneous power failure

This function means that in the event of an instantaneous power failure or a sudden drop in voltage, the inverter reduces the output speed and compensates the load feedback energy for the reduction of the inverter's DC bus voltage to keep the inverter running. See Fig.7-49 for the schematic diagram of instantaneous power failure.

If F19.18=1, when the power fails or the voltage suddenly falls below the value defined by F19.21 (based on the rated bus voltage), the inverter will decelerate at the frequency drop rate defined by F19.19, and when the bus voltage returns to normal. When, the inverter normally accelerates to the set frequency. The basis for judging that the bus voltage returns to normal is that the bus voltage is normal and the duration exceeds the time set by F19.20. If the instantaneous power failure time exceeds the time defined by F19.22, the inverter will freely stop due to fault.

F19.23	Terminal external device fault action selection	Range: 0~2	2
--------	---	------------	---

0: Alarm, continue operation. When inverter checked that Terminal of the external is no alarm, stop in stopping mode enabled, it will alarm, then run continue. Under this mode, the inverter will do nothing with Terminal of the external in No alarm, stop in stopping mode, so please cautiously use.

1: Alarm, Stop according to the stop mode. When Inverter detect terminal outside fault is enabled, alarm, and then press Stop in stopping mode.

2: Fault, Free stop. When inverter detect terminal external fault is enabled, alarm for external equipment fault, and free stop.

F19.24	Power on terminal protection selection	Range: 0,1	0
--------	--	------------	---

0: Disabled.

1: Enabled.

When setting power down and then restart function is enabled, this function is disabled. When the running command channel is terminal command, and when power-on and detection run the command is enabled, it will get terminal protection with faults, this function only is enabled for terminal FWD/REV function.

F19.25	Provide lost detection value	Range: 0~100%	0%
F19.26	Provide lost detection time	Range: 0.0~500.0s	0.5s

When setting PID is lower than F19.25 definition continuous (Setting the Max. as base), and the constant time is over than the time that F19.26 definition detected, then PID setting will lost, inverter will run base on F19.31 Units place set. PID loss detection show on Fig 7-50.

F19.27	Feedback lost detection value	Range: 0~100%	12%
F19.28	Feedback lost detection time	Range: 0.0~500.0s	0.5s

When the feedback value of PID is lower than F19.27 definite (Setting the input as base, and the constant time is over than the time that F19.28 definition detected, then PID setting will lost. Inverter will run base on F19.31 Tens place set. PID loss detection show on Fig.7-50.

F19.29	Deviation magnitude abnormal detection value	Range: 0~100%	50%
F19.30	Deviation magnitude abnormal detection time	Range: 0.0~500.0s	0.5s

When the Error amount of PID is higher than F19.29 definite (Based on 10V), and the constant time is over than the time that F19.30 definition detected, then PID setting will lost. Inverter will run base on F19.31 hundred's place set. PID loss detection show on Fig 7-50.

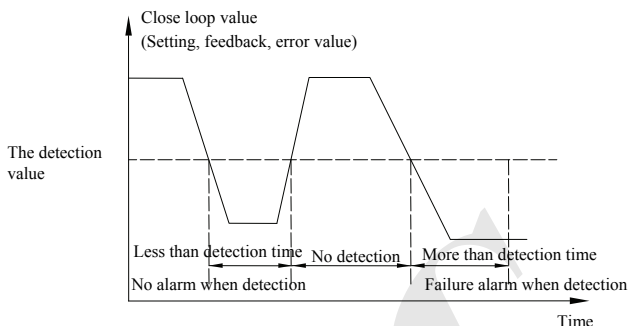

Fig. 7-50 Closed loop detection timing diagram

F19.31	Protection action selection 1	Range: Units digit: 0~3 Tens digit: 0~3 Hundreds digit: 0~3	000
--------	-------------------------------	---	-----

This parameter defines the Internal PID controls the action selection of the setting loss and the fault Error amount. When it's set as 0 or 1, inverter will have no response. And with no protection selection, users should set this parameter based on the actual applications.

Units digit: setting PID lost motion detection.

0: No detection.

1: Alarm, continue operation

2: Alarm, Stop according to the stop mode

3: Fault, Free stop.

Tens digit: PID feedback for lost motion detection.

0: No detection.

1: Alarm, continue operation.

2: Alarm, Stop according to the stop mode.

3: Fault, Free stop.

Hundreds digit: The amount of error fault for PID detection operation

0: No detection.

1: Alarm, continue operation

2: Alarm, Stop according to the stop mode

3: Fault, Free stop.

F19.32	Protection action selection 2	Range: Units digit: 0~2 Tens digit: 0~2 Hundreds digit: Reserved Thousands digit: 0,1	1200
--------	-------------------------------	--	------

This parameter definite the communication fault, E²PROM fault, Contactor fault and lack-voltage when it's in No alarm, stop in stopping mode for the action selection of inverter. When it's set as 0, during the fault situation, inverter will only alarm. And with no protection selection, users should set this parameter basing on the actual applications.

Units digit: Communication fault action, including communication replay and fault.

- 0: Alarm, continue operation
- 1: Alarm, Stop according to the stop mode
- 2: Fault, free stop.

Tens digit: E²PROM fault action selection.

- 0: Alarm, continue operation
- 1: Alarm, stop according to the stop mode
- 2: Fault, free stop.

Hundreds digit: Reserved.

Thousands digit: running lack-Voltage fault display action selection.

- 0: no detection.
- 1: Fault, free stop.

F19.33	Reserved		
F19.34	Reserved		

F19.35	Fault indication and clock during the period of recovery	Range: Units digit: 0,1 Tens digit: 0,1	00
--------	--	--	----

Units digit: During automatic reset of fault display selection.

0: Action. During automatic reset, Yi and Relay of will update display the Signal based on the internal state.

- 1: No action. During automatic reset, Yi and Relay display Signal No action.

Tens digit: Lock function selection, to realize display before power-off.

0: Disabled.
1: Enabled. When this function is enabled, if the inverter shows the fault before the last time power down, then the inverter will display the fault last time fault state, make sure that users will know about the inverter's potential faults.

F19.36	Continuous run frequency selection when alarm	Range: 0~3	0
--------	---	------------	---

This parameter defines the run frequency when users choose "Alarm, continues to run" for the inverter's failure.

- 0: Running at the current setting frequency.**
- 1: Running at the upper limiting frequency.**
- 2: Running at the lower limit frequency.**

3: Running at the fault Alternate frequency.

F19.37	Abnormal standby frequency	Range: 0.00Hz~upper limit frequency	10.00Hz
---------------	-----------------------------------	--	----------------

This parameter definite the alternative running frequency when inverter fault , user can use it along with parameterF19.36.

F19.38	Reserved		
---------------	-----------------	--	--

F19.39	Overspeed detection value	Range: 0.0~120.0% (Equals upper limit frequency)	120.0%
F19.40	Overspeed detection time	Range: 0.00~20.00s (No detection while at 0)	0.00s

Under the open-loop or the closed-loop vector mode, when it was detected that the motor rotational speed is higher than the setting value of F19.39, and after the continue time of F19.40's setting value, the inverter alarms fault of E-38 and freely stop. No detection when F19.40 equals 0, but detection is still available when F19.39 equals 0.

F19.41	Detection value of too large speed deviation	Range: 0.0~50.0% (Equals upper limit frequency)	10.0%
F19.42	Detection time of too large speed deviation	Range: 0.00~20.00s (No detection while at 0)	0.00s

Under the vector running mode, when it was detected that the difference of motor rotational speed and setting rotational speed equals the setting value of F19.41, and after the continue time of F19.42's setting value, the inverter alarms fault of E-39 and freely stop. No detection when F19.42 equals 0, but detection is still available when F19.41 equals 0.

F19.43	Overvoltage suppression coefficient	Range: 0.0~100.0%	0.0%
---------------	--	--------------------------	-------------

The bigger value of F19.43, the more obvious the suppression will be, but the load response will be slow, the parameter is available when F00.24=1 and F15.00=0.

When the load fluctuation is strong, the devices like crusher, punch, pipe file machine and the equipment with clutch will be over-voltage easily, so increasing the parameter is needed.

F19.44	Fans start temperature	Range: 0.0~100.0℃	75℃
---------------	-------------------------------	--------------------------	------------

Under the intelligent control of the fan, when inverter temperature higher than the temperature which setup in F19.44, the fans start, When inverter temperature lower than (F19.44-10)℃, it will turn off the fans.

F19.45 ~ F19.50	Reserved		
-------------------------------------	-----------------	--	--

7.21 Internal Virtual Input Output Node Parameter Group: F20

F20.00	Virtual input VDI1 function selection	Range: 0~90	0
F20.01	Virtual input VDI2 function selection	Range: 0~90	0
F20.02	Virtual input VDI3 function selection	Range: 0~90	0
F20.03	Virtual input VDI4 function selection	Range: 0~90	0
F20.04	Virtual input VDI5 function selection	Range: 0~90	0

VDI1 to VDI5 have the same functions as Xi terminals on the control board and can be used for digital input. For more details, see description of F08.18 to F08.25. The realization of the function set by internal virtual terminal must be based on the available terminal function.

F20.05	Virtual output VDO1 function selection	Range: 0~60	0
F20.06	Virtual output VDO2 function selection	Range: 0~60	0
F20.07	Virtual output VDO3 function selection	Range: 0~60	0
F20.08	Virtual output VDO4 function selection	Range: 0~60	0
F20.09	Virtual output VDO5 function selection	Range: 0~60	0

VDOx functions are similar to the Yi functions on the control board. The VDOx can be used together with VDIx to implement some simple logic control.

If VDOx function is set to non-0, the function setting and use of VDOx are the same as the output of parameter of Yi. Please refer to descriptions in group F09.

F20.10	Virtual output VDO1 open delay time	Range: 0.00~600.00s	0.00s
F20.11	Virtual output VDO2 open delay time	Range: 0.00~600.00s	0.00s
F20.12	Virtual output VDO3 open delay time	Range: 0.00~600.00s	0.00s
F20.13	Virtual output VDO4 open delay time	Range: 0.00~600.00s	0.00s
F20.14	Virtual output VDO5 open delay time	Range: 0.00~600.00s	0.00s

7 Detailed function specification

F20.15	Virtual output VDO1 close delay time	Range: 0.00~600.00s	0.00s
F20.16	Virtual output VDO2 close delay time	Range: 0.00~600.00s	0.00s
F20.17	Virtual output VDO3 close delay time	Range: 0.00~600.00s	0.00s
F20.18	Virtual output VDO4 close delay time	Range: 0.00~600.00s	0.00s
F20.19	Virtual output VDO5 close delay time	Range: 0.00~600.00s	0.00s

F20.10~ F20.19 definite the time of open up and shut down terminal VDO1~VDO5 definite is the delay time of internal level from open up to shut down.

F20.20	Virtual input VDI enable control	Range: 00~FF	00
--------	----------------------------------	--------------	----

Parameter F20.20 is to control VDI1~VDI5 is enable. F20.20(BIT0-BIT4) is according to the enable unit VDI1~VDI5,0 stands for disabled , 1 stands for enable. The relations are below:

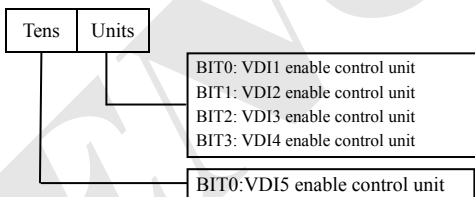

F20.21	Virtual input VDI status digital setup	Range: 00~FF	00
--------	--	--------------	----

Virtual input terminal VDI state is determined by the VDI F20.21 definite virtual input VDI state Digital and virtual output terminal VDO state, the relation between them is logical OR.

Parameter F20.21 BIT0-BIT4 is according to VDI1-VDI5 state, 0 stands for disabled state, 1 stands for enabled state.

F20.22	Virtual input; output connection	Range: 00~FF	00
--------	----------------------------------	--------------	----

Bit0: The connection of VDI1 and VDO1

0: Positive logic.

1: Negative logic.

Bit1 : The connection of VDI2 and VDO2

0: Positive logic.

1: Negative logic.

Bit2: The connection of VDI3 and VDO3

0: Positive logic.**1: Negative logic.**

Bit3: The connection of VDI4 and VDO4

0: Positive logic.**1: Negative logic.**

Bit4: The connection of VDI5 and VDO5

0: Positive logic.**1: Negative logic.**

Parameter F20.22 definite logical relation if the virtual output terminal, Bit0~Bit4 is according to logical relation setting of VDI1~VDI5 and VDO1~VDO5 , 0 stands for positive logic , 1 stands for negative logic.

**Note**

Parameter F20.21 definition VDI state, the Digital setting will not influence by F20.22.

7.22 Reserved parameter group:F21

F21.00 ~ F21.12	Reserved		
-----------------------	----------	--	--

7.23 Reserved parameter group:F22

F22.00 ~ F22.35	Reserved		
-----------------------	----------	--	--

7.24 Reserved parameter group:F23

F23.00 ~ F23.18	Reserved		
-----------------------	----------	--	--

7.25 Lifting special parameter group: F24

F24.00	Rising brake release frequency	Range: 0.0~10.00Hz	0.00Hz
F24.01	Delay of rising brake release frequency	Range: 0.01~10.00s	0.40s

7 Detailed function specification

F24.02	The brake release current value when rising(percentage of motor rated current)	Range: 0~200.0%	50.0%
F24.03	The brake release time when rising	Range: 0~10.00s	0.20s
F24.04	The brake release frequency when falling	Range: 0.60~10.00Hz	1.00Hz
F24.05	Delay of brake release frequency when falling	Range: 0.01~10.00s	1.00s
F24.06	The brake release current value when Falling	Range: 0~200.0%	20.0%
F24.07	The brake release action time when falling	Range: 0~10.00s	0.4s
F24.08	The stop brake frequency when rising	Range: 0.60~10.00Hz	1.00Hz
F24.09	The stop brake delay when rising	Range: 0~10.00s	0.40s
F24.10	The stop brake action time when rising	Range: 0~10.00s	0.10s
F24.11	The stop brake frequency when falling	Range: 0.60~10.00Hz	1.00Hz
F24.12	The stop brake delay when falling	Range: 0~10.00s	0.50s
F24.13	The stop brake action time when falling	Range: 0~10.00s	0.50s

To use the lifting brake function. Firstly, need to configure the corresponding digital output port to 52 (When the inverter output port is not used to control the brake, can skip this step),Then set F24.00 to a non-zero value, and start mode F02.00 which cannot be set to 1, and deceleration mode F02.11 needs to be set to 0. When the lifting brake function is not used, F24.00 must be set to 0.00.

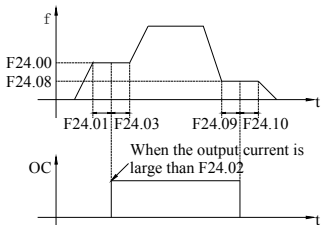

Fig.7-51 The release process when rising

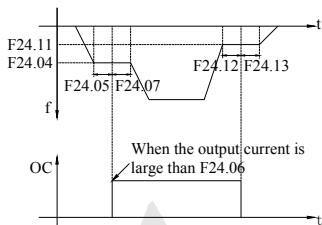

Fig.7-52 The release process when falling

The brake release process when rising: given the rising command, the inverter outputs the rising brake release frequency (F24.00), maintain this frequency for a certain time delay (F24.01), and judge that the output current reaches the rising brake release current value (F24.02), The output port will output the brake release signal. After the delay time is reached, the inverter will continue to output this frequency (F24.00) for a certain time (F24.03).

Rising brake process: when rising, a stop command will be given, the output frequency will decrease to the rising stop brake frequency according to the set deceleration ramp (F24.08), hold this frequency for a certain time delay (F24.09), the output port will output the brake After that, the inverter will continue to output this frequency (F24.08) for a certain period of time (F24.10).

Falling brake release process: Given a descending command, the inverter will output the lowering of the brake release frequency (F24.04), maintain this frequency for a certain period of time (F24.05), and judge that the output current reaches the falling brake release current value (F24.06),The output port will output the brake release signal. After the delay time is reached, the inverter will continue to output this frequency (F24.04) for a certain time (F24.07).

The brake process when falling: when falling, a stop command is given, and the output frequency drops to the falling stop brake frequency (F24.11) according to the set deceleration ramp. The frequency is maintained for a certain time (F24.12), and the output port will output the brake signal. After that, the inverter will continue to output this frequency (F24.11) for a certain period of time (F24.13).

7.26 User Definition Display Parameter Group: F25



F25.00	User function code 1	Range: F00.00~F25.xx	25.00
F25.01	User function code 2	Range: F00.00~F25.xx	25.00
F25.02	User function code 3	Range: F00.00~F25.xx	25.00

7 Detailed function specification





F25.03	User function code 4	Range: F00.00~F25.xx	25.00
F25.04	User function code 5	Range: F00.00~F25.xx	25.00
F25.05	User function code 6	Range: F00.00~F25.xx	25.00
F25.06	User function code 7	Range: F00.00~F25.xx	25.00
F25.07	User function code 8	Range: F00.00~F25.xx	25.00
F25.08	User function code 9	Range: F00.00~F25.xx	25.00
F25.09	User function code 10	Range: F00.00~F25.xx	25.00
F25.10	User function code 11	Range: F00.00~F25.xx	25.00
F25.11	User function code 12	Range: F00.00~F25.xx	25.00
F25.12	User function code 13	Range: F00.00~F25.xx	25.00
F25.13	User function code 14	Range: F00.00~F25.xx	25.00
F25.14	User function code 15	Range: F00.00~F25.xx	25.00
F25.15	User function code 16	Range: F00.00~F25.xx	25.00
F25.16	User function code 17	Range: F00.00~F25.xx	25.00
F25.17	User function code 18	Range: F00.00~F25.xx	25.00
F25.18	User function code 19	Range: F00.00~F25.xx	25.00
F25.19	User function code 20	Range: F00.00~F25.xx	25.00
F25.20	User function code 21	Range: F00.00~F25.xx	25.00
F25.21	User function code 22	Range: F00.00~F25.xx	25.00
F25.22	User function code 23	Range: F00.00~F25.xx	25.00
F25.23	User function code 24	Range: F00.00~F25.xx	25.00
F25.24	User function code 25	Range: F00.00~F25.xx	25.00
F25.25	User function code 26	Range: F00.00~F25.xx	25.00
F25.26	User function code 27	Range: F00.00~F25.xx	25.00
F25.27	User function code 28	Range: F00.00~F25.xx	25.00
F25.28	User function code 29	Range: F00.00~F25.xx	25.00
F25.29	User function code 30	Range: F00.00~F25.xx	25.00

This parameter is the User-defined parameter, user can choose the at most 30 from F0 to F24 that are reflect into F25, in order to check and alter more convenient.

Use F25.00 setting the first function code parameter that users plan to. then use F25.01 setting the second function code parameter that users plan to, so after the maximum 30 User-defined parameter that can define is finished, then setting

F00.00=3 (user list view, press . If users want to drop out user-defined parameter mode, setting F00.00≠3, then press .

For example: user plan to set three User-defined parameter :F02.01,F03.02 and F04.00 , following the steps below :

- (1) Use F25.00 to set the first function code parameter02.01, press  ;
- (2) Use F25.01 to set the second function code parameter03.02, press  ;
- (3) Use F25.02 to set the third function code parameter04.00, press  .
- (4) Set F00.00=3(user list view), press .

After the setting is finished , if users do not change F00.00 function code, when enter function code display state, the operation panel will display F00.00,F02.01,F03.02 and F04.00 only, if the user do not want to display User-defined parameter, setting F00.00 to the display expected mode.



Note

- (1) xx represent function code.
- (2) F25.xx represent no reflection.



Note

When the setting function parameter is not available into the range of ENA100 permit, setting the User-defined parameter will not make effective.

7.27 Fault Record Function Parameter Group: F26

F26.00	The last fault record	Range: 0~50	0
F26.01	The last two fault records	Range: 0~50	0
F26.02	The last three fault records	Range: 0~50	0
F26.03	The last four fault records	Range: 0~50	0

0: No fault.

1~14: E-01~E-14 failure.

15: Reserved.

16~26: E-16~E-26 failure.

27~29: Reserved.

30~32: E-30~E-32 failure.

33: Reserved.

34~36: E-30~E-32 failure.

37: Reserved.

38, 39: E-38, E-39 failure.

40: Reserved

41~43: E-41~E-43 failure.

44~50: Reserved.

F26.00~F26.03 definite the four times previous four code of faults and the two times previous fault for the voltage, current terminal and etc of inverter , users base on fault code and refer to fault function& fault handle process, then getting the results for different types of fault and reasons.

F26.04	Setup frequency at the last one fault	Range:0.00Hz~upper limit frequency	0.00Hz
F26.05	Output frequency at the last one fault	Range:0.00Hz~upper limit frequency	0.00Hz
F26.06	Output current at the last one fault	Range: 0.0~6553.5A	0.0A
F26.07	DC bus voltage at the last one fault	Range: 0.0~6553.5V	0.0V
F26.08	Module temperature at the last one fault	Range: 0~125℃	0℃
F26.09	Input terminal status at the last one fault		0
F26.10	Accumulated run time at the last one fault	Range: 0~65535min	0min
F26.11	Setup frequency at the last two fault	Range:0.00Hz~upper limit frequency	0.00Hz
F26.12	Output frequency at the last two fault	Range:0.00Hz~upper limit frequency	0.00Hz
F26.13	Output current at the last two fault	Range: 0.0~6553.5A	0.0A
F26.14	DC busbar voltage at the last two fault	Range: 0.0~6553.5V	0.0V
F26.15	Module temperature at the last two fault	Range: 0~125℃	0℃
F26.16	Input terminal status at the last two fault		0
F26.17	Accumulated run time at the last two fault	Range: 0~65535min	0min

F26.04~F26.17 record the running state of fault for the first and second time before, when Input terminal state at the fault, the terminal state is the whole terminal state after the time delay, including the standard input terminal state and expanded input terminal state .When Virtual terminal communication is set as the terminal panel point , the standard Input terminal state is determined by the actual physical input terminal and Virtual terminal communication .please refer to the details of the

Input terminal state :

Bit0:X1(Standard input terminal 1). 1: valid;0: invalid

Bit1:X2(Standard input terminal 2). 1: valid;0: invalid

Bit2:X3(Standard input terminal 3). 1: valid;0: invalid

Bit4: AI1. 1: valid; 0: invalid

Bit5: AI2. 1: valid; 0: invalid

Bit6: Reserved

Bit7: X5 (Standard input terminal 5). 1: valid; 0: invalid

Bit8: Reserved

Bit9: Reserved

Bit10: Reserved

Bit11: Reserved

Bit12: Reserved

BIT13: Reserved

7.28 Password and Manufacturer Function Parameter Group: F27



F27.00	User password	Range: 00000~65535	00000
--------	---------------	--------------------	-------

User password setting function is used for preventing unauthorized persons from checking and modifying the functional parameters.



Set F27.00 to 00000 if the user password function is unnecessary.

If user password function is necessary, input a 5-digit none-zero figure, and press  to confirm. The password is effective at once.

To change the password:

Press  and input the primary password, select F27.00 (F27.00=00000 at the moment), then input new password and press  to confirm. The password is effective at once.

To cancel the password:

Press  into the state of verification, and enter the original correct 5-digit password into the state of parameter editing, then select F27.00 (F27.00=00000 at the moment), and directly press  to confirm, the password can be canceled



Note

Please memorize the password. Seeking advice from manufacturer in case it is lost.

F27.01	Manufacturer password	Range: 00000~65535	00000
--------	-----------------------	--------------------	-------

Factory setting function, the user can't modify.

8 Troubleshooting

8.1 Failure and countermeasure

Possible failure types in ENA100 are shown in Table 8-1, the fault types including fault and alarm two kinds. Such as if inverter fault display E-XX, while the corresponding alarm is displayed in A-XX. Once the inverter failure, fault types are stored in the F26 fault recording parameter group, and if alarm, alarm status has been revealed, until the alarm source release, alarm status are not logged to the F26 parameter group. Some failure code is reserved for intelligent automatic diagnosis function which will be executed continuously in future. When failure takes place in the inverter, the user should check according to note of these table first and record failure phenomena detailedly. Please contact our after-sale service and technical support Department or agent in your local place when technical service is needed.

Table 8-1 Failure type and the countermeasure

Failure code	Failure type	Possible reason	Countermeasure
E-01	Overcurrent during accelerating process	Accelerating time is too short	Prolong accelerating time
		Improper V/F curve	Adjust V/F curve setting, adjust manual torque boost or change to automatic torque boost
		Restart rotating motor	Set speed checking restart function
		Low power source voltage	Check input power supply
		Too small power of the inverter	Choose inverter with high-power
		Output phase lose under vector control	Check whether the motor wiring is in good condition
E-02	Overcurrent during decelerating process	Decelerating time is too short	Prolong decelerating time
		Have potential energy load or big Inertia load	Increase braking power of external energy consumption braking subassembly
		Power of inverter is a bit small	Choose inverter with high-power
E-03	Overcurrent during constant speed process	Load change suddenly or have unwonted phenomena	Check or reduce saltation of the load
		Acc./Dec. time is set to too short	Prolong accelerating /decelerating
		low power source voltage	Check input power supply

		Power of inverter is a bit small	Choose inverter with high-power
E-04	Overvoltage during accelerating process	Unwanted input voltage	Check input power supply
		Acc. time is set to too short	Prolong accelerating time properly
		Restart rotating motor	Set speed checking restart function
E-05	Overvoltage during decelerating process	Decelerating time is too short	Prolong decelerating time
		Have potential energy load or big inertia load	Increase braking power of external energy consumption braking subassembly
E-06	Overvoltage during constant speed process	Unwanted input voltage	Check input power supply
		Acc/Dec time is set to too short	Prolong accelerating decelerating time properly
		Input voltage change abnormally	Assemble reactor
		Load inertia is a bit big	Use energy consumption subassembly
E-07	Inverter control power supply overvoltage	Unwanted input voltage	Check input power supply or look for service
E-08	Low-voltage when running	Input voltage is too low	Check the input voltage
E-09	Inverter overload protection	Acc time is set to too short	Prolong accelerating time
		DC injection braking is too big	Reduce DC injection braking Current, prolong braking time
		Improper V/F curve	Adjust V/F curve and torque boost
		Restart rotating motor	Set speed checking restart function
		Power source voltage is too low	Check power source voltage
		Load is too big	Choose inverter with high-power
E-10 (A-10)	Motor overload protection	Improper V/F curve	Adjust V/F curve and torque boost
		Power source voltage is too low	check power source voltage
		General motor run at low speed with big load	Can choose frequency conversion motor for long time low speed run

		Motor overload protection factor set incorrectly	to set motor overload protection factor correctly
		Motor blocked up or load change too suddenly and quickly	Check the load
E-11 (A-11)	Motor underload protection	The operating current of inverter less than underload threshold	Confirm whether the parameters F19.08, F19.09 setting are reasonable
		load divorced from motor	Checking whether the load divorced from motor
E-12	The input phase lose	The three-phase input power supply is abnormal	Check the three-phase input power line is off or poor contact
		Power supply board anomaly	Look for service from manufacturer or agent
		The control board anomaly	Look for service from manufacturer or agent
E-13	The output phase lose	Anomaly wire between motor and inverter	Check the motor wire
		When the motor runs inverter three-phase output unbalanced	Check whether the motor three-phase winding is balance
		Power supply board anomaly	Look for service from manufacturer or agent
		The control board anomaly	Look for service from manufacturer or agent
E-14	Inverting module protection	Transient over current of the inverter	Refer to countermeasure for Over current
		phase to phase short circuit or earthing short circuit of output 3 phase	wiring again
		Air-path blocked or fan damaged	To clear air-path or replace the fan
		Ambient temperature is too high	Lower ambient temperature
		Connecting wire or insert on control board loose	Check and connect the wire again
		Unwonted current wave caused by missing output phase etc.	Check wiring
		Assistant power supply damaged and drive voltage lacking	Look for service from manufacturer or agent

		Unwonted control board	Look for service from manufacturer or agent
E-16	Short circuit to ground when power on	Motor short circuit to ground	Change the cable or motor
		The power supplier of the inverter and the motor wiring are reversed	Change the cable or motor wiring
		Hall component is damaged or the hall wiring is poor	Look for service from manufacturer or agent
E-17 (A-17)	Inverter overheat	Continuous alarm on A-17 for more than 30 minutes	Cleaning or to improve the ventilation duct
		Duct blockage	Cleaning or to improve the ventilation duct
		The ambient temperature is too high	To improve the ventilation conditions, decreasing the carrier frequency
		Fan damage	Change new one
		When the fault occurs, can check F00.61 for details, when F00.61=0, it is the inverter module temperature overheating fault; when F00.61=1, it is the rectifier temperature detection fault; when F00.61=2, it is continuous Report A-17 alarm for over 30 minutes.	
E-18 (A-18)	External device failure	Sudden stop terminal for external failure closed	Open external failure terminal after external failure is settled
E-19	Current detecting circuit failure	Connecting wire or insert on control board loose	Check and connect the wire again
		Assistant power supply damaged	Look for service from manufacturer or agent
		Hall component damaged	Look for service from manufacturer or agent
		Unwonted amplifying circuit	Look for service from manufacturer or agent
		When the fault occurs, can check F00.61. When F00.61=1, it is U-phase current detection fault; when F00.61=2, it is V-phase current detection fault; when F00.61=3, it is W-phase current detection fault;	
E-20	External interference failure	The interruption protection of CPU is triggered, but none of the actual over current, overvoltage and short circuit signals have been detected	Press "STOP/RESET" button to reset or add external power supply filter from power input side

E-21	Internal interference failure	Internal disturbance serious	Power off and restart, if the failure persists, seek the manufacturer or dealer service
E-22 (A-22)	PID given loss	PID given loss threshold setting is not reasonable	To reset the relevant parameters
		External given disconnection	Check external given wiring
		The control board anomaly	Look for service from manufacturer or agent
E-23 (A-23)	PID feedback loss	PID feedback loss threshold setting is not reasonable	To reset the relevant parameters
		Feedback signal disconnection	Check external feedback signal wiring
		The control board anomaly	Look for service from manufacturer or agent
E-24 (A-24)	PID error amount abnormal	PID error abnormal detection threshold setting is not reasonable	To reset the relevant parameters
		The control board anomaly	Look for service from manufacturer or agent
E-25	Start terminal protection	Terminal command effective when power on .	Check the external input terminal state
E-26 (A-26)	Communication failure	Baud rate set improperly	Set Baud rate properly
		Serial port communication error	Press "STOP/RESET" key to reset, look for service
		Failure warning parameter set improperly	Modify F05.04, F05.05
		Upper device doesn't work	Check if upper device work and wiring is correct
E-27 ~ E-29	Reserved		
E-30 (A-30)	E ² PROM read and write wrongly	Mistake take place when read or write control parameter	Reset by pressing "STOP/RESET" Look for service from manufacturer or agent
E-31	Temperature detecting disconnection	Temperature sensor fault	Look for service from manufacturer or agent
		The temperature detection circuit anomaly	Look for service from manufacturer or agent
E-32	Self tuning failure	Parameter setting not according to the motor nameplate	Set parameter correctly according to the motor nameplate

		current anomaly when tuning	Select inverter match the motor
		Motor wiring error	Check the motor three-phase wiring
E-33 (A-33)	Reserved		
E-34	The factory fault 1	Debugging use in factory	
E-35	The factory fault 2	Debugging use in factory	
E-36 (A-36)	The bus capacitor overheating	Poor cooling environment	Improve the inverter heat dissipation environment
		The inverter capacity is too small	Select inverter match motor
		Bus capacitance cooling fan is damaged	Replace the bus capacitor cooling fan
E-38	Overspeed protection	Short acceleration time	Prolong the acceleration time
		Low inverter power	Select high-power inverter
		Overspeed detect parameter F19.39 and F19.40 is set improperly	Set the parameter properly according to the situation
E-39	Large speed deviation protection	Short Acceleration/ deceleration time	Prolong the acceleration time
		Low inverter power	Select high-power inverter
		Over velocity misalignment. Parameter F19.41 and F19.42 is set improperly	Set the parameter properly according to the situation
E-41	Analog channel disconnected	AI1 or AI2 detection of the physical quantity is not within a reasonable range, or AI1 or AI2 circuit contact bad	Control the AI1 or AI2 measurement of physical quantities reasonably, check AI1 or AI2 wiring
E-42	Water shortage	Water shortage signal detected in constant pressure water supply mode	Detect whether there is a water shortage in the water source
E-43	Model code does not match the machine	Model code setting error	Set the correct model code (F27.04)
E-44 ~ E-50	Reserved		

A-51	The main and auxiliary given frequency channel exclusiveness alarm	Parameter setting error	F01.00 and F01.03 cannot be set to the same channel (9: terminal encoder given except)
A-52	Terminal function exclusiveness alarm	Terminal function parameters setting repeatedly	Check the terminal function settings
A-53	Operation limit alarm	Limit run time	Please contact supplier
LOCH1.	Keypad lock	Keypad lock	Press  key for more than 2s to unlock the keypad.



Note

- (1) Alarm fault of E-16, E-14 the inverter must be power off for reset.
- (2) For the faults of over-current, short-circuit to ground while running, inverter can reset after 2s's delay.
- (3) When alarm fault of E-09, the reset time of inverter types over 75kw (Including 75kw) is 10s; for 55kw (including 55kw), the time is 4s.
- (4) When an over-current fault occurs (E-01, E-02, E-03), can view the F00.61 parameter for details, F00.61=1 means that the hardware detects an over-current signal, when F00.61=2, it means yes The software detects an over current signal.

8.2 Failure record lookup

This series inverter can record latest 4 failure code and inverter run parameter of the last 2 times failure, refer to these information can redound to finding out reason of the failure.

Failure information is all stored in F26 group parameter, please enter into F26 group parameter to see about information by referring to keypad operation method.

Code	Content	Code	Content
F26.00	Previous one failure record	F26.09	Input terminal state at previous failure
F26.01	Previous two failure record	F26.10	Running time at previous failure
F26.02	Previous three failure record	F26.11	Set freq. at previous 2 failure
F26.03	Previous four failure record	F26.12	Output freq. at previous 2 failure
F26.04	Set freq. at previous failure	F26.13	Output current at previous 2 failure

F26.05	Output freq. at previous failure	F26.14	DC bus volt. at previous 2 failure
F26.06	Output current at previous failure	F26.15	Module temp. at previous 2 failure
F26.07	DC bus volt. at previous failure	F26.16	Input terminal state of previous 2 failure
F26.08	Module temp. at previous failure	F26.17	Running time of previous 2 failure

8.3 Failure reset



- (1) Before reset you must find out reason of failure downright and eliminate it, otherwise may cause permanent damage to the inverter.
- (2) If can't reset or failure takes place again after resetting, should look for reason and continuous resetting will damage the inverter.
- (3) Reset should take place 5 minutes later after overload, overheat protection action.
- (4) For the fault of E-14, the reset is invalid, the motor wiring should be checked after power off, and restart the inverter.
- (5) When there is a fault of E-16 after power on, do not directly run the inverter after reset, and need to check whether the input, out wiring are reversed.

To resume normal running when failure takes place in the inverter, you can choose following any kind of operation:

- (1) After you set any terminal of X1~X5 to be inputted by external RESET, it will be reset after connected to COM.
- (2) When failure code is displayed, press  key after confirmed that it can be restoration.
- (3) Communication reset. Please refer to annex description.
- (4) Cut off power supply.

8.4 Alarm reset

When an alarm occurs, must eliminate alarm source which cause alarm, otherwise the alarm cannot be eliminated, also cannot be reset by reset button.

9 Maintenance

9.1 Routine maintenance

When you use this series you must assemble and operate it according to demand listed in this “service manual” strictly. During run state, temperature, humidity, vibration and aging parts will affect it, which may cause failure of the inverter. To avoid this, it is recommended to perform routine inspections and maintenance.

Table 9-1 Daily inspection and maintenance items

Period		Inspection item
Daily	Periodic	
√		Daily cleaning: (1) Inverter should be maintained in a clean state (2) Clean up the dust on the surface of inverter, prevent the dust into the inverter internal (especially metal dust). (3) Clean up the oil stain of cooling fan
	√	Check the air duct, and regularly clean.
	√	Check whether the screws is loose
	√	Check whether the inverter is corrode
√		Whether inverter installation environment changes
√		Whether the inverter cooling fan is working properly
√		Whether the inverter is overheating
√		When running whether voice of motor abnormal change.
√		Whether occur abnormal vibration when motor running
	√	Check wiring terminals have arc trace
	√	The main circuit insulation test

Recommend to inspect with following instrument:

Input voltage: electric voltmeter; output voltage: rectifying voltmeter; input output current: pincers ammeter.

9.2 Inspection and replacement of damageable parts

Some component parts in the inverter will be abraded or bear descending performance for long-term usage, to assure that the inverter can run stably and reliably, it is recommended to perform defending maintenance and replace corresponding parts if necessary.

(1) Cooling fan

Abnormal noise, even oscillation may take place if the fan have wearing bearing, aging blade, here replacement of the fan should be considered.

(2) Filter electrolyte capacitance

When frequent-changing load causes increasing pulsant current and aging electrolyte under high ambient temperature, the electrolyte capacitance may be damaged and here should replace it.

9.3 Repair guarantee

(1) We provide the free maintenance within warranty time if any failure or damage under normal usage, the warranty time can be seen in the warranty card, we will charge some when exceed warranty time.

(2) We will take some upkeep if one of following situations takes place within period of repair guarantee.

a. If did not use the inverter according to service manual strictly or did not use it under ambient demanded in service manual, which cause failure.

b. Failure caused by applying the inverter to non-normal function;

c. Failure caused by self-repair, refit which is not already allowed;

d. Damage caused by bad keeping, falling down from high place or other extrinsic factor after purchasing the inverter;

e. Failure caused by natural disaster or its reason such as unwonted voltage, thunderbolt, water fog, fire, salt corroding, gas corroding, earthquake and storm etc.;

f. Make bold to tear up product logo (such as: nameplate etc.); Body serial number don't accord with that in repair guarantee card.

(3) We calculate service fee based on actual cost, which is subject to contract if any.

(4) You can contact the agent and also our company directly if you have questions. After repair guarantee period, we shall also provide lifetime charged repair service for our products.



Note

Our company will also provide lifetime repair service with fee for inverter which is not within period of repair guarantee.

9.4 Storage

The user must pay attention to following points for temporary storage and long-term storage after purchasing the inverter:

(1) Avoid storing the inverter in high temperature, moist place and place of dust, metal powder and assure good ventilation.

(2) Longtime storage will cause low quality of electrolyte capacitance, so must assure that it's electrified for one time within 1 year and electrification time is not shorter than 1 hour and input voltage must be increased to rated value gradually by voltage regulator of 250w, meanwhile the inverter should be cut off from the motor.

Appendix A Modbus communication protocol

A.1 Summary

We provide general RS485 communication interface in our inverters for the user. Through this communication interface upper device (Such as HMI, PC, PLC controller and etc.) can perform centralized monitor to the inverter (Such as to set inverter parameter, control run of inverter, read work state of the inverter).

This communication protocol is interface criterion file designed for realizing above-mentioned function, please read it earnestly and program according to it so that realize long-distance and network control to the inverter.

A.2 Communication net buildup mode

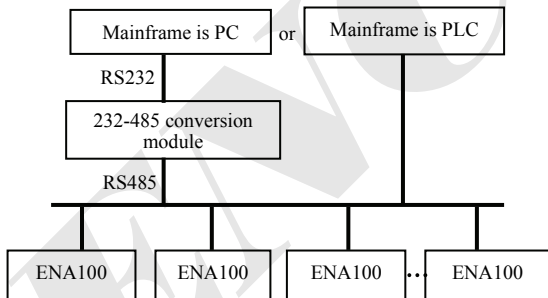

Fig.A-1 Net buildup graph

A.3 Communication mode

At present, ENA100 inverter can be used only as Slave device in RS485 net. Can realize communication between inverters through PC, PLC or HMI if it's needed. Specific communication mode is as mentioned below:

(1) PC or PLC as mainframe, inverter as Slave device, point-to-point communication between mainframe and Slave device.

(2) Slave device don't response when mainframe send out command by broadcast address.

(3) User can set local address, baud rate and data format of the inverter through Slave device keypad or serial communication mode.

(4) ENA100 provides the RS485 interface.

(5) Default mode: Asynchronous serial, semiduplex transport mode. There are RTU and ASCII two mode. Default format and transport rate: 8-N-1, 9600bps.

A.4 Transmission mode

Asynchronous serial, semiduplex transport mode. Default format and transport rate: 8-N-1, 9600bps. The detail setting parameter, please refer to the F05 group function mode.

(Remark: The parameter is valid under the Modbus communication, the other parameter comply with the original service manual)

F05.00	Protocol selection	0: Modbus protocol 1~4: Reserved 5: Free protocol 1(Revision all the parameter of ENA100 is valid) 6: Free protocol 2(Only revising part parameter of ENA100 is valid)	1	0	×
F05.01	Baud rate setting	Units digit: free protocol and Modbus Baud rate selection 0~3:Reserved 4:4800BPS 5:9600BPS 6:19200BPS 7:38400BPS 8:57600BPS 9:11520BPS	1	005	×
F05.02	Data format	Units digit: free protocol and Modbus protocol Data format 0:1-8-1 format, No checkout, RTU 1:1-8-1 format, Even Parity, RTU 2:1-8-1 format, Odd Parity, RTU 3:1-7-1 format, No checkout, ASCII 4:1-7-1 format, Even Parity, ASCII 5:1-7-1 format, Odd Parity, ASCII		00	×
F05.03	Local address	0~247, 00 is broadcast address	1	1	×

A.5 Data communication structure

A.5.1 Data frame format

Using RTU mode, messages are sent at least 3.5 character time interval pause.

The first transmitted field is device address, the character you can transfer is hexadecimal 0x00 ~ 0xFF. Network equipment continuously monitor the bus, including pauses. When the address field is received, all equipment determine whether it is sent to their own. When the last character of the packet transfer is complete, at least a 3.5 character times pause mean the end of the message. A new message can begin after this pause.

The entire message frame must be transmitted as a continuous flow. If a new message start transmitting in less than 3.5 character times after a message and then receiving device will consider it a continuation of the previous message. This will cause an error, because in the final CRC field value can not be right. RTU frame format as the table below:

Frame Header	3.5 characters time pause
Slave address	Slave address:0~247
Communication command code	03H:read slave parameter 06H:write slave parameter
Data content DATA	The contents of packet: Parameter address(16bit); Number of parameter or bytes of parameter value; Parameter value(16bit)
Data content DATA	
.....	
.....	
CRC check value low byte	16bit Unsigned check value
CRC check value high byte	
Closing Flag	3.5 characters time pause

Regarding generation method of CRC check value, please refer to Section A.9. ASCII frame format as the table below:

Frame Header	“?”(0x3A)
Slave address Hi	Slave address: Combined by 2 ASCII code
Slave address Lo	8 bit slave address 0~247
Command code Hi	Command code: 8 bit command code combined by 2 ASCII code
Command code Lo	03H: Read slave parameter 06H: Write slave parameter
Data content DATA	The contents of data packet:
Data content DATA	N pieces of 8bit data content combined by 2*N pieces of ASCII code
.....	
.....	
LRC CHK Hi	LRC check value includes 2 pieces of ASCII code
LRC CHK Lo	

Closing Flag Hi	Closing Flag Hi = CR(0x0D)
-----------------	----------------------------

A.5.2 Host read slave parameter

Command code 03H. Host can read one or more parameter (up to ten) by initiating a communication transaction .

E.g., read 2 contiguous inverter parameter values from the address 0000H of inverter whose address is 01, the contents of host command :

ADR	01H
CMD	03H
Parameters initial address high byte	00H
Parameters initial address low byte	00H
Number of parameter high byte	00H
Number of parameter low byte	02H
CRC check value low byte	C4
CRC check value high byte	0B

The contents of slave reply:

ADR	01H
CMD	03H
Parameter value bytes	04H
Address 0000H content high byte	00H
Address 0000H content low byte	00H
Address 0001H content high byte	00H
Address 0001H content low byte	03H
CRC check value low byte	BA
CRC check value high byte	F2

A.5.3 Host write slave parameter

Command code 06H. Host can write an parameter by initiating a communication transaction .

E.g.,The decimal system 5000 (1388H) written to the inverter 0101H address whose slave address is 02, host command including:

ADR	02H
CMD	06H
Parameter address high byte	01H
Parameter address low byte	01H
Parameter value high byte	13H

Parameter value low byte	88H
CRC check value low byte	D4
CRC check value high byte	93

The contents of slave reply:

ADR	02H
CMD	06H
Parameter address high byte	01H
Parameter address low byte	01H
Address 0101H content high byte	13H
Address 0101H content low byte	88H
CRC check value low byte	D4
CRC check value high byte	93

A. 6 Data communication address allocation

A.6.1 Function code F00-F26 group communication address

Inverter function parameter's MODBUS communication address addressing process follows PPnn way: PP means high byte of the address, corresponding to function parameter's group number; nn means low byte of the address, corresponding to function code parameter's group internal code. For example: F3.21 function code's communication address is 0315H, 03H is the hex form of group number 3, 15H is the hex form of group internal code 21.

F00.00~F26.17 communication address is 0000H~1A11H, F26 group fault record parameter start address is 1A00H.

A.6.2 Control command and status word communication address

Variable Name	Communication address	Reading-writing attribute	Command data or response value meaning
Run command word	1 E00H	Reading and writing	1: Reserved
			2: Jog stop command
			3: Forward JOG run
			4: Reversal JOG run
			5: Run
			6: Stop
			7: Forward run
			8: Reversal run
			9: Fault reset

			10: Reserved
Serial port value setting	1E01H	Reading and writing	F01.02 while hundreds place=0: 5000 represents 50.00Hz F01.02 while hundreds place=1: 10000 represents F01.11
Inverter status	1E02H	Reading only	BIT0: Bus voltage set BIT1: The ordinary run command effectively BIT2: JOG command effectively BIT3: Running BIT4: The current running direction is reverse BIT5: The operating instructions is reverse direction BIT6: Deceleration braking BIT7: Acceleration BIT8: Deceleration BIT9: Alarm BIT10: Fault BIT11: Current limit BIT12: Fault self recovery BIT13: Self tuning BIT14: Free stop State BIT15: Speed tracking start
Alarm code	1E03H	Reading only	0: no alarm 1 ~ 50: the current alarm code

**Note**

Modbus communication address: the given address of frequency communication is 1E01, the given address of torque communication is 1D01, and the given address of PID communication is 1D00.

A.6.3 Monitor parameter communication address

Variable name	Communication address	Read-write attribute	Command data or response value
C-00	1C00H	Reading	Monitoring parameters 1
C-01	1C01H	Reading	Monitoring parameters 2
C-02	1C02H	Reading	Monitoring parameters 3
C-03	1C03H	Reading	Monitoring parameters 4
C-04	1C04H	Reading	Monitoring parameters 5
C-05	1C05H	Reading	Monitoring parameters 6

A.6.4 Hidden parameters

Variable name	Communication address	Read-write attribute	means of command data or response value
PID Communication presetting value	1D00H	Read-write	Range: 0~1000(1000 represents 10.00V)
Torque communication presetting value	1D01H	Read-write	Range:0~2000(2000 represents 200.0% rated motor torque)
Communication AO1 given value	1D02H	Read-write	Range: 0~4000 (4000 represents 10.00V or 20.00mA)
Reserved	1D03H	Read-write	Range: 0~4000 (4000 represents 10.00V or 20.00mA)
Reserved	1D04H	Read-write	Range: 0~4000 (4000 represents 10.00V or 20.00mA)
Reserved	1D05H	Read-write	Range: 0~4000 (4000 represents 10.00V or 20.00mA)
Communication DO given value	1D06H	Read-write	Range: 0~4000 (4000 represents 10.00V or 20.00mA)
Reserved	1D07H	Read-write	Range: 0~4000 (4000 represents 10.00V or 20.00mA)
The communication output terminal given value	1D08H	Read-write	BIT0: Y1 BIT1: Y2 BIT2: Reserved BIT3: Reserved BIT4: RLY1 BIT5: Reserved BIT6: Reserved BIT7: Reserved BIT8: Reserved BIT9: Reserved BIT10: Reserved
Communication virtual input terminal given value	1D09H	Read-write	BIT0: CX1 ... BIT7: CX8
Positive torque limited frequency	1D0AH	Read-write	Range: 0~60000(60000 represents 600.00Hz)
Negative torque limited frequency	1D0BH	Read-write	Range: 0~60000(60000 represents 600.00Hz)
PID feedback voltage	1D0CH	Read-write	Range: 0~4000(4000 represents 10.00V)
Reserved	1D0DH	/	

A.7 Communication error processing

Inverter receiving data packet detection error, it finds reading&writing parameter address or parameter value invalid, so reply to the host with communication error response packet. Communication error response packet (host command code +80H) as command code, with 1 byte error code.

Format for communication error response packet as follows:

ADR	01H
CMD	83H/86H
Communication error code	01H~06H (For details, please check below table)
Low byte of CRC checksum	Obtain by calculating
High byte of CRC checksum	Obtain by calculating

Meaning for each communication error code value as follows:

Communication error code value	Communication error type	Priority
0x01	CRC checksum error	1
0x02	Command code illegal	2
0x03	Register address visited illegal	3
0x04	Value to register illegal	4
0x05	Not allow to modify parameters	5
0x06	Register number read illegal	6

A.8 Data frames examples

A.8.1 RTU Mode

1. Start #1 inverter running

Data Field	Slave Address	Order code	Register address High byte	Register address Low byte	Data High byte	Data Low byte	CRC low bit	CRC high bit
host command frames	01	06	1E	00	00	05	4F	E1
Slave respond frames	01	06	1E	00	00	05	4F	E1

2. Stop #1 inverter running

Data Field	Slave Inverter Address	Order code	Register address High byte	Register address Low byte	Data High byte	Data Low byte	CRC Low bit	CRC High bit
host command frames	01	06	1E	00	00	06	0F	E0
Slave respond frames	01	06	1E	00	00	06	0F	E0

3. Set #1 inverter given value to 50.00Hz

Data Field	Slave Inverter Address	Order code	Register address High byte	Register address Low byte	Data High byte	Data low byte	CRC low bit	CRC high bit
host command frames	01	06	1E	01	13	88	D3	74
Slave respond frames	01	06	1E	01	13	88	D3	74

4. Read #1 inverter running state

Data Field	Slave Inverter Address	Order code	Register address High byte	Register address Low byte	Data High byte	Data low byte	CRC low bit	CRC high bit
host command frames	01	03	1E	02	00	01	23	E2
Slave respond frames	01	03	(Respond value byte quantity) 02		00	01	79	84

A.8.2 ACSII Mode

Host read Slave, command code: 03

The host frame

The host frame format																
	Frame begin symbol	Slave address	Slave address	Command code	Command code	Register address	Register address	Register address	Register address	Register number	Register number	Register number	Register number	Checksum	Checksum	Ending symbol
Send byte	1	2	2	2	2	4	4	4	4	4	4	4	2	2	2	2

Remark:

- **Begin symbol:**
The lower computer judge the frame header of ASCII based on this. It is:','.
- **Slave address:**
Single inverter ID code, range:0~247.
There into, 0 is broadcast address. Broadcast address can control all the lined Slave simultaneously, and the Slave will not send back any Data to the host. That means the Slave only accept and do not send.
Modbus protocol without host address.
- **Command code:**
Reading the command of parameter or data from inverter, the value is:'0'3'.
- **Register address:**
The internal memory address of inverter function parameter is of 4 byte, which is ASCII mode transformed from Hexadecimal.
Corresponding relation between specific parameters and memory address can be seen in the later table.
- **Register number:**
The number of parameters read by a frame, it is 4 byte. It is ASCII mode transformed from Hexadecimal.
- **Checksum:**
From "slave address" to the character before checksum, the LRC checksum of the character string. Function terminal can be seen on the end of the text.
- **Ending code:** enter, line break. is:0x0D,0x0A

Response frame

Response frame format											
	Frame begin symbol	Slave address	Slave address	Command code	Command code	Data byte	Data byte	Data string value	Checksum	Checksum	Ending code
Send byte	1	2		2		2		N*2	2		2

Remark:

➤ **Begin code:**

The lower computer judge the frame of ASCII frame. This is ':'

➤ **Slave address:**

Single inverter ID code, range:0~247.

There into, address 0 is broadcast address. Broadcast address can control all the lined Slave simultaneously, and the Slave will not send back any Data to the host. That means the Slave only accept and do not send.

Modbus protocol is without host address.

➤ **Command code:**

The command of reading parameter or data from inverter, the value is:'0'3'.

➤ **Data byte:**

The number of parameters read by a frame. It is 4 byte, which is ASCII mode transformed from hexadecimal.

➤ **Data string value:**

The detail return Data, the length of Data string is the register address "Data byte", which is ASCII mode transformed from hexadecimal. Range: 4~40 byte

➤ **Checksum:**

From "slave address" to the character before checksum, the LRC checksum of the character string.

The function terminal can be seen in the later text.

➤ **Ending symbol:** enter, line break. Is 0x0D,0x0A

The followings are the example of command frame and return frame, all the Data are ASCII character.

➤ **Inquiry frame:**

: 0 1 0 3 0 0 0 1 0 0 0 1 F A \n\r

(The detail introduction of every byte)

“:”: beginning symbol

0 1: Slave address

0 3:read the command

0 0 0 1:storage address of reading parameter

0 0 0 1:the number of reading the parameter

FA: { 0 1 0 3 0 0 0 1 0 0 0 1 } for LRC checksum.

$$0xFA = 0x100 - (0x01 + 0x03 + 0x00 + 0x01 + 0x00 + 0x01)$$

➤ **Response frame:**

: 0 1 0 3 0 2 0 0 3 3 C 7 \n\r

(The detail introduction of every byte)

“:”: beginning symbol

0 1: Slave address

0 3:read the command

0 2:The byte length of return parameter Data.

0 0 3 3:return parameter, current storage value

C 7: { 0 1 0 3 0 2 0 0 3 3 } for LRC checksum.

$$0xC7 = 0x100 - (0x01 + 0x03 + 0x02 + 0x00 + 0x33)$$

The main frame writes slave address single register, command code: 06

The host frame

The host frame format																
	Frame begin symbol	Slave address	Slave address	Slave address	Command code	Register address	Register address	Register address	Register address	Data	Data	Data	Data	Checksum	checksum	Ending symbol
Send byte	1	2	2			4				4				2	2	

Remark:

➤ **Slave address:**

Single inverter ID code, range:0~247.

There into, address 00 is broadcast address.

➤ **Command code:**

Read parameter from inverter or command of Data, the value is:06

➤ **Register address:**

The storage address of inverter function parameter, is double byte.

The high byte is in the front and the low byte is in the back.

The detail relation between parameter and storage address can be seen in the later excel.

- **Data:**
The new value of revised parameter.
- **Checksum:**
From “slave address” to the character before checksum, the LRC
Check sum of the character string.

Response frame

Response frame format																
	Frame begin symbol	Slave address	Slave address	Command code	Command code	Register address	Register address	Register address	Register address	Data	Data	Data	Data	Checksum	Checksum	Ending symbol
Send byte	1	2	2	2	2	4	4	4	4	4	4	4	4	2	2	2

Remark:

- **Slave address:**
Single inverter ID code, range:0~247.
There into, address 00 is broadcast address.
- **Command code:**
Read parameter from inverter or command of Data, the value is:06
- **Register address:**
The storage address of inverter function parameter, is double byte.
The high byte is in the front and the low byte is in the back.
The detail relation between parameter and storage address can be seen in the later excel.
- **Data:**
The new value of revised parameter.
- **Checksum:**
From “slave address” to the character before checksum, the LRC
checksum of the character string.

The followings are the example of command frame and return frame, all the Data are ASCII character.

- **Inquiry frame:**
:0106010113885C\n\r
(The detail introduction of every byte)
“.”: beginning symbol
01: Slave address
06:write command

0 1 0 1:storage address of writing parameter

1 3 8 8:the value of writing parameter

5 C:{ **0 1 0 6 0 1 0 1 1 3 8 8**} for LRC checksum.

0x5C = 0x100 - (0x01 + 0x06 + 0x01 + 0x01 + 0x13 + 0x88)

➤ **Response frame:**

: 0 1 0 6 0 1 0 1 1 3 8 8 5 C \n\r

(Detail introduction of every byte)

“:”: beginning symbol

0 1: Slave address

0 6:write command

0 1 0 1:storage address of writing parameter

1 3 8 8:the value of writing parameter

5 C:{ **0 1 0 6 0 1 0 1 1 3 8 8**} for LRC checksum.

0x5C = 0x100 - (0x01 + 0x06 + 0x01 + 0x01 + 0x13 + 0x88)

(1) ASCII frame realizes transform by that 8Bit hexadecimal is divided as different 2 character of 4, and then grouped as hexadecimal of one 8Bit when reaching the destination.

(2) Frame header, add“:”, frame footer adds“\n\r” the enter line break character.

(3) The valid character in the protocol is: :, 0,1,2,3,4,5,6,7,8,9,A,B,C,D,E,F and hexadecimal 0DH, lower case ASCII letter a, b, c, d, e, f is invalid

(4) The subject data volume is the 2 times as RTU, checksum adopt LRC check.

(5) For the other information, please refer to the official standard protocol when need.



Note

A.9 CRC checkout mode

CRC checkout value calculating function written by C language is as follows:

```
unsigned int cal_crc_value (unsigned char *pval, unsigned char len)
{
    unsigned int crc_value=0xFFFF;
    unsigned int i;

    while(len--)
    {
        crc_value ^= *pval++;
        for(i=0; i<8; i++)
        {
```

```
        if(crc_value & 0x0001)
        {
            crc_value >>= 1;
            crc_value ^= 0xA001;
        }
        else
        {
            crc_value >>= 1;
        }
    }
}
return(crc_value);
}
```

Appendix B Free-port communication protocol

B.1 Summarization

We provide the customer with general RS485/RS232 communication interface in our ENA100 series frequency inverter. For the users, through the communication interface upper device (such as PC, PLC controller etc.) can perform centralized monitor to the inverter (such as setting inverter parameter, controlling run of inverter, reading work state of the inverter) and also long-distance control keypad can be connected to realize diverse operating requirement of the user.

This communication protocol is interface criterion file designed for realizing above-mentioned function, please read it earnestly and program according to it so that realize long-distance and network control to the inverter.

B.2 Protocol content and description

B.2.1 Communication net buildup mode

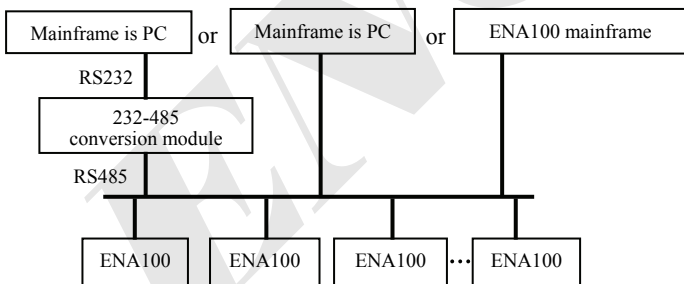

Fig.B-1 Net buildup graph

B.2.2 Communication mode

At present, ENA100 inverter can be used as not only auxiliary device but also mainframe device in RS485, If the inverter is used as auxiliary device, master device can be completed by PC, PLC or human interface, and if used as mainframe device, the main- auxiliary control of the inverter can be complement by it, Specific communication mode is as mentioned below:

- (1) PC or PLC as mainframe, inverter as auxiliary device, point-to-point

communication between mainframe and auxiliary device.

(2) Auxiliary device don't response when mainframe send out command by broadcast address.

(3) User can set local address, baud rate and data format of the inverter through auxiliary device keypad.

(4) Auxiliary device report current failure information to mainframe in the last response frame.

(5) ENA100 provides RS485 interface.

B.2.3 Transport mode

Asynchronous serial, semiduplex transport mode. Default format and transport rate: 8-N-1, 9600bps. For specific parameter setting please see description for F05 group function code.

(Remark: The definition for this parameter is only effective under free –port communication mode, and definition for other parameters are the same as original)

F05.00	Protocol selection	0:Modbus protocol 1~4:Reserved 5:Freedom protocol 1(Can modify all function parameters of ENA100) 6:freedom protocol 2 (Can only modify part of function parameter of ENA100)	1	0	×
F05.01	Baud rate configuration	Units digit: freedom protocol and Modbus baud rate selection 0~3:Reserved 4:4800BPS 5:9600BPS 6:19200BPS 7:38400BPS 8:57600BPS 9:115200BPS	1	005	×
F05.02	Data format	Units digit: freedom protocol and Modbus protocol data format 0:1-8-1 format, no checkout, RTU 1:1-8-1 format, even checkout, RTU 2:1-8-1 format, odd checkout, RTU 3:1-7-1 format, no checkout, ASCII 4:1-7-1 format, even checkout, ASCII 5:1-7-1 format, odd checkout, ASCII		00	×
F05.03	Local address	0~247, 00 is master station address	1	1	×

B.2.4 Data command frame format

Main device command frame format																		
Sending order	1	2	3	4	5	6	7	8	9	10	11	12	13	14	15	16	17	18
	Frame head	Auxiliary device address	Auxiliary device address	Main device command	Main device command	Assistant index	Assistant index	Command index	Command index	Set data	Set data	Set data	Set data	Check out sum	Check out sum	Check out sum	Check out sum	Frame end
Definition	Head	Address		Command area		Index area			Setting data area				Check out area			End		
Sending byte	1	2		2			4				4			4				1

Auxiliary device response frame format																		
Sending order	1	2	3	4	5	6	7	8	9	10	11	12	13	14	15	16	17	18
	Frame head	Auxiliary device address	Auxiliary device address	Auxiliary device response	Auxiliary device response	Failure index	Failure index	Command index	Command index	Run data	Run data	Run data	Run data	Check out sum	Check out sum	Check out sum	Check out sum	Frame end
Definition	head	address		response area		Index area			Run data area				Check out area			end		

Sending byte	1	2	2	4	4	4	1
--------------	---	---	---	---	---	---	---

Fig.B-2 Command/Response frame format

Remark:

(1) “Setting data area” and “run data area” may not be existent in some command/data frame format, So in protocol command list it’s marked with “nothing”.

(2) In protocol effective character set is: ~, 1, 2, 3, 4, 5, 6, 7, 8, 9, A, B, C, D, E, F and hex data 0DH, ASCII lowercase a, b, c, d, e, f are invalid.

(3) Effective command frame length is 14 or 18 byte.

B.2.5 Explanation and description for format

(1) Frame head

It’s character“~” (namely hex 7E), single byte.

(2) Auxiliary device address

Data meanings: local address of auxiliary device, double byte. ASCII format. Inverter factory default is 01.

(3) Mainframe command/auxiliary device respond

Data meanings: mainframe send out command and auxiliary device respond to the command. Double byte, ASCII format.

Response code function classification:

Species 1>: Command code=“10”, mainframe ask auxiliary device to report current preparation state and control situation.

Table B-1 Command code meanings for response frame response area

Response code ASCII	Meanings		
	Preparation state of auxiliary device	Control from mainframe is allowed	To set frequency is allowed
10	Haven't get ready	No meaning	
11	Get ready	Allow	Allow
12	Get ready	Allow	Allow
13	Get ready	Don't allow	Don't allow
14	Get ready	Don't allow	Don't allow
20	Frame error		

Species 2>: Command code=“11”~“15”, 5 kinds of function command which mainframe send to auxiliary device, For detail please see protocol command list.

Table B-2 Response code meanings for response frame command index area

Response code ASCII	Meanings of response code	Description
00	Auxiliary device communication and control is normal; function code modification is effective; password is correct.	
20	(1) Frame checkout error; (2)“Command area” data overrun; (3)“Index area” data overrun; (4) Frame length error/non ASCII byte exist in area except frame head, frame end.	When this response code is reported, data of “command area”, “index area” and “running data area” are not reported.
30	(1) Control to auxiliary device is Ineffective; (2) Ineffective function code parameter Modification; (3)“Setting/running data” area data overrun. (4) Password error.	Whether report this response code relate to current set state of auxiliary device. When report data of area”, “index area” and “run data area” are reported according to protocol requirement.

(4) Auxiliary index/command index/failure index

Data meanings: include auxiliary index byte and command index byte.

For mainframe, auxiliary index, command index are used for cooperating mainframe command in realizing specific function.

For auxiliary device, auxiliary index, command index are used for reporting failure state code, command index are reported without modification

Data type: hex, 4 byte, ASCII format.

Command index occupy 2 low byte, data range: “00”~“FF”.

Auxiliary index occupy 2 high byte, data range: “00”~“FF”.

Auxiliary device failure state occupy “auxiliary index” byte, see table B-3.

Table B-3 Free-port1 failure type description

Failure code (decimal)	Description	Failure code (decimal)	Description
1	Overcurrent during accelerating process	19	Current detecting circuit failure
2	Overcurrent during decelerating process	20	External interference failure
3	Overcurrent during constant speed process	21	Internal interference failure
4	Overvoltage during accelerating process	22	PID provision loss
5	Overvoltage during decelerating process	23	PID feedback loss

Appendix B Free-port communication protocol

6	Overvoltage during constant speed process	24	PID error amount exception
7	Overvoltage while halting	25	Startup terminal protection
8	Under voltage during running process	26	RS485 communication failure
9	Inverter overload protection	27	Reserved
10	Motor overload protection	28	Reserved
11	Motor underload protection	29	Reserved
12	Input phase missing	30	E ² PROM read and write wrongly
13	Output phase missing	31	Temperature detection breakage
14	Inverting module protection	32	Self-tuning failure
15	Reserved	33	Reserved
16	Short circuit to earth during electrifying process	34	Interior failure 1
17	Inverter over heating		
18	External device failure		

Free-port 2 Failure type description

Failure code (decimal)	Description	Failure code (decimal)	Description
1	Overcurrent during accelerating process	13	Inverting module protection
2	Overcurrent during decelerating process	14	External device failure
3	Overcurrent during constant speed process	15	Current detecting circuit failure
4	Overvoltage during accelerating process	16	RS485 communication failure
5	Overvoltage during decelerating process	17	Reserved
6	Overvoltage during constant speed process	18	Reserved
7	Control power supply overvoltage	19	Under voltage
8	Inverter overload	20	System interference
9	Motor overload	21	Reserved
10	Inverter over heating	22	Reserved

11	Reserved	23	E ² PROM read and write wrongly
12	Reserved		

(5) Checkout sum

Data meanings: frame checkout, 4 byte, ASCII.

Calculation method: accumulative sum of ASCII code value of all byte from “auxiliary device address ”to“ run data”.

(6) Frame end

Hex 0D, single byte.

B.2.6 Protocol command list

Frame 7E and frame end 0D, address, checkout sum, ASCII character format are omitted in following description.

Table B-4 Free-port 1 protocol command table

Name	Mainframe order	Decimal	Auxiliary index Hex	Order index Hex	Run data setting range Hex	Mainframe sending example, such as PC control operation of inverter (C language cluster format, auxiliary device is set to 01)	Run data precision	Description
Look up auxiliary motor state	10	00	00	no	~010A00000192\r	1		
Read parameter of auxiliary motor	Main setting frequency	11	00	00	no	~010A00000192\r	1	
	Auxiliary setting frequency	11	00	01	no	~010B00010194\r	0.01Hz	
	Setting frequency	11	00	02	no	~010B00020195\r	0.01Hz	
	Output frequency	11	00	03	no	~010B00030196\r	0.01Hz	
	Output current	11	00	04	no	~010B00040197\r	0.1A	
	Output voltage	11	00	05	no	~010B00050198\r	1V	
	DC bus-bar voltage	11	00	06	no	~010B00060199\r	0.1V	
	Load motor revolving speed	11	00	07	no	~010B0007019A\r	1RPM	
	Load motor linear speed	11	00	08	no	~010B0008019B\r	no	

Appendix B Free-port communication protocol

Inverter temperature	11	00	09	no	~010B0009019C\r	1°C	
Runtime	11	00	0A	no	~010B000A01A4\r	0.1min	
Current accumulative runtime	11	00	0B	no	~010B000B01A5\r	1h	
Current accumulative power-on time	11	00	0C	no	~010B000C01A6\r	1h	
Inverter state	11	00	0D	no	~010B000D01A7\r	no	
Input terminal state	11	00	0E	no	~010B000E01A8\r	no	
Output terminal state	11	00	0F	no	~010B000F01A9\r	no	
Expand output terminal state	11	00	10	no	~010B00100194\r	no	
Expanding input terminal state	11	00	11	no	~010B00110195\r	no	
Communicational virtual input terminal state	11	00	12	no	~010B00120196\r	no	
Internal virtual input node state	11	00	13	no	~010B00130197\r	no	
Analog input AI1	11	00	14	no	~010B00140198\r	no	
Analog input AI2	11	00	15	no	~010B00150199\r	no	
Expanding analog input EAI1	11	00	16	no	~010B0016019A\r	no	
Expanding analog input EAI2	11	00	17	no	~010B0017019B\r	no	
Analog AO1 output	11	00	18	no	~010B0018019C\r	no	
Analog AO2 output	11	00	19	no	~010B0019019D\r	no	
Expanding analog EAO1 output	11	00	1A	no	~010B001A01A5\r	no	
Expanding analog EAO2 output	11	00	1B	no	~010B001B01A6\r	no	
External pulse input frequency	11	00	1C	no	~010B001C01A7\r	1Hz	
Reserved							
Process PID provision	11	00	1E	no	~010B001E01A9\r	0.01V	
Process PID feedback	11	00	1F	no	~010B001F02AA\r	0.01V	

Appendix B Free-port communication protocol

Process PID error	11	00	20	no	~010B00200195\r	0.01V	
Process PID output	11	00	21	no	~010B00210196\r	0.01Hz	
Simple PLC current segments	11	00	22	no	~010B00220197\r	no	
External multi-section speed current segments	11	00	23	no	~010B00230198\r	no	
Provision pressure for constant pressure water	11	00	24	no	~010B00240199\r	0.001 Mpa	
Feedback pressure for constant pressure water	11	00	25	no	~010B0025019A\r	0.001 Mpa	
Relay state for constant pressure water	11	00	26	no	~010B0026019B\r	no	
Current length	11	00	27	no	~010B0027019C\r	no	
Accumulative length	11	00	28	no	~010B0028019D\r	no	
Current internal count	11	00	29	no	~010B0029019E\r	no	
Current internal time	11	00	2A	no	~010B002A01A6\r	no	
Setting channel for run command	11	00	2B	no	~010B002B01A7\r	no	
Main frequency provision channel	11	00	2C	no	~010B002C01A8\r	no	
Auxiliary frequency provision channel	11	00	2D	no	~010B002D01A9\r	no	
Inverter rated current	11	00	2E	no	~010B002E01AA\r	0.1A	
Inverter rated voltage	11	00	2F	no	~010B002F01AB\r	1V	
Inverter rated power	11	00	30	no	~010B00300196\r	0.1KW	
Reserved							
Reserved							
Frequency after acceleration and deceleration	11	00	33	no	~010B00330199\r	0.01Hz	

Appendix B Free-port communication protocol

	Motor rotor frequency	11	00	34	no	~010B0034019A\r	0.01Hz	
	Current provision torque	11	00	35	no	~010B0035019B\r	0.1%	
	Current output torque	11	00	36	no	~010B0036019C\r	0.1%	
	Current torque current	11	00	37	no	~010B0037019D\r	0.1A	
	Current flux current	11	00	38	no	~010B0038019E\r	0.1A	
Run control and adjusting function	Auxiliary device run command	12	00	00	no	~010C00000194\r	no	
	Set current run frequency provision of auxiliary device	12	00	01	0Hz~high limit freq	~010C00010FA0027C\r	0.01Hz	Set freq. =40.00Hz
	Auxiliary device run with run frequency provision	12	00	02	0Hz~high limit freq	~010C00020FA0027D\r	0.01Hz	Auxiliary device run Set freq. =40.00Hz
	Auxiliary device forward run	12	00	03	no	~010C00030197\r	no	
	Auxiliary device reverse run	12	00	04	no	~010C00040198\r	no	
	Auxiliary device forward run with run frequency provision	12	00	05	0Hz~high limit freq	~010C00050FA00280\r	0.01Hz	Forward run boot-strap Set freq. =40.00Hz
	Auxiliary device reverse run with run frequency provision	12	00	06	0Hz~high limit freq	~010C00060FA00281\r	0.01Hz	Reverse run boot-strap Set freq. =40.00Hz
	Auxiliary device stop	12	00	07	no	~010C0007019B\r	no	
	Auxiliary device jog run	12	00	08	no	~010C0008019C\r	no	
	Auxiliary device forward jog run	12	00	09	no	~010C0009019D\r	no	
	Auxiliary device reverse jog run	12	00	0A	no	~010C000A01A5\r	no	
Auxiliary device stop run	12	00	0B	no	~010C000B01A6\r	no		

	Auxiliary device failure restoration	12	00	0C	no	~010C000C01A7r	no	
Software version query order	Query auxiliary device software version	15	00	00	no	~010F00000197r	1	

Free-Port 2 Protocol command table

Name	Mainframe order decimal	Auxiliary index hex	Order index Hex	Run data setting range hex	Mainframe sending example, such as PC control operation of inverter (C language cluster format , auxiliary device is set to 01)	Run data precision	Description
look up auxiliary motor state	10	00	00	no	~010A00000192r	1	
Run control and adjusting function	Auxiliary device run command	12	00	00	no	~010C00000194r	no
	Set current run freq. of auxiliary device	12	00	01	0Hz~ high limit freq	~010C00010FA0027Cr	0.01Hz
	Auxiliary device run with run frequency provision	12	00	02	0Hz~ high limit freq	~010C00020FA0027Dr	0.01Hz
	Auxiliary device forward run	12	00	03	no	~010C00030197r	no
	Auxiliary device reverse run	12	00	04	no	~010C00040198r	no
	Auxiliary device forward run with run frequency provision	12	00	05	0Hz~ high limit freq	~010C00050FA00280r	0.01Hz

Appendix B Free-port communication protocol

	Auxiliary device reverse run with run frequency provision	12	00	06	0Hz~ high limit freq	~010C00060FA00281r	0.01Hz	
	Auxiliary device stop	12	00	07	no	~010C0007019B'r	no	
	Auxiliary device jog run	12	00	08	no	~010C0008019C'r	no	
	Auxiliary device forward jog run	12	00	09	no	~010C0009019D'r	no	
	Auxiliary device reverse jog run	12	00	0A	no	~010C000A01A5'r	no	
	Auxiliary device stop run	12	00	0B	no	~010C000B01A6'r	no	
	Auxiliary device failure restoration	12	00	0C	no	~010C000C01A7'r	no	
Software version query order	Query auxiliary device software version	15	00	00	no	~010F00000197'r	1	

Table B-5 Read auxiliary device function code parameter

Function definition	Read auxiliary device function code parameter: all function code parameter except user password and manufacturer password except user password and manufacturer password						
Meanings	Frame head	Address	Order	Order index	Run data	Checkout sum	Frame end
Mainframe order	7EH	ADDR	13	See remark	4	BCC	0DH
Byte quantity	1	2	2	4	0	4	1
Auxiliary device respond	7EH	ADDR	06	See remark	Function code parameter	BCC	0DH
Byte quantity	1	2	2	4	4	4	1
Remark	Command index=combination of function code group number and hex code of function code number. For instance: If want to read parameter of F0.05 function code, order index=0005; If want to read parameter of F2.11 function code, order index =020B; If want to read parameter of F2.15 function code, order index =020F; If want to read parameter of F2.13 function code, order index =020D;						

Function code group No	Corresponding relation between decimal and hex value of function code group No.					
	Decimal	Hex	Function code group No	Decimal	Hex	
F00	0	00H	F0E	14	0EH	
F01	1	01H	F0F	15	0FH	
F02	2	02H	F10	16	10H	
F03	3	03H	F11	17	11H	
F04	4	04H	F12	18	12H	
F05	5	05H	F13	19	13H	
F06	6	06H	F14	20	14H	
F07	7	07H	F15	21	15H	
F08	8	08H	F16	22	16H	
F09	9	09H	F17	23	17H	
F0A	10	0AH	F18	24	18H	
F0B	11	0BH	F19	25	19H	
F0C	12	0CH	F1A	26	1AH	
F0D	13	0DH	F1B	27	1BH	
Virtual data	0~FFFF (namely 0~65535)					

Please input correct “user password” before you set user function code parameter.

Table B-6 Set auxiliary device function code parameter

Function definition	Set auxiliary device function code parameter: all function code parameter except user password and manufacturer password						
Meanings	Frame head	Address	Order	Order index	Run data	Checkout sum	Frame end
Mainframe order	7EH	ADDR	14	See remark	4	BCC	0DH
Byte quantity	1	2	2	4	4	4	1
Auxiliary device respond	7EH	ADDR	06	See remark	Function code parameter	BCC	0DH
Byte quantity	1	2	2	4	4	4	1

Appendix B Free-port communication protocol

Remark	Command index=combination of function code group number and hex code of function code number. For instance: If want to read parameter of F00.05 function code, order index=0005; If want to read parameter of F02.11 function code, order index =020B; If want to read parameter of F02.15 function code, order index =020F; If want to read parameter of F02.13 function code, order index =020D;					
	Corresponding relation between decimal and hex value of function code group No.					
	Function code group No	Decimal	Hex	Function code group No	Decimal	Hex
	F00	0	00H	F0E	14	0EH
	F01	1	01H	F0F	15	0FH
	F02	2	02H	F10	16	10H
	F03	3	03H	F11	17	11H
	F04	4	04H	F12	18	12H
	F05	5	05H	F13	19	13H
	F06	6	06H	F14	20	14H
	F07	7	07H	F15	21	15H
	F08	8	08H	F16	22	16H
	F09	9	09H	F17	23	17H
	F0A	10	0AH	F18	24	18H
	F0B	11	0BH	F19	25	19H
F0C	12	0CH	F1A	26	1AH	
F0D	13	0DH	F1B	27	1BH	
Virtual data	0~FFFF(namely 0~65535)					

Appendix C Keyboard

C.1 Keyboard selection:

NO.	Type	Details	Remark
1	EN-LED11-D	External LED single display digital potentiometer keyboard (with parameter copy function)	Optional
2	Accessories-EN A100 components	The external cited accessories of local keyboard and 2 meters keyboard cable	It must be used with ENA100 components together when the local keyboard needs to be used as the external cited keyboard

At present, the external keyboard available for customers to choose from our company is EN-LED11-D, which can realize remote control by connecting the external keyboard interface on the control board. And the local keyboard and the external keyboard can work at the same time, it is valid after being controlled. The last operation is effective in the control.



Note

- (1) EN-LED11-D keyboard with parameter copy function. The local keyboard has no parameter copy function.
- (2) When using the parameter copy function, it can be operated by F00.27 parameter.
- (3) External keyboard and local keyboard can be used at the same time, and the last operation is effective.

C.2 LED double-display digital potentiometer keyboard

LED single display digital potentiometer external keyboard model: EN-LED11-D.

C.2.1 Keyboard Layout

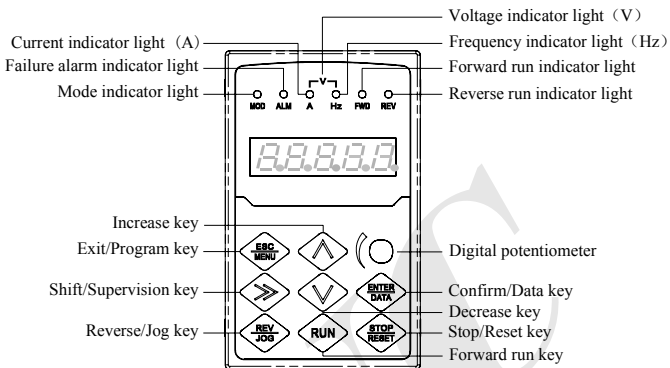

Fig.C-1 EN-LED11-D keyboard layout diagram

C.2.2 Keyboard function, LED digital tube and indicator light description

The LED single-display keyboard is composed of a five-digit digital tube display, 8 buttons, 1 digital potentiometer and 6 indicators.

The function definition of the 8 buttons on the remaining operation keyboard and indicator description, please refer to the keyboard function description in Chapter 5.



Note

(1) EN-LED11-D operation keyboard and the standard local keyboard have different key positions, please pay attention to the key position when using this kind of keyboard.

(2) EN-LED11-D keyboard is different from the standard keyboard unlocking method, the keyboard unlocking method is  key for more than 5 seconds to unlock the keyboard.

C.3 External keyboard dimensions and keyboard mounting box dimensions (Unit: mm)

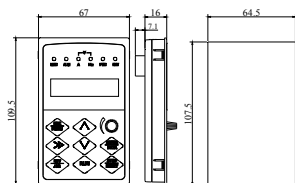

Fig.C-2 Keyboard outline dimensions and opening dimensions

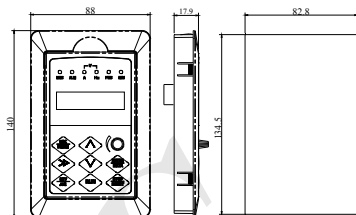

Fig. C-3 Outline and hole size of keyboard installation box

C.4 Communication components

For the operational keypad EN-LED10 and EN-LED11-D, The maximum electrical connection distance between the this keypad and the drive is 2 meters.

Following function can be realized by remote keyboard:

(1) Can control run, stop, jog, failure reset, change setting frequency, modify function parameter and run direction of auxiliary device.

(2) Can identify the type of auxiliary device. Can monitor the running frequency, setting frequency, output voltage, output current, analog closed loop feedback, analog closed loop setting and exterior counting value of auxiliary device.

C.5 The using items for the external citation of local keyboard

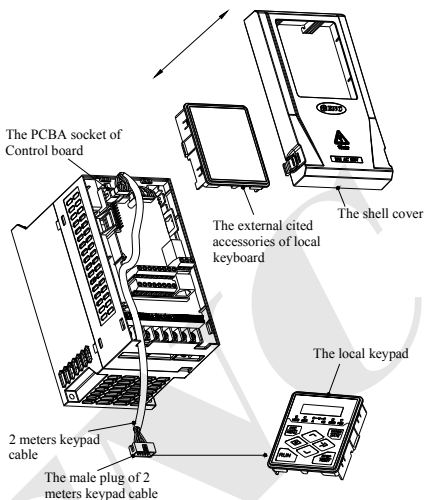

Fig.C-4 The external cited installation diagram of local keypad

Remove the shell cover and the external cited accessories of local keyboard, insert the female plug of the 2 meters keyboard cable into the upper PCBA socket of the control board, and insert the male plug into the upper PCBA socket of the keyboard, finally install the external cited accessories of local keyboard, the shell cover and the local keypad. The wiring is shown in Fig.C-4.



Note

- (1) For single-phase Drive of 0.7KW and below power, three-phase drive of 1.5KW and below power, the cable must be led out from the top of the control board.
- (2) For single-phase Drive of 1.5KW and 2.2KW, three-phase drive of 1.5KW and above power, the cable must be led out from the internal left side of the drive.

Appendix D Application Macros

D.1 Industry Application Macro Introduction

The following industry applications have been configured with functional parameters according to the habits of some customers. As long as wiring according to the provided wiring diagram and select the corresponding application macro, Then it can be easily used and reducing the workload of parameter setting.

Function code	Function code name	Function code parameter description	Unit	Factory default	Attributes
F09.49	Application macro selection	0: Universal model 1: Application of air compressor 2: Application of Extruder 3: Water pump application 4: Fan application	-	0	○

D.2 Applicable occasions of application Macros

Application Macros	Applicable occasions
Universal model	General-purpose inverter with keyboard control operation. For the terminal factory configuration, see Chapter 3 Standard Wiring Diagram of Control Circuit.
Air compressor application	The frequency converter is used as a speed regulating actuator, and the air compressor control logic is completed by the controller. 0~20mA current signal is used as frequency reference, and factory parameters are configured.
Extruder application	Analog given frequency, terminal control start and stop. Can be used for host and feed motor control
Water pump application	Constant pressure water supply applications that include sleep and wake functions to control variable frequency pumps and sleep pumps. Set target pressure digitally, 0~20mA pressure transmitter as pressure feedback, configure factory parameters
Fan application	Including Light load applications of manual / automatic switching, speed tracking start, instantaneous stop and stop function. When X2 terminal is valid, switch to manual state

D.3 Wiring diagram and parameter table for application macro

D.3.1 Wiring diagram corresponding to air compressor application macro

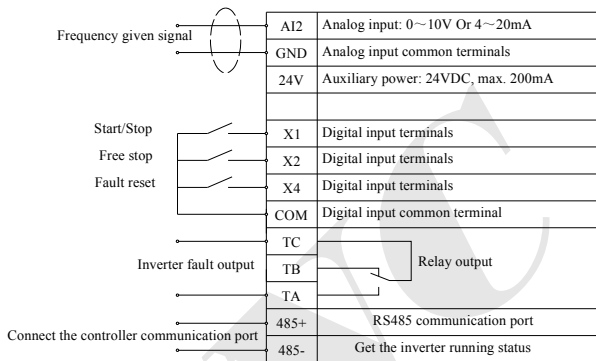

Parameter table corresponding to air compressor application macro

F09.49=1: Air compressor application. After restoring factory values, the parameters are shown in the following table:

Function code	Function code name	Function code parameter description	Unit	Factory default
F00.24	Motor control mode	0: V/F control (Torque control is not supported)	1	0
F01.15	Run command channel selection	0: Keyboard operation control	1	0
F01.00	Main frequency input channel selection	2: AI2 simulation setting	1	2
F01.17	Acceleration time 1	1~60000 (Acceleration time refers to the time required to accelerate from zero frequency to the upper limit frequency)	1	25.0
F01.18	Deceleration time 1	1~60000 (Deceleration time refers to the time required to decelerate from the upper limit frequency to zero frequency)	1	30.0
F01.11	Upper frequency	Lower limit frequency ~ 600.00Hz	0.01Hz	50.00Hz
F01.12	Lower limit frequency	0.00Hz ~ upper limit frequency	0.01Hz	30.00Hz
F01.13	Lower limit frequency operation mode	0: Run at the lower limit frequency	1	0
F01.16	Setting of running	Units digit: Keyboard command forward	1	0X1010

	direction	and reverse setting (Only valid for jog) 0: Forward 1: Reverse Tens Digit: Forward and reverse prohibition (Applicable to all command channels, excluding jog) 0: Both Forward or Reverse are permitted 1: Reverse running is prohibited (When reverse running is applied, the machine will be stopped according to the stop mode) 2: Prohibition of forward running (When forward running is applied, the machine will stop according to the stop mode). Hundreds digit: Running direction choose reverse (Only valid for keyboard and communication channel) 0: Invalid 1: Valid Thousands digit: Terminal multi-step speed Acceleration/deceleration time control 0: Corresponds to acceleration and deceleration 1~15 1: Determined by F01.17, F01.18		
F08.18	Function selection of input terminal X1	1: Forward running FWD terminal	1	1
F08.19	Function selection of input terminal X2	25: Free stop input	1	25
F06.00	Given curve selection	Units digit: A11 curve selection 0: Curve 1 1: Curve 2 2: Curve 3 Tens digit: A12 curve selection: same as units digit Hundreds digit: high-speed pulse curve selection: same as units digit Thousands digit: Pulse width given curve selection: same as units digit	1	0x0010
F06.07	Curve 2 minimum given	0.0% ~ given the inflection point of curve 2	0.1%	21.0%
F06.08	Curve 2 minimum given corresponding physical quantity	0.0~100.0%	0.1%	0.0%
F06.09	Curve 2 inflection point given	Minimum setting of curve 2 ~ maximum setting of curve 2	0.1%	21.0%

Appendix D Application Macros

F06.10	The inflection point of curve 2 gives the corresponding physical quantity	0.0~100.0%	0.1%	0%
F06.11	Curve 2 max given	Curve 2 inflection point setting ~ 100.0%	0.1%	99.0%
F06.12	Maximum physical quantity corresponding to curve 2	0.0~100.0%	0.1%	100.0%
F09.00	Open collector output terminal Y1 output setting	1: Inverter running (RUN)	1	1
F09.04	RLY1 output setting	22: Inverter fault	1	22
F02.00	Start operation mode	0: Start from start frequency	1	0
F02.11	Stop mode	0~2	1	0
F03.00	V / F curve setting	0: Constant torque curve	1	0
F19.04	Motor overload protection factor	10.0~2000.0%	0.1%	105.0

D.3.2 Wiring diagram of extruder application macro

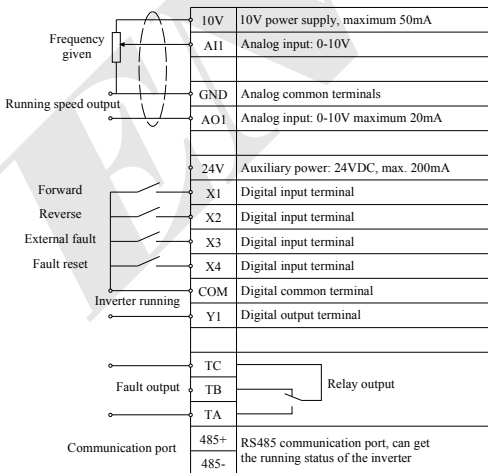

Parameter table of extruder application macro.

F09.49 = 2: Extruder application. After restoring factory values, the parameters are shown in the following table:

Function code	Function code name	Function code parameter description	Unit	Factory default
F01.15	Run command channel selection	1: Terminal running command control	1	1
F01.00	Main frequency input channel selection	1: All analog setting	1	1
F01.17	Acceleration time 1	1~ 60000 (Acceleration time refers to the time required to accelerate from zero frequency to the upper limit frequency)	1	25.0
F01.18	Deceleration time 1	1 ~ 60000 (Deceleration time refers to the time required to decelerate from the upper limit frequency to zero frequency)	1	30.0
F01.11	Upper limit frequency	Lower limit frequency ~ 600.00Hz	0.01Hz	50.00Hz
F01.12	Lower limit frequency	0.00Hz ~ upper limit frequency	0.01Hz	0.00Hz
F08.18	Function selection of input terminal X1	1: Forward running FWD terminal	1	1
F08.19	Function selection of input terminal X2	2: Reverse operation REV terminal	1	2
F08.20	Input terminal X3 function selection	22: External device fault input	1	22
F09.00	Open collector output terminal Y1 output setting	1: Inverter running (RUN)	1	1
F09.04	RLY1 output setting	22: Inverter fault	1	22
F02.00	Start operation mode	0: Start from start frequency	1	0
F02.11	Stop mode	0: Deceleration stop	1	0
F03.00	V / F curve setting	4: User-set V/F curve (Determined by F03.04 ~ F03.11 function code)	1	4
F03.04	V / F frequency value 0	0.00 ~ V / F frequency value 1	0.01Hz	0.50Hz
F03.05	V / F voltage value 0	0.00 ~ V / F voltage value 1	0.01%	2.00%
F03.06	V / F frequency value 1	V / F frequency value 0 ~ V / F frequency value 2	0.01Hz	2.00Hz
F03.07	V / F voltage value 1	V / F voltage value 0 ~ V / F voltage value 2	0.01%	5.50%
F03.08	V / F frequency value 2	V / F frequency value 1 ~ V / F frequency value 3	0.01Hz	5.00Hz
F03.09	V / F voltage value 2	V / F voltage value 1 ~ V / F voltage value 3	0.01%	10.00%
F03.10	V / F frequency value 3	V / F frequency value 2 ~ upper limit frequency	0.01Hz	40.00Hz

F03.11	V / F voltage value 3	V / F voltage value 2 ~ 100.00% (rated motor voltage)	0.01%	80.00%
F03.02	Torque boost	0.0~12.0%	0.1%	0.0%

D.3.3 Wiring diagram of pump application macro

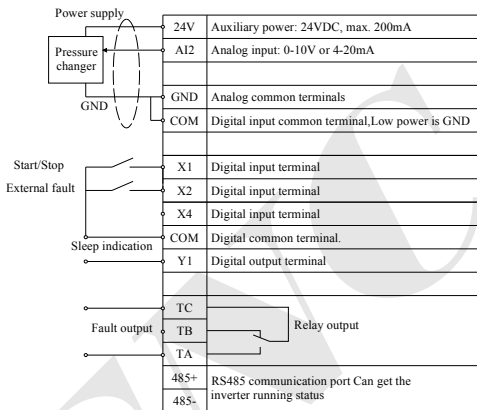

Parameter table corresponding to water pump application macro

F09.49=3; For pump applications, The parameters are shown in the following table after restore the factory value.

Functions: Process PID, instantaneous stop, common failure retry, sleep wake function Water pressure conversion relationship:

$$1\text{bar} \approx 0.1\text{Mpa} = 100\text{kPa} \approx 1\text{kg/cm}^2$$

Function code	Function code name	Function code parameter description	Unit	Factory default
F01.15	Run command channel selection	0: Operation keyboard operation control	1	0
F11.00	Closed-loop operation control selection	1: PID closed-loop operation control is effective	1	1
F12.00	Constant pressure water supply mode selection	1: Single pump water supply mode	1	1
F01.17	Acceleration time 1	1 ~ 60000 (acceleration time refers to the time required to accelerate from zero frequency to the upper limit frequency)	1	25

F01.18	Deceleration time 1	1~60000 (Deceleration time refers to the time required to decelerate from the upper limit frequency to zero frequency)	1	30
F01.11	Upper limit frequency	Lower limit frequency ~ 600.00Hz	0.01Hz	50.00Hz
F11.15	PID adjustment upper limit frequency	0.00Hz~upper limit frequency	0.01Hz	50.00Hz
F01.13	Lower limit frequency operation mode	3: Sleep, PWM blocking during sleep	1	3
F01.16	Setting of running direction	Units digit: Keyboard command forward and reverse setting (Only valid for jog) 0: Forward 1: Reverse Tens Digit: Forward and reverse prohibition (Applicable to all command channels, excluding jog) 0: Both Forward or Reverse are permitted 1: Reverse running is prohibited (When reverse running is applied, the machine will be stopped according to the stop mode) 2: Prohibition of forward running (When forward running is applied, the machine will stop according to the stop mode). Hundreds digit: Running direction choose reverse (Only valid for keyboard and communication channel) 0: Invalid 1: Valid Thousands digit: Terminal multi-step speed Acceleration/Deceleration time control 0: Corresponds to acceleration and deceleration 1 to 15 1: Determined by F01.17, F01.18	1	0x1010
F08.18	Function selection of input terminal X1	0: Control terminal is idle	1	0
F08.19	Function selection of input terminal X2	22: External device fault input	1	22
F09.00	Open collector output terminal Y1 output setting	1: Inverter running (RUN)	1	1
F09.04	RLY1 output setting	22: Inverter fault	1	22
F02.00	Start operation mode	0: Start from start frequency	1	0
F02.11	Stop mode	0: Deceleration stop	1	0
F03.00	V / F curve setting	1: Decreasing torque curve 1 (Power of 2.0)	1	1

Appendix D Application Macros

F19.01	Failure self-recovery times	0 ~ 10 (0 means no automatic reset function)	1	5
F19.02	Failure self-recovery interval	0.5~50.0s	0.1s	30.0s
F11.01	Given channel selection	0: Number given	1	0
F12.01	Target pressure setting	0.000 ~ Remote pressure gauge range	0.001 Mpa	0.200Mpa
F11.02	Feedback channel selection	1: AI2 analog input	1	1
F12.06	Remote pressure gauge range	0.001~9.999Mpa	0.001 Mpa	1.000Mpa
F12.02	Sleep frequency threshold	0.00Hz~Upper limit frequency	0.01Hz	30.00Hz
F12.03	Wake pressure threshold	0.000~Remote pressure gauge range	0.001 Mpa	0.150Mpa
F12.04	Sleep delay time	0.0~6000.0s	0.1s	5.0s
F12.05	Wakeup delay time	0.0~6000.0s	0.1s	5.0s
F12.11	Wake mode selection	0: Wake up according to the pressure defined by F12.03	1	0
F00.05	C-04 display parameter selection when running	36: Constant pressure water supply given pressure (0.001Mpa)	1	36
F00.06	C-05 display parameter selection when running	37: Constant pressure water supply feedback pressure (0.001Mpa)	1	37
F00.11	C-04 display parameter selection during stop	36: Constant pressure water supply given pressure (0.001Mpa)	1	36
F00.12	C-05 display parameter selection when stop	37: Constant pressure water supply feedback pressure (0.001Mpa)	1	37

D.3.4 Wiring diagram for fan application macro

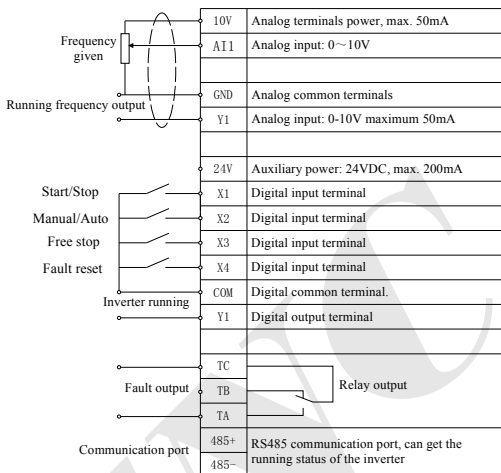

Parameter table corresponding to fan application macro.

F09.49 = 4: Fan application. After one-button setting, the parameters are shown in the following table:

Functions: Including manual/automatic switching function, speed tracking start, instantaneous stop non-stop, common failure retry function.

Manual: F01.01 sets the running frequency, keyboard control starts and stops; when automatic: AI1 voltage given frequency, terminal controls start and stop.

Function code	Function code name	Function code parameter description	Unit	Factory default
F01.15	Run command channel selection	1: Terminal running command control	1	1
F01.00	Main frequency input channel selection	1: AI1 analog setting	1	1
F01.01	Digital setting of main frequency	0.00Hz~Upper limit frequency	0.01Hz	35.00Hz
F01.17	Acceleration time 1	1~60000 (Acceleration time refers to the time required to accelerate from zero frequency to the upper limit frequency)	1	25.0
F01.18	Deceleration time 1	1 ~ 60000 (Deceleration time refers to the	1	30.0

Appendix D Application Macros

		time required to decelerate from the upper limit frequency to zero frequency)		
F01.11	Upper limit frequency	Lower limit frequency ~ 600.00Hz	0.01Hz	50.00Hz
F01.12	Lower limit frequency	0.00Hz ~ upper limit frequency	0.01Hz	0.00Hz
F01.16	Setting of running direction	Units digit: Keyboard command forward and reverse setting (Only valid for jog) 0: Forward 1: Reverse Tens Digit: Forward and reverse prohibition (Applicable to all command channels, excluding jog) 0: Both Forward or Reverse are permitted 1: Reverse running is prohibited (When reverse running is applied, the machine will be stopped according to the stop mode) 2: Prohibition of forward running (When forward running is applied, the machine will stop according to the stop mode). Hundreds digit: Running direction choose reverse (Only valid for keyboard and communication channel) 0: Invalid 1: Valid Thousands digit: Terminal multi-step speed Acceleration/Deceleration time control 0: Corresponds to acceleration and deceleration 1 to 15 1: Determined by F01.17, F01.18	1	0X1010
F08.18	Function selection of input terminal X1	1: Forward running FWD terminal	1	1
F08.19	Function selection of input terminal X2	49: Command switch to the panel	1	49
F08.20	Function selection of input terminal X3	25: Free stop input	1	25
F09.00	Open collector output terminal Y1 output setting	1: Inverter running (RUN)	1	1
F02.00	Start operation mode	2: Speed tracking start	1	2
F02.11	Stop mode	1: Free stop	1	1
F03.00	V/F curve setting	1: Decreasing torque curve 1 (power of 2.0)	1	1
F19.01	Failure self-recovery times	0 ~ 10 (0 means no automatic reset function)	1	5
F19.02	Failure self-recovery interval	0.5~50.0s	0.1s	30.0s

**Note**

- (1) When the AI2 current signal is selected as the reference/feedback, the AI2 switch on the control board is set to the current position to correctly receive the current signal.
- (2) When it is convenient to debug, except for the fan application macro, the factory command source is keyboard control. After debugging, please change to the required command source.
- (3) Industry application macros cannot guarantee the application needs of all users. Therefore, after selecting application macros, you may need to fine-tune related parameters

Appendix E Braking unit and braking resistance

E.1 Braking unit and braking resistance

The motor's electric potential energy will charge inverter's capacitance up reversely if speed of the motor descends too quickly or load of the motor wobbles too quickly while the inverter is running, which will increase the voltage upon power modules suddenly and is easy to make the inverter damaged. The inverter will control it according to load size and performance. You only need to connect external braking resistance to realize timely energy discharge when the braking function is needed. To connect external resistance is a kind of energy consumption braking mode, as all the energy is consumed by the braking resistance.

ENA100-2S0004B~ENA100-2S0022B, ENA100-4T0007H/0015LB ~ ENA100-4T0220H/0300LB have built-in brake unit as standard, ENA100-4T0300H/0370L ~ ENA100-4T1600H/1850L can be equipped with external brake unit.

When braking function needed, please connect external braking resistance according to below table.

Configuration table of braking unit and braking resistor configuration as well as circumscribed braking resistor

Model	Built-in brake unit	Built-in brake resistance	Add Braking resistor	Quantity	Power of braking resistor (50% braking rate)	Power of braking resistor (10% braking rate)
ENA100-2S0004B	Built-in	No	$\geq 150\Omega$	1PCS	$\geq 1KW$	$\geq 200W$
ENA100-2S0007B	Built-in	No	$\geq 100\Omega$	1PCS	$\geq 1.5KW$	$\geq 250W$
ENA100-2S0015B	Built-in	No	$\geq 70\Omega$	1PCS	$\geq 2KW$	$\geq 400W$
ENA100-2S0022B	Built-in	No	$\geq 50\Omega$	1PCS	$\geq 3KW$	$\geq 600W$
ENA100-4T0007H/0015LB	Built-in	No	$\geq 300\Omega$	1PCS	$\geq 1KW$	$\geq 250W$
ENA100-4T0015H/0022LB	Built-in	No	$\geq 300\Omega$	1PCS	$\geq 1KW$	$\geq 250W$
ENA100-4T0022H/0037LB	Built-in	No	$\geq 300\Omega$	1PCS	$\geq 1KW$	$\geq 250W$
ENA100-4T0037H/0055LB	Built-in	No	$\geq 125\Omega$	1PCS	$\geq 2KW$	$\geq 400W$
ENA100-4T0055H/0075LB	Built-in	No	$\geq 80\Omega$	1PCS	$\geq 3.8KW$	$\geq 750W$
ENA100-4T0075H/0110LB	Built-in	No	$\geq 80\Omega$	1PCS	$\geq 3.8KW$	$\geq 750W$
ENA100-4T0110H/0150LB	Built-in	No	$\geq 50\Omega$	1PCS	$\geq 5KW$	$\geq 1KW$
ENA100-4T0150H/0185LB	Built-in	No	$\geq 40\Omega$	1PCS	$\geq 7.5KW$	$\geq 1.5KW$
ENA100-4T0185H/0220LB	Built-in	No	$\geq 27\Omega$	1PCS	$\geq 9KW$	$\geq 1.8KW$
ENA100-4T0220H/0300LB	Built-in	No	$\geq 22\Omega$	1PCS	$\geq 11KW$	$\geq 2.2KW$



ENC Shenzhen Encom Electric Technologies CO., LTD.

Address: Floor 6, Building 2 West, Pingshan Minqi Science & Technology Park, Taoyuan Str., Nanshan District, Shenzhen, China

Website: www.encvfd.com

E-mail: encvfd@encvfd.com

encvfd@enc.net.cn

Tel: +86-755-26984485

Fax: +86-755-26985120